

DISCOVERY CLEAN WATER ALLIANCE

Engineering Report for the Phase 5A Project—Columbia River Outfall and Effluent Pipeline

Phase 5 Expansion Program



An Alliance Capital Project delivered by Clark Regional Wastewater District as Administrative Lead for the Discovery Clean Water Alliance



Prepared for

Washington State Department of Ecology

March 2018

ch2m.SM

2020 SW Fourth Avenue, 3rd Floor
Portland, Oregon 97201

Contents

Section	Page
Acronyms and Abbreviations	ix
Executive Summary	ES-1
Introduction	ES-1
Site Characteristics.....	ES-2
Future Conditions	ES-3
Flow Characteristics	ES-3
Wastewater Treatment and Effluent Characteristics	ES-3
Water Quality Standards and Design Dilutions	ES-3
Alternatives Analysis.....	ES-3
Recommended Alternative	ES-5
Permitting, Schedule, and Financial Considerations.....	ES-8
Compliance with Applicable Regulatory Requirements	ES-8
Project Implementation Schedule	ES-8
Cost Estimate	ES-9
Project Funding.....	ES-10
1 Introduction	1-1
1.1 Discovery Clean Water Alliance	1-1
1.2 Owner and Authorized Representative	1-3
1.3 Project Description and Location.....	1-3
1.4 Project Need	1-5
1.5 Project Purpose.....	1-5
1.6 Project Benefits.....	1-6
2 Site Characteristics	2-1
2.1 Background	2-1
2.2 Data Sources and Data Collections	2-1
2.2.1 Data Sources Listing.....	2-2
2.2.2 Columbia River Water Sampling and Analyses	2-3
2.3 Effluent Pipeline Route Characteristics	2-4
2.4 Columbia River Site Characteristics (River Mile 96).....	2-6
2.4.1 Columbia River Flow and Stage	2-7
2.4.2 Current Velocities and Tidal Influences at Columbia River Mile 96.....	2-13
2.4.3 Current Transport Characteristics	2-17
2.4.4 Water Quality Sampling at Columbia River Mile 96	2-20
2.4.5 River Bathymetry, Geomorphology, and Bedforms	2-23
2.4.6 Sediments Evaluation	2-25
2.4.7 Geotechnical Investigation	2-26
3 Future Conditions	3-1
3.1 Flow Characteristics	3-1
3.2 Wastewater Treatment and Effluent Characteristics	3-2
3.2.1 Wastewater Treatment	3-2
3.2.2 Effluent Chemical Characteristics	3-2
3.3 Water Quality Standards and Design Dilutions	3-2
3.3.1 303(d) Listing and Total Maximum Daily Loads.....	3-2

Section	Page
3.3.2	3-4
4	4-1
4.1	4-1
4.1.1	4-1
4.1.2	4-1
4.1.3	4-2
4.1.4	4-4
4.1.5	4-8
4.1.6	4-9
4.1.7	4-9
4.1.8	4-10
4.1.9	4-10
4.1.10	4-13
4.1.11	4-15
4.2	4-16
4.2.1	4-16
4.2.2	4-17
4.2.3	4-17
4.2.4	4-18
4.3	4-19
4.3.1	4-19
4.3.2	4-21
4.3.3	4-25
4.3.4	4-26
4.3.5	4-27
4.3.6	4-28
4.4	4-28
4.4.1	4-28
4.4.2	4-32
4.4.3	4-45
4.5	4-53
4.5.1	4-53
4.5.2	4-53
4.5.3	4-54
4.6	4-56
4.7	4-57
5	5-1
5.1	5-1
5.1.1	5-1
5.1.2	5-3
5.1.3	5-3
5.2	5-4
5.3	5-5
5.4	5-10
5.4.1	5-10
5.4.2	5-10

Section	Page
5.4.3	Salmon Creek Crossing..... 5-12
5.4.4	Lake River Crossing 5-13
5.4.5	Farmland Crossing 5-13
5.4.6	Wetland Crossings 5-13
5.4.7	Round Lake Conservation Bank Crossing..... 5-14
5.4.8	Outfall Construction in the Columbia River 5-14
5.4.9	Navigation Marker 5-15
5.4.10	Removal of Existing Outfall and Effluent Pipe near the Columbia River 5-15
5.4.11	Access and Staging..... 5-16
5.5	Effluent Pump Station Improvements and Phasing..... 5-17
5.5.1	Phase 5 Pump Station Improvements 5-17
5.5.2	Pump Station Control System 5-17
5.5.3	Constructability Sequencing and Provisions..... 5-17
5.6	Design Criteria Summary 5-17
5.7	30 Percent Design Drawings 5-18
5.8	O&M and Staffing 5-18
6	Permitting, Schedule, and Financial Considerations 6-1
7	References..... 7-1

Appendixes

A	Engineering Report Requirement Checklist (Ecology's Guidance)
B	Current Meter Data for Columbia River (on CD)
C	Columbia River Water Quality Measurements (on CD)
D	Columbia River Bedform and Shoreline Technical Memorandums
E	Sediment Evaluation Report for Columbia River RM 96 (on CD)
F	Geotechnical Data Reports (on CD)
G	SCTP Effluent Chemistry and RPA Sheets
H	Trenchless Crossing TM
I	Outfall Dilution Model Runs (on CD)
J	Effluent Pump Station
K	Cost Estimate

Tables

ES-1	Critical Phase 5A Project Drivers..... ES-2
ES-2	Summary of Design Criteria for the Phase 5A Project ES-7
ES-3	Summary of Total Phase 5A Project Cost..... ES-10
2-1	Minimum, Mean, and Maximum Monthly Stage at Vancouver, Washington, Water Years 1973 through 2003..... 2-11
2-2	Minimum, Mean, and Maximum Daily Stage at Vancouver, Washington, Water Years 1973 through 2003..... 2-12
2-3	Measured Current Speeds and Directions, Depths, and Temperatures at Columbia River Mile 96, August 26 to September 25, 2015..... 2-14

	Page
2-4 Summary of Background Columbia River Analytical Chemistry Results for Four Dry Season Sampling Events in 2015.....	2-22
3-1 Projected Peak Hourly Effluent Flows.....	3-1
3-2 Salmon Creek Treatment Plant Current, Projected Stages, and Projected Buildout Effluent Flow Statistics Used in Design Modeling.....	3-1
3-3 Evaluation of SCTP Discharge Compliance with Existing Washington Ammonia Criteria and with EPA 2013 Ammonia Water Quality Criteria and Definition of Target Design Dilutions for the SCTP Discharge to the Columbia River	3-5
3-4 Evaluation of Dilution Requirements for Water Quality Compliance for the Salmon Creek Treatment Plant Outfall 001 Discharge to the Columbia River	3-7
4-1 Allowable Pipe Materials by Location Along the Pipeline Route.....	4-9
4-2 List of Non-Cost Evaluation Criteria and Goals	4-15
4-3 Pipeline Diameter Alternatives Comparison.....	4-19
4-4 Velocities for Various Pipe Diameters by Phase and Material Type.....	4-20
4-5 Anticipated Pipe Material and Labor Cost	4-21
4-6 List of Non-Cost Evaluation Criteria and Goals	4-25
4-7 FlowMaster Results for the Columbia River at the SCTP (RM 96) for Dry and Wet Season, Annual Average, and Field-Measured Discharge Conditions.....	4-33
4-8 Comparison of Dilution Factors Between Visual Plumes (UM3) and CORMIX 2 Models Under Worst-Case Effluent and Ambient Conditions at Buildout Effluent Flow Conditions.....	4-36
4-9 Model-Predicted Dilution Factors under Critical Dry Season, Wet Season, and Annual Average Discharge Conditions for the Salmon Creek Outfall Replacement—Existing (2010–2016) Effluent Flows	4-41
4-10 Model-Predicted Dilution Factors under Critical Dry Season, Wet Season, and Annual Average Discharge Conditions for the Salmon Creek Outfall Replacement—Projected 2025 Effluent Flows	4-42
4-11 Model-Predicted Dilution Factors under Critical Dry Season, Wet Season, and Annual Average Discharge Conditions for the Salmon Creek Outfall Replacement—Projected 2040 Effluent Flows	4-43
4-12 Model-Predicted Dilution Factors under Critical Dry Season, Wet Season, and Annual Average Discharge Conditions for the Salmon Creek Outfall Replacement—Projected Ultimate (Buildout) Effluent Flows	4-44
4-13 Model-Predicted Minimum Dilutions for Critical Conditions	4-45
4-14 Summary of Water Quality Compliance Evaluation	4-46
4-15 Flow Projections.....	4-54
4-16 Pump Station Phasing	4-54

	Page
5-1	Hydraulic Data for Proposed Pipeline Materials..... 5-6
5-2	Preliminary Pump Selection Data 5-8
5-3	Summary of Design Criteria for SCTP Effluent Pipeline and Outfall Project..... 5-17
6-1	Summary of Construction Cost Estimate for the Phase 5A Project—Columbia River Outfall and Effluent Pipeline 6-4
6-2	Summary of Total Phase 5A Project Cost..... 6-5

Figures

ES-1	Existing Effluent Pipeline and Phase 5A Project Locations ES-1
ES-2	Overall Phase 5A Project Schedule ES-9
1-1	Salmon Creek Treatment Plant Design Capacity versus Projected Demand for Influent Flow 1-2
1-2	Salmon Creek Treatment Plant Design Capacity versus Projected Demand for Influent Loading 1-2
1-3	Alliance Service Area and Regional Assets..... 1-4
1-4	Existing Effluent Pipeline and Phase 5A Project Locations 1-4
2-1	Overview of Salmon Creek Treatment Plant, Effluent Pipeline, and Outfall Location on the Columbia River at River Mile 96 2-1
2-2	Columbia River Water Quality Profile and Background Chemistry Sampling Stations and Existing and Potential Replacement Salmon Creek Treatment Plant Outfall Diffuser Sites on the Columbia River..... 2-4
2-3	Overview of Discharge Site on the Columbia River and Upstream and Downstream Tributaries 2-7
2-4	Plot of Columbia River Discharge Flows Recorded at the USGS Gage 14105700 in The Dalles (January 2010 to October 2017)..... 2-8
2-5	Columbia River Flow at RM 96 (Combined Upstream River Flows versus Bonneville Dam Outflow plus the Sandy and Willamette Rivers, August to October 2015 2-9
2-6	Columbia River Stage (Gage Height) Measured at Vancouver, Washington (February 1998 to September 2015) 2-11
2-7	Locations of Current Meter Arrays A and B Deployed August 26 to September 25, 2015, in the Columbia River near River Mile 96 2-13
2-8	Daily Mean Columbia River Discharge and Near-surface Current Speed near Columbia River RM 96, August 26 through September 25, 2015 2-15
2-9	Principal Component Plot of Near-Surface Currents at Current Meter Array A near RM 96, August 26 through September 25, 2015 2-16

	Page
2-10	Near-Surface Current Speed and Direction in the Columbia River near RM 96 at CM Array ‘A,’ August 26 through September 25, 2015 2-16
2-11	Probable Discharge Plume Trajectory Plot from Drogues Released at Potential Diffuser Site 1 (Array A) near Columbia River Mile 96 on September 23, 2015 2-18
2-12	View of Probable Discharge Plume Trajectory Plot from Drogues Released at Potential Diffuser Site 2 (Array B) near Columbia River RM 96 on October 14, 2015..... 2-19
2-13	Columbia River Bathymetric Survey 2-29
2-14	Lake River and Salmon Creek Single Beam Bathymetric Surveys 2-31
4-1	Overview of Columbia River Bathymetry Along Eastside of River Between RM 95.5 and RM 96.2 4-4
4-2	River Elevation versus Gravity Flow Capacity 4-5
4-3	Effluent Flow by Phase with Gravity flows at a Variety of River Elevations 4-6
4-4	System Curves, New 48-Inch-Diameter and Existing 30-Inch-Diameter Pipelines 4-7
4-5	Salmon Creek and BNSF Railroad Crossing Alternatives..... 4-24
4-6	Overview of Potential New SCTP Outfall Diffuser Sites on the Columbia River 4-29
4-7	Locations of Potential New SCTP Outfall Routes and Diffuser Sites on the Columbia River Near RM 96..... 4-30
4-8	Replacement SCTP Outfall Route and Diffuser Site on the Columbia River Near RM 96 4-30
4-9	Location of New SCTP Outfall Diffuser Site on the Columbia River Near RM 96 Relative to Designated Navigation Channel and Anchorage Areas 4-31
4-10	Effluent Pump Capacity by Phase and Year 4-56
5-1	Diffuser and Manifold Head Loss 5-6
5-2	System Curves for Existing 30-Inch-Diameter and New 48-Inch-Diameter Pipelines 5-7
5-3	One Pump Operating 5-8
5-4	Two Pumps Operating 5-9
5-5	Three Pumps Operating 5-10
6-1	Overall Phase 5A Project Schedule 6-3

Acronyms and Abbreviations

°C	degrees Celsius
7Q10	discharge at the 10-year recurrence interval taken from a frequency curve of annual or seasonal values of the lowest (or highest) mean discharge for 7 consecutive days (that is, the 7-day, 10-year low flow)
30Q5	lowest mean discharge for 30 consecutive days, with a recurrence interval of 5 years
µg/L	micrograms per liter
µS/cm	microSiemens per centimeter
AACE	Association for the Advancement of Cost Engineering
AAF	average annual flows
ADMM	average-day maximum month
Alliance	Discovery Clean Water Alliance
AWWA	American Water Works Association
AZB	acute zone boundary
BEP	best efficiency point
BNSF	Burlington Northern Santa Fe
BOD	biochemical oxygen demand
CCTV	closed-circuit television
CFR	Code of Federal Regulations
cfs	cubic feet per second
CWA	Clean Water Act
CM	current meter
cm/sec	centimeters per second
CML	cement mortar lined
CPU	Clark Public Utilities
CRD	Columbia River Datum
CWA	Clean Water Act
DNR	Washington Department of Natural Resources
DR	dimension ratio
Ecology	Washington State Department of Ecology
EFH	Essential Fish Habitat
EPA	U.S. Environmental Protection Agency
ESA	Endangered Species Act
ft/sec	feet per second

ACRONYMS AND ABBREVIATIONS

gpm	gallons per minute
GPS	global positioning system
HDD	horizontal directional drilling
HDPE	high-density polyethylene
lb/day	pounds per day
IPS	iron pipe size
mgd	million gallons per day
mg/L	milligrams per liter
mL	milliliters
msl	mean sea level
MTBM	microtunnel boring machine
MZB	mixing zone boundary
NAD83/91	North American Datum of 1983/91
NAVD88	National Geodetic Vertical Datum of 1988
NEPA	National Environmental Policy Act
NGVD29	National Geodetic Vertical Datum of 1929
NMFS	National Marine Fisheries Service
NOAA	National Oceanic and Atmospheric Administration
NPDES	National Pollutant Discharge Elimination System
NTU	nephelometric turbidity units
NWS	National Weather Service
O&M	operations and maintenance
OD	outside diameter
OHWE	ordinary high water elevation
PAHs	polycyclic aromatic hydrocarbons
PATON	private aid to navigation
PCBs	polychlorinated biphenyls
PDT	Pacific Daylight Time
PE	professional engineer
PHF	peak hourly flows
psi	pounds per square inch
PVC	polyvinyl chloride
QAPP	Quality Assurance Project Plan
RCW	Revised Code of Washington
RM	River Mile

RMZ	regulatory mixing zone
RPA	reasonable potential analysis
SCTP	Salmon Creek Treatment Plant
SDR	standard dimension ratio
SEPA	State Environmental Policy Act
SWCAA	Southwest Clean Air Agency
TMDL	total maximum daily load
TPH	total petroleum hydrocarbons
TSS	total suspended solids
USACE	U.S. Army Corps of Engineers
USCG	U.S. Coast Guard
USFWS	U.S. Fish and Wildlife Service
USGS	U.S. Geological Survey
VP	Visual Plumes
WAC	Washington Administrative Code
WDFW	Washington State Department of Fish and Wildlife
WET	Whole Effluent Toxicity
WSDOT	Washington State Department of Transportation
WSE	water surface elevation
WWRF	Westside Water Reclamation Facility
WWTP	wastewater treatment plant

Executive Summary

Introduction

The Phase 5A Project—Columbia River Outfall and Effluent Pipeline consists of a new 48-inch-diameter treated effluent transmission pipeline from the Salmon Creek Treatment Plant (SCTP) and improved effluent discharge system to the Columbia River, as shown in Figure ES-1. The existing 43-year-old, 30-inch-diameter effluent pipeline will remain in service (minus its outfall diffuser) as a contingency for performing maintenance on the new effluent pipeline. The second effluent pipeline will upgrade the existing transmission system by increasing system longevity and facilitating pipeline maintenance. Furthermore, the Phase 5A Project will replace the existing outfall diffuser with an improved diffuser that will comply with future water quality standards by ensuring adequate mixing and dilution of treated water discharged into the Columbia River.

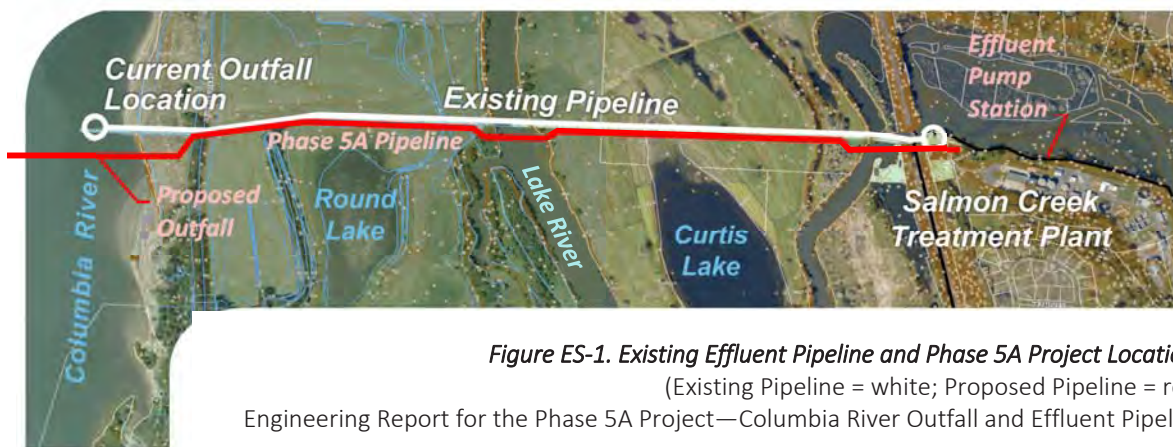


Figure ES-1. Existing Effluent Pipeline and Phase 5A Project Locations
(Existing Pipeline = white; Proposed Pipeline = red)

Engineering Report for the Phase 5A Project—Columbia River Outfall and Effluent Pipeline

The *Salmon Creek Wastewater Management System Wastewater Facilities Plan/General Sewer Plan Amendment* (2013 Facilities Plan) (CH2M, 2013) describes the need for the capital improvements of the Phase 5A Project, one of several SCTP expansion phases planned through 2028. Expansion will be needed to meet future demand (Clark County, 2016) and enable eventual decommissioning of Ridgefield’s aging wastewater treatment plant and outfall into Lake River. The Phase 5A Project will size the new transmission pipeline and outfall diffuser with capacity to process 2028 influent flows (i.e., up to 30.70 million gallons per day [mgd] [average-day maximum month (ADMM)]) and will size effluent pump station capacity to process up to 35.8 mgd (ADMM). However, the Phase 5A Project will not increase the SCTP’s overall flow capacity because the overall flow capacity is constrained by the capacities of the existing aeration basins and secondary clarifiers.

The purpose of the Phase 5A Project is to address the following five critical project drivers identified by the Alliance:

- Provide long-term capacity to support planned growth within the service area.
- Ensure adequate mixing and dilution of treated wastewater discharged into the Columbia River.
- Provide reliable wastewater treatment service at an affordable rate.
- Address riverbed and shoreline stability maintenance issues.
- Enable future decommissioning of the Ridgefield Treatment Plant.

How the proposed project will address the Alliance’s five critical drivers is summarized in Table ES-1. The proposed Phase 5A Project will be designed, constructed, operated, and maintained to meet the effluent limitations and other wastewater discharge permit terms and conditions necessary to protect public health and the environment.

The Discovery Clean Water Alliance (Alliance) prepared this Engineering Report in conformance with the Washington Administrative Code 173-240-060 and the Washington State Department of Ecology's *Criteria for Sewage Works Design* (2008).

Table ES-1. Critical Phase 5A Project Drivers

Critical Project Driver	Project Approach
<p>Provide long-term capacity to support planned growth within the service area. This includes increased hydraulic capacity of the SCTP, consistent with the Clark County <i>20 Year Comprehensive Growth Management Plan 2015–2035</i> (Clark County, 2016)</p>	<p>The Alliance's Phase 5A Project builds on decades of planning to ensure the agency can meet the region's long-term wastewater treatment needs and continue safeguarding public health, environmental quality, and the service area's economic future. The transmission system upgrade will support planned growth in the community. The new conveyance pipeline will ensure continued reliable service at a stable, affordable rate by planning and constructing for the long term and avoiding the increased cost of isolated improvements.</p>
<p>Ensure adequate mixing and dilution of treated wastewater discharged into the Columbia River. This includes diffuser improvements to achieve water quality standards for the long term.</p>	<p>By ensuring adequate mixing and dilution of discharged treated effluent, the project will improve water quality in the Columbia River. The new diffuser will be relocated farther offshore to deeper water to improve dilution performance, nearshore fish passage, and protection of beneficial uses of the Columbia River.</p>
<p>Provide reliable wastewater treatment service at an affordable rate through coordinated project planning, especially with other planned improvements in the area.</p>	<p>By planning and constructing an effluent pipeline that will satisfy all future phased flow increases—as part of the Phase 5 expansion—the Alliance will make efficient use of limited funds and avoid repeated environmental impacts.</p>
<p>Address riverbed and shoreline stability maintenance issues at the Columbia River discharge site. Sand waves threaten to bury the existing outfall diffuser; and the retreating shoreline, which is composed of sandy dredged material, threatens to expose the pipeline unless armored.</p>	<p>The project will increase pipe reliability and reduce ongoing maintenance. Maintenance at the discharge location will be reduced by extending the height of diffuser ports above prevalent sand wave heights and by laying the approach pipeline deeper and below the erodible shoreline. The new pipeline will allow potential future channel migration of Lake River and Salmon Creek, and be set 150 feet from the Burlington Northern Santa Fe Railway Bridge over Salmon Creek. If pipeline or diffuser maintenance is needed, the new effluent pipeline will be equipped with improved maintenance access ports. Reduced maintenance will reduce periodic expenditures and better assure compliance with the National Pollutant Discharge Elimination System permit, as will retaining the existing effluent pipeline for maintenance use. No additional staffing will be required because of this project.</p>
<p>Enable future decommissioning of the Ridgefield Treatment Plant and its outfall into Lake River (after additional collection system projects are in place).</p>	<p>The project will provide sufficient effluent conveyance capacity to allow future decommissioning of the Ridgefield Treatment Plant; the Alliance will curtail that plant's operations and maintenance costs, and eliminate the plant's discharges to Lake River.</p>

Site Characteristics

The effluent pipeline route includes rural agricultural properties, wetlands, water course crossings, and a railroad crossing. The route is agricultural and undeveloped with relatively few built obstructions or conflicts.

The SCTP outfall discharge at River Mile 96 is within the lower Columbia River, approximately 5 miles downstream of the Willamette River confluence and approximately 8 miles upstream of the Lewis River confluence. The site is subjected to diurnal tide-induced elevation changes throughout the year, and, during low to moderate river flows in the Columbia and Willamette Rivers, the river flow is subject to flood tide-induced reversals. Tidal ranges can be as large as approximately 3 feet under lower river flows and large flood tidal exchange periods.

Project-specific land and hydrographic surveys, geotechnical investigations, as well as cultural and environmental investigations have been completed to supplement existing information along the effluent pipeline route.

The site selection and design development for the replacement outfall and diffuser in the Columbia River required assessment of physical site conditions at the potential replacement outfall diffuser sites and surrounding river area. The design development has also required input and analyses of ambient river and effluent chemistry to define design dilutions for compliance with state water quality standards. This Engineering Report includes analyses that apply collected river and effluent chemistry data to assess discharge compliance with water quality standards (WAC 173-201A-200 to 260) and with the state's antidegradation policy (WAC 173-201A-300 to 410).

The Columbia River flows, river stages, current velocities, tidal influences, and current transport characteristics were reviewed and evaluated. Water quality sampling was performed and background river water chemistry reviewed. Columbia River bathymetry, geomorphology, bedforms, sediments, and shoreline stability were evaluated as they pertain to the proposed project.

Future Conditions

Flow Characteristics

The projected buildout peak hourly flow of 72 mgd was used to design the effluent pipeline. The existing and projected effluent flows used in the diffuser design modeling include a dry weather maximum day flow at buildout of 37.3 mgd and a wet weather maximum day flow at buildout of 50.9 mgd.

Wastewater Treatment and Effluent Characteristics

No changes are proposed to the SCTP wastewater process, and no changes to effluent characteristics are proposed as a result of the improvements proposed under this Engineering Report.

Water Quality Standards and Design Dilutions

Key elements of Washington's water quality standards (WAC 173-201A) impact the design of outfall improvements for the SCTP. These were reviewed for the development of the design criteria. Key elements of the water quality standards that can impact the design and permitting include existing water quality impairment (that is, 303(d) listing and total maximum daily loads [TMDLs]), compliance with water quality chemical criteria and temperature standards, effluent toxicity to aquatic organisms, and antidegradation review.

A detailed evaluation of dilution requirements for the SCTP effluent was developed to define dilutions required to meet Washington's water quality standards. This evaluation was developed to identify the effluent constituents that require the greatest dilution to meet the water quality standards, and these represent the target design dilutions or minimum design dilutions for the outfall improvements and diffuser.

Alternatives Analysis

Several effluent pipeline alignments, outfall configurations, and pump station upgrade alternatives were developed and evaluated for the project. They were within the range of effluent pipeline and outfall alternatives that were proposed and evaluated in the *Salmon Creek Wastewater Treatment Plant Expansion Program Final Environmental Impact Statement* (CH2M, 1995). The recommended alternative was developed from the available alignments and feasible construction techniques for each reach of the project, taking into account landowner and easement restrictions, environmental impacts, archaeological and wetland resources, practicable and permissible construction methods, utility

conflicts, site access, anticipated shoreline erosion and river scour, geotechnical conditions, cost implications, and implementation risk.

The existing 30-inch-diameter gravity/force main discharge line is constructed of reinforced concrete pipe. The new effluent discharge piping alternatives considered three different diameter configurations: a single 48-inch-diameter pipe, twin 36-inch-diameter pipes, and phasing the installation of new pipelines using the existing 30-inch-diameter plus one new 36-inch-diameter pipeline (with the intention of installing an additional 36-inch-diameter pipeline in the future). Based on the advantages and disadvantages of each option, a single 48-inch-diameter pipe was selected as the preferred alternative. Flow velocities for various pipe diameters, phases, and material types confirmed that a 48-inch-diameter pipe is the best alternative for the project. The reliability would be high and the cost evaluations show that this would be the least costly alternative. Moreover, this alternative would have the smallest footprint.

The evaluation was conducted to meet the project purpose and need as practicable, as follows:

- The selected effluent pipeline alignment, outfall diffuser configuration, and construction methods will minimize the construction footprint and adverse natural resources effects. It will also increase pipe reliability, minimize future maintenance activities and risks of damage or exposure of the pipeline, especially at waterway crossings and in the Columbia River. Maintenance at the discharge location will be reduced by extending the height of diffuser ports above prevalent sand wave heights and by laying the approach pipeline deeper and below the erodible shoreline.
- The pipeline diameter and material selection provides long-term capacity to support planned growth within the service area. The new effluent pipeline will allow for future increased effluent flow capacity for sewer customers served by the Alliance.
- The new Columbia River discharge facility (outfall diffuser) will ensure adequate mixing and dilution of treated wastewater discharged into the Columbia River and the diffuser improvements will achieve water quality standards over the foreseeable future. It will meet the effluent limitations and other wastewater discharge permit terms and conditions necessary to protect public health and the environment and will comply with Washington water quality standards (WAC 173-201A-200 to -260) and with the state's antidegradation policy (WAC 173-201A-300 to -410).
- The cost of the recommended alternative ensures that the Alliance can continue to provide reliable wastewater treatment service at an affordable rate.
- The design of the effluent pipe at the Columbia River shoreline will account for riverbed and shoreline stability and erosion-caused exposure through removal of the existing outfall diffuser and placement of the pipeline below the general scour prism with a concrete revetment mat for protection.
- Eventually, the new pipeline will allow the Ridgefield Treatment Plant and its existing outfall into Lake River to be decommissioned after additional collection system projects are in place, by providing sufficient capacity to convey treated Ridgefield flows.

The Alliance's Phase 5A Project—Columbia River Outfall and Effluent Pipeline ensures that the agency can meet the region's long-term wastewater treatment needs and continue safeguarding public health, environmental quality, and the service area's economic future. The transmission system upgrade from the SCTP will support planned growth in the community. By ensuring adequate mixing and dilution of discharged treated effluent, the project will improve water quality in the Columbia River. And by planning and constructing an effluent pipeline that will satisfy future phased flow increases—as part of the Phase 5 expansion—the Alliance will make efficient use of limited funds and avoid repeated environmental impacts.

Recommended Alternative

The recommended alternative consists of a new effluent pipeline, new outfall diffuser, and effluent pump station improvements, as represented in the 30 percent design drawings that were developed for the Phase 5A Project—Columbia River Outfall and Effluent Pipeline.

Effluent Pipeline

The proposed 48-inch-diameter effluent pipe will begin at the discharge pump station at the western end of the SCTP and extend approximately 6,100 feet (continuing in the westerly direction) to the edge of NW Lower River Road, which parallels the Columbia River. A structure at this location will transition the new effluent pipeline to the planned outfall pipe extending into the Columbia River. Installation of the new pipeline will include construction in open fields that are pasture or farmed for hay production and crossing under Burlington Northern Santa Fe (BNSF) railroad, Salmon Creek, Lake River, and NW Lower River Road. Curtis Lake and Round Lake may be peripherally impacted because both are shallow bodies of water have fluctuating water levels, filling during winter rains, receding during the summer.

Based on the cost comparison and history of use, steel pipe and HDPE pipe were selected as the preferred materials. Both materials have a long history of use and the estimated costs are considered reasonable. Allowing bids on alternate materials should provide for competitive bids and result in lower project costs.

Outfall Diffuser

The buried 144-foot-long outfall diffuser pipe section will be a horizontal pipe with a burial depth of 6 to 8 feet over the pipe crown. The 48-inch-diameter outfall pipe will terminate with a steel blind flange. The horizontal outfall diffuser pipe will be pile-supported along its length with 11 pile supports at 15-foot spacing along the 160-foot diffuser pipe. Paired 12-inch steel piles will connect into a precast concrete pile cap with a saddle for the 48-inch-diameter pipe and two stainless steel pipe straps will bolt to the concrete pile cap.

The recommended outfall diffuser will consist of 10 concrete-coated steel riser pipes that extend from a flange 2-feet above the diffuser pipe crown to a flange situated above the riverbed. Riser pipes may include intermediate flanges to avoid riser pipe lengths of greater than 8 feet. The first 9 riser pipes from shore will consist of 16-inch inside-diameter (ID) pipe sections that are concrete coated. The last offshore riser will consist of a 36-inch access manhole with a 2-foot length of 16-inch riser flanged to the top. All 10 risers will be fitted with mitered 16-inch ID steel pipe elbows that terminate with a flange and 16-inch elastomeric check valve port (manufacturer to be defined in specifications). The horizontal and vertical angles of the riser elbows and attached elastomeric check valve ports will be 45° downriver (north) and 20° above horizontal, respectively. The outfall diffuser will have all ports located at water depth of 42.6 feet (National Geodetic Vertical Datum of 1929 [NGVD29]) at low river flow conditions.

Removal of the Existing Outfall and Retention of the Existing Effluent Pipeline

Much of the 7,462-foot-long existing 30-inch-diameter effluent pipeline will remain in place. It is anticipated that the existing effluent pipeline from the SCTP to the last manhole between Lower River Road and the Columbia River will serve as a back-up pipeline and will be used if maintenance is required on the new effluent pipeline. A future use for the pipeline could also include serving as effluent reuse. A connection will be installed to tie in the existing and new outfall pipes between Lower River Road and the Columbia River. A butterfly valve installed on each pipeline ahead of this junction and at the SCTP connection will allow for use and inspection of one or the other pipelines if necessary.

The existing diffuser and outfall pipe will no longer be used to dilute flows to the river. Approximately 870 feet of pipe will be removed from the end of the diffuser back to the tie-in with the existing

pipeline. An in-depth evaluation of shoreline erosion confirmed that the existing and future outfall pipe are at risk of exposure from continued shoreline erosion and should be removed. The supporting piles, riprap, and navigation marker for the existing outfall pipe will also be removed during construction.

Pipe Materials and Project Elements

Both steel and high-density polyethylene (HDPE) are considered as acceptable pipe materials with certain limitations within specific portions of the alignment. HDPE pipe and steel pipe with appropriate linings and coatings are both corrosion resistant materials.

The connection to the SCTP includes elbows, wyes, tees, access manways, and flanged valves. Due to the number of fittings, steel pipe is recommended for the connection. The connection piping and valves allow flow to be directed to either the existing effluent pipe or the new effluent pipe. The new effluent pipe will continue west across open land owned by the Alliance. Pipe material in this section will be steel. One air valve vault will be located in this section.

The crossing of the BNSF railroad tracks and embankment will be through a steel casing pipe. At the west end of the casing, the grade of the effluent pipe will increase to cross under Salmon Creek. The Salmon Creek crossing will be made with steel pipe.

On the west side of Salmon Creek, an air valve/access manway is proposed at the high point. The pipe west of the Salmon Creek crossing to the Lake River crossing will be either steel or HDPE pipe. The effluent pipeline will cross under two existing utilities in this section: a fiber optic cable and a petroleum line. An access manway is proposed near the low point in the profile.

An air valve/manway is proposed at the high point just before the crossing of Lake River. The pipe for the crossing of Lake River will be steel. On the west side of Lake River, an access manway is proposed for access and to allow dewatering of the low spot in the profile under Lake River.

On the west side of Lake River, an access manway is proposed approximately half-way between Lake River and Lower River Road. This pipe in this section will be either steel or HDPE. Just west of Lower River Road, a junction connecting to the existing outfall is proposed. This junction will include isolation valves, access manways, and air valves. The existing effluent pipe leading to the existing outfall will be abandoned at this point.

West of Lower River Road, the effluent pipe will continue to the outfall portion of the project in the Columbia River. An air valve/access manway is proposed at the point where the pipe profile dips down sharply to the river. The top of the air relief valve will be above the 500-year flood elevation for the Columbia River. Due to the gradual movement of the steep bank away from the river, a ball joint is proposed at the base of the steep slope. A concrete revetment mat is proposed in the slope to help protect the pipe in the event that the steep slope continues to migrate to the east away from the river.

The effluent pipe will continue along a relatively flat area with an elevation of about 3 feet. This section of pipe will be below the ordinary high-water elevation, but slightly above the 7Q10 elevation of approximately 2.1 feet. The profile of the effluent pipe will then drop rapidly with a slope of about 25 percent down to the elevation of the horizontal outfall pipe with ten diffusers. Ball joints are proposed at both the top and base of this slope. The outfall pipe will be supported on piles, but the effluent pipe will be supported by the native materials, in this area, primarily sand. The ball joints will allow a considerable degree of pipe flexibility if the native materials either settle or are partially moved by the river flow.

Construction Methods

Construction methods were evaluated by contacting various general, marine and trenchless contractors to discuss construction feasibility, listening to their recommendations for tunneling options, and discussing open cut feasibility and required areas available for staging and access. Construction methods

were evaluated regarding the plant site, railroad undercrossing, Salmon Creek crossing, Lake River crossing, farmland crossing, wetland crossings, Round Lake Conservation Bank crossing, outfall construction in the Columbia River, navigation marker, removal of existing outfall near the Columbia River, and construction access and staging.

Effluent Pump Station Improvements and Phasing

The four existing pump slots will be replaced with new vertical line shaft pumps. The initial pump replacements will be four equally sized pumps with a firm capacity of 43.8 mgd and a 75 HP motor. This will give the effluent pump station enough capacity through 2013 Facilities Plan Phases 5 (peak hourly flow of 36 mgd) and 6 (peak hourly flow of 43 mgd). The effluent pump station will be controlled by monitoring the liquid level in the effluent channel. The pumps will be replaced one at a time to keep the pump station in service at all times. Pump replacement may be constrained to dry weather season to ensure that gravity effluent flow is possible.

Design Criteria Summary

Table ES-2 summarizes the design criteria for the Phase 5A Project—Columbia River Outfall and Effluent Pipeline.

Table ES-2. Summary of Design Criteria for the Phase 5A Project

Engineering Report for the Phase 5A Project—Columbia River Outfall and Effluent Pipeline

Design Element	Design Criteria
Effluent Design Flows	Peak hour effluent flow at buildout (72 mgd) Dry weather maximum day flow at buildout (37.3 mgd) Wet weather maximum day flow at buildout (50.9 mgd) SCTP effluent pump station improvements (43.8 mgd)
Design Vertical and Horizontal Datum	Horizontal datum is Washington State plane coordinates (South Zone, NAD83 (2011)) Vertical datum (feet) is NGVD29
Pipeline Route Criteria	Parallel alignment to existing SCTP pipeline Separation and Offset Requirements Use of existing negotiated easements and utilities avoidance Access to pipeline for construction and operations and maintenance Soil, groundwater, wetlands and cultural resource conditions on route Construction methods feasibility
Pipeline Design Criteria	Pipe materials for minimum 50-year life span Pipe support requirements using native soils and imported backfill Pipe protection on river shoreline use minimum burial depth to crown (10 feet) and buried concrete revetment mat Combination air/vacuum release valves at high points along pipeline Pipeline inspection manholes for internal pipe inspections
Outfall and Diffuser Site and Design	Hydraulic capacity, head loss limits, and discharge velocity Dilution requirements to meet water quality standards with safety factor Structural stability of river outfall and diffuser pipe Design to accommodate river bedform dynamics and bank erosion Navigation marker (lighted) to protect diffuser in river
Pipeline and Pump Hydraulics	100-year flood river elevation (25.6 feet, NGVD29) Four effluent pumps (allow one pump out of service for reliability and redundancy) Effluent flows > 36.2 mgd must be pumped regardless of river elevation

Table ES-2. Summary of Design Criteria for the Phase 5A Project*Engineering Report for the Phase 5A Project—Columbia River Outfall and Effluent Pipeline*

Design Element	Design Criteria
Safety Factors	Steel pipe to AWWA standards and Manual 11 guidelines for steel (a minimum of 2 for internal pressure) HDPE pipe to AWWA standards and Manual 55 guidelines HDPE pipe Outfall pipe minimum burial depth to crown in river (8 feet) Diffuser dilution factors at buildout effluent flow and at critical river discharge conditions of 100 percent to meet acute and chronic aquatic life criteria
Connection to SCTP	Minimize removal of existing 30-inch effluent pipeline Minimize head loss Allow for effluent flow conveyance through existing or new pipeline Thrust restraints against unbalanced hydrostatic forces Minimize duration of flow shut-downs to make new pipeline connections

AWWA = American Water Works Association

Permitting, Schedule, and Financial Considerations

Compliance with Applicable Regulatory Requirements

For the proposed Phase 5A Project, the Alliance will obtain the applicable permits and approvals. Also, the project will need to comply, minimally, with these regulatory requirements, although no specific permit or approval is required:

- Tribal consultations
- Migratory Bird Treaty Act
- Bald and Golden Eagle Protection Act
- Marine Mammal Protection Act

The Phase 5A Project will not rely on federal funding, so the project will not have a National Environmental Policy Act documentation requirement, other than that required for federal permitting.

As SEPA lead agency, the Alliance performed the environmental review, prepared the SEPA checklist, determined the potential for environmental impact, and distributed the public notice in cooperation with Clark County. The Alliance issued a SEPA Mitigated Determination of Non-Significance as all unavoidable environmental impacts will be insubstantial and/or temporary through minimization or mitigation.

Project Implementation Schedule

The overall Phase 5A Project spans a multi-year period inclusive of planning and preliminary design; permitting and easement acquisition; and final design, bidding, and construction. The project schedule is summarized in Figure ES-2.

The project implementation schedule allows for flexibility and contingencies for obtaining regulatory permits and approvals before construction. It is expected that federal and state permits and approvals can be obtained within a 12-month timeframe, and local permits in 3 to 6 months.

Phase	2015	2016	2017	2018	2019	2020	2021	2022
Planning and Preliminary Design								
Permitting and Easements								
Final Design, Bidding, and Construction								

Figure ES-2. Overall Phase 5A Project Schedule
Engineering Report for the Phase 5A Project—Columbia River Outfall and Effluent Pipeline

The constraints and timelines for construction will be driven by permit terms and conditions, concerns for regulatory compliance, and operability considerations. The major scheduling constraints are as follows:

- In-Water Work—Washington State Department of Fish and Wildlife (WDFW) recommended in-water work periods (WDFW, 2017), which are as follows:
 - Columbia River: August 1 through March 31
 - Lake River: June 1 through October 31
 - Salmon Creek: July 15 through August 15

It is uncertain whether the project can be constructed in one construction season, or will extend over two construction seasons. The work duration will be determined by permitting constraints, weather/water stage, construction method, and the equipment and personnel brought by the contractor. The in-water work period for Salmon Creek is particularly short for constructing cofferdams, temporary work platform, and the effluent pipeline in a single season. It may be possible to negotiate modifications to the recommended work windows because the sites are physically close yet the windows vary greatly.

- Navigability—Vessel navigation on the Columbia River, Lake River, and Salmon Creek needs to remain open (passable) year-round, unless the U.S. Coast Guard approves short duration closures.
- Flood Hazard Areas—The FEMA-designated floodways on the Columbia River cannot rise during 100-year flood (from temporary or permanent installation of fills or structures). (Lake River and Salmon Creek do not have designated floodways in the project area.) The highest maximum monthly stage of the Columbia River occurs during January and February, and the period of high maximum monthly stages occurs from November through June (USACE, 2014).
- Wet Season and Groundwater—Saturated surface soil and elevated groundwater tables are expected to be greatest/highest during January and February, and elevated from November through June. Construction during July through October will facilitate access, earthwork, and trench dewatering.
- Migratory Birds—Preferred timeframe for vegetation clearing is outside the migratory bird nesting season, which generally ranges from mid-March to mid-August.

Cost Estimate

A preliminary estimate of the total project costs for the proposed project based on the Engineering Report recommendations was prepared and is presented in Table ES-3. The estimate assumes costs for all elements expected to be part of the final design.

The cost estimate is a Class 3 cost estimate as defined by the Association for the Advancement of Cost Engineering (AACE) with a level of accuracy of +30 percent/-20 percent. The estimate is based on assumptions about cost factors and draws from various cost resources, such as R.S. Means (2016) data, CH2M historical data, vendor quotes where available, Washington State Department of Transportation/Oregon Department of Transportation realized prices, and estimator judgement. The final costs of the project will depend on the actual labor and material costs, competitive market conditions, final project scope, implementation schedule, and other variable factors.

Table ES-3. Summary of Total Phase 5A Project Cost

Engineering Report for the Phase 5A Project—Columbia River Outfall and Effluent Pipeline

Item	Cost Estimate
<i>Delivery</i>	
Engineering and Project Management	\$3,400,000
Permitting	\$1,800,000
Construction Management	\$1,800,000
Total Delivery	\$7,000,000
<i>Construction</i>	
Effluent Pipeline and Outfall	\$11,912,965
Effluent Pump Station Improvements	\$1,017,073
Contingency (25%)	\$3,232,510
Taxes (8.4%)	\$1,357,654
Total Construction	\$17,520,202
Total Project Cost	\$24,520,202

Project Funding

In 2014, the Alliance adopted a comprehensive Capital Plan that brings the partners' facility assets, including the SCTP and discharge facilities, under Alliance ownership. Planning and design costs for the Columbia River Outfall and Effluent Pipeline Project are covered in the Capital Plan.

In total, the project is anticipated to cost \$23–25 million. As the initial phases of the project progress, the full scope and budget will be better known.

Introduction

1.1 Discovery Clean Water Alliance

The Discovery Clean Water Alliance (Alliance) legally formed on January 4, 2013, representing the culmination of several years of evaluation to determine the optimum long-term framework for delivery of regional wastewater transmission and treatment services to the urban growth areas in the central portion of Clark County, Washington. The Alliance serves four Member agencies: City of Battle Ground (Battle Ground), Clark County (County), Clark Regional Wastewater District (District), and the City of Ridgefield (Ridgefield). The Members jointly own and jointly manage regional wastewater assets under Alliance ownership through an interlocal framework established under the State of Washington Joint Municipal Utility Services Act (Revised Code of Washington [RCW] 39.106).

The Alliance is responsible for managing the capacity of its assets. The Salmon Creek Treatment Plant (SCTP) is the Alliance's primary regional asset. The SCTP is an advanced secondary treatment facility with ultraviolet light disinfection, operating under National Pollutant Discharge Elimination System (NPDES) Waste Discharge Permit No. WA0023639 issued by Ecology and Air Discharge Permit 07-2726 issued by the Southwest Clean Air Agency (SWCAA). The Washington State Department of Ecology (Ecology) requires the Alliance to submit a plan and schedule to maintain adequate capacity in its treatment facilities when one of the following two conditions is met:

- Actual flow or actual waste load reaches 85 percent of the rated capacity of the facility for 3 consecutive months, or
- Projected flow or projected waste load will reach the design capacity of the facility within 5 years

SCTP capacity has been assessed relative to these criteria for both flow and waste load. The *Salmon Creek Wastewater Management System Wastewater Facilities Plan/General Sewer Plan Amendment* (2013 Facilities Plan) (CH2M, 2013) describes needed capital improvements in SCTP Expansion Program phases planned through 2028. Ecology approved the 2013 Facilities Plan in a letter dated September 4, 2013. Flow and load trends are depicted in Figures 1-1 and 1-2, respectively.

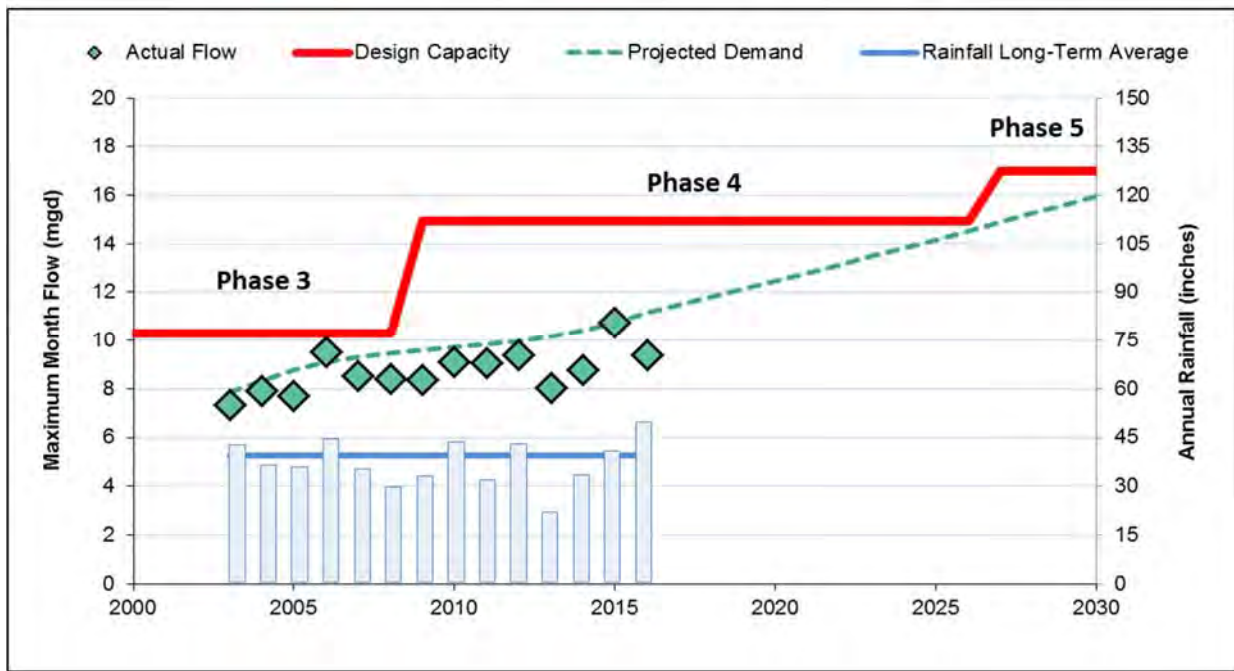


Figure 1-1. Salmon Creek Treatment Plant Design Capacity versus Projected Demand for Influent Flow
Engineering Report for the Phase 5A Project—Columbia River Outfall and Effluent Pipeline

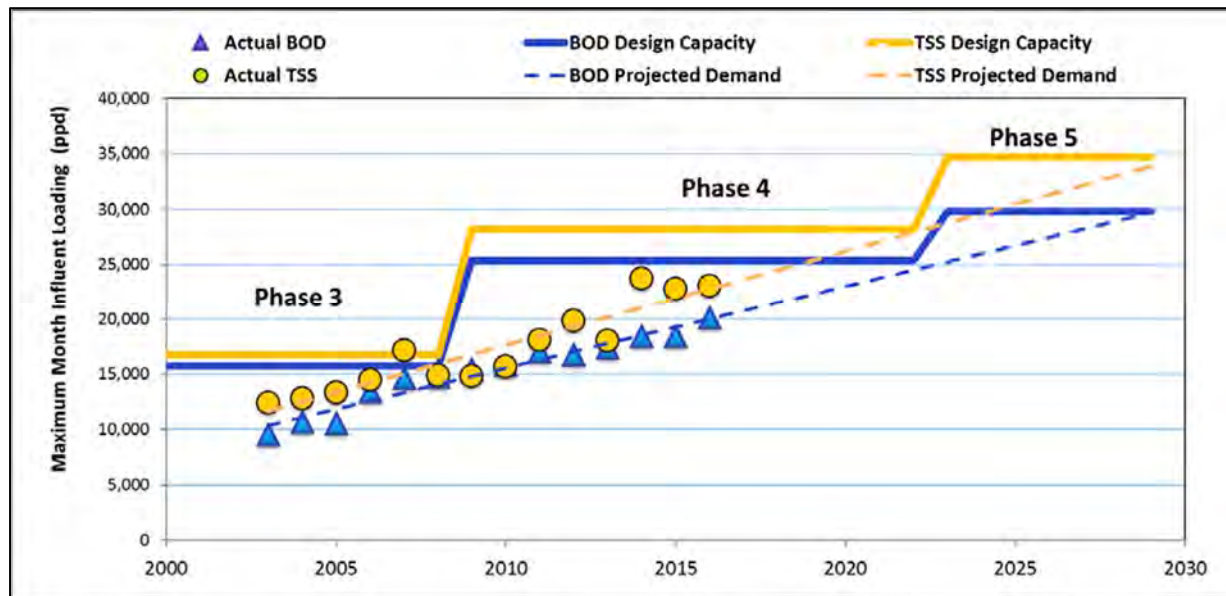


Figure 1-2. Salmon Creek Treatment Plant Design Capacity versus Projected Demand for Influent Loading
Engineering Report for the Phase 5A Project—Columbia River Outfall and Effluent Pipeline
 (BOD = 5-day biochemical oxygen demand; ppd = pounds per day; TSS = total suspended solids)

Expansion Program Phase 3 and Phase 4 projects have been completed previously. The Phase 5 Expansion Program consists of two separate elements:

- *Phase 5A Project—Columbia River Outfall and Effluent Pipeline* constructs a new effluent pipeline and outfall to address long-term system hydraulic capacity and diffuser performance. This project has independent utility, and is required to support future expansion phases of SCTP.
- *Phase 5B Project—Salmon Creek Treatment Plant Improvements* addresses facility loading and treatment capacity with an updated process and hydraulic analysis, and facility improvements. This

project is required to address shorter-term capacity needs related to flow and organic loading to the facility.

While both occur under the overall Phase 5 Expansion Program, the Phase 5A Project is distinctly separate from Phase 5B Project. The Phase 5A Project consists of a new 48-inch-diameter treated effluent transmission pipeline from the SCTP and improved effluent discharge system to the Columbia River. The existing 43-year-old, 30-inch-diameter effluent pipeline will remain in service (minus its outfall diffuser) as a contingency for performing maintenance on the new effluent pipeline. The second effluent pipeline will upgrade the existing transmission system by increasing system longevity and facilitating pipeline maintenance. Furthermore, the Phase 5A Project will replace the existing outfall diffuser with an improved diffuser that will comply with future water quality standards by dilution of treated water discharged into the Columbia River.

Phased expansion of SCTP is needed to meet projected demand (Clark County, 2016) and enable eventual decommissioning of Ridgefield's aging wastewater treatment plant and outfall into Lake River. The Alliance is planning for the treatment demand through 2066, when Phase 9 of the Expansion Program will treat 72 million gallons per day [mgd] peak-hour flow. Therefore, the Phase 5A Project will size the new transmission pipeline and outfall diffuser with capacity to process 2066 influent flows (i.e., up to 72 mgd).

The existing effluent pump station is rated to meet the 28.3 mgd peak-hour flow. The existing vertical, mixed flow, open line shaft effluent pumping system consists of two 14-inch pumps and two 18-inch pumps. The Phase 5A Project will replace all four pumps and size effluent pump station capacity to process up to 43.8 mgd peak-hour flow (24.3 mgd ADMM). However, the Phase 5A Project will not increase the SCTP's overall flow capacity because none of the other unit processes will be altered as part of Phase 5A.

This Engineering Report examines engineering and administrative aspects of the Alliance's Phase 5A Project. It is the Engineering Report required by WAC 173-240-060 and has been developed and organized to address that code and Ecology's *Criteria for Sewage Works Design* (2008), as itemized in the compliance checklist and cross reference provided in Appendix A.

1.2 Owner and Authorized Representative

The Owner of the SCTP is the Alliance,. The District is responsible for engineering and capital planning, as well as the overall financial and administrative functions of the Alliance. The Owner's authorized representative for this facility is Dale Lough. His contact information is as follows:

Dale W. Lough, PE,
 Capital Program Manager
 Clark Regional Wastewater District (Administrative Lead for Discovery Clean Water Alliance)
 8000 NE 52nd Court
 Vancouver, WA 98668-8979
 (360) 993-8856
www.crwwd.com
Dlough@crwwd.com

1.3 Project Location

Figure 1-3 shows the Alliance's service area and regional assets. SCTP serves 41,000 homes and businesses in the service area. The SCTP, Alliance Regional Asset 7, is located at 15100 Northwest McCann Road in Vancouver, Washington. Clark County Public Works operates and maintains the plant, which has 14 full-time staff, including managers, maintenance technicians, certified operators, and a laboratory analyst.

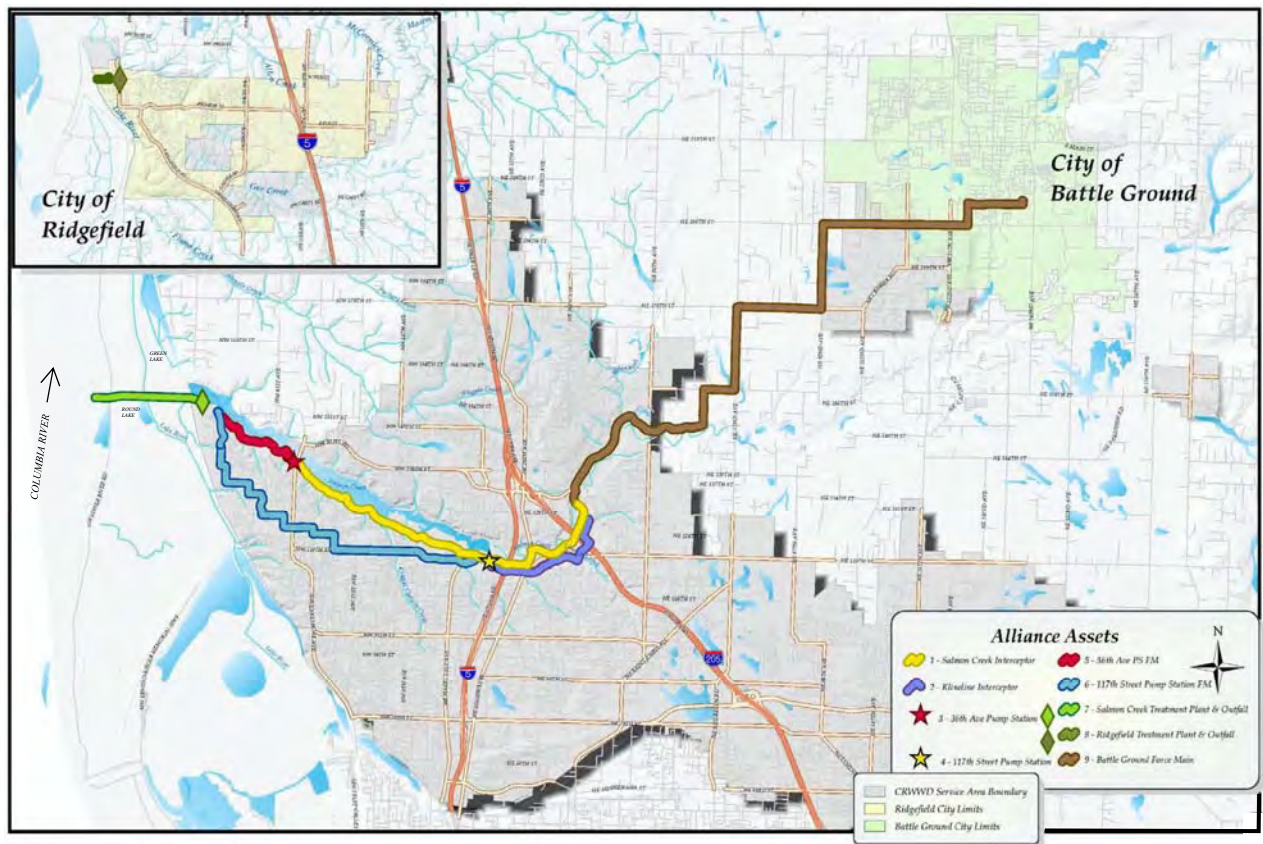
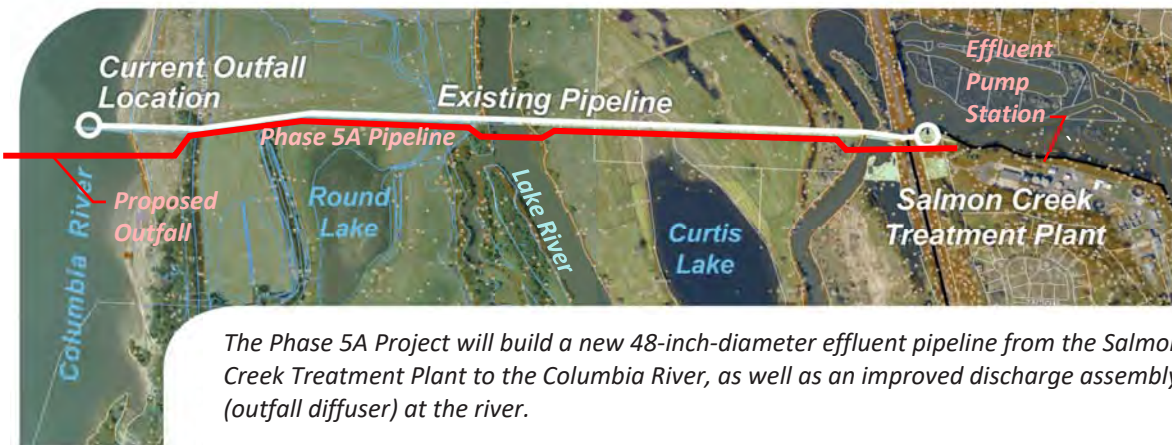


Figure 1-3. Alliance Service Area and Regional Assets
 Engineering Report for the Phase 5A Project—Columbia River Outfall and Effluent Pipeline
 (Service Area = shaded colors; SCTP and Outfall = green)

Treated effluent is discharged toward the west via a 30-inch-diameter, 1.3-mile-long pipeline constructed in 1974. Figure 1-4 shows the location of the existing 30-inch-diameter effluent pipeline in relation to the Phase 5A Project pipeline. The existing effluent pipeline terminates at a multi-port diffuser in the Columbia River near River Mile (RM) 96. The discharge location is latitude 46° 43' 58" N, longitude 122° 45' 23" W.



The Phase 5A Project will build a new 48-inch-diameter effluent pipeline from the Salmon Creek Treatment Plant to the Columbia River, as well as an improved discharge assembly (outfall diffuser) at the river.

Figure 1-4 Existing Effluent Pipeline and Phase 5A Project Locations
 Engineering Report for the Phase 5A Project—Columbia River Outfall and Effluent Pipeline
 (Existing Pipeline = white; Proposed Pipeline = red)

The pipeline is in Township 3 North, Range 1 East, Section 19, and Township 3 North, Range 1 West, Section 24; within Clark County Parcels 183508-000, 183493-000, 986029-218, 183058-000, 191067-000, 191176-000, and 191177-000; and crosses property owned by the Burlington Northern Santa Fe Railway Company (BNSF) and State of Washington (Washington State Department of Transportation [WSDOT] and Washington Department of Natural Resources [DNR]). The project site lies in U.S. Geological Survey (USGS) Hydrologic Unit Codes 170800030103 (Lower Salmon Creek), 170800030104 (Lake River-Frontal Columbia River), and 170800030200 (Hayden Island-Columbia River); and Ecology’s Water Resource Inventory Area 28.

1.4 Project Need

The project need is to implement the Phase 5 Expansion Program concepts established in the 2013 Facilities Plan (CH2M, 2013). The need for wastewater treatment facility expansion is established in RCW 90.48, 90.52, and 90.54 to prevent and control pollution of state waters. The 2013 Facilities Plan is a phased approach for ensuring the SCTP remains viable and supports the requirements of the Alliance Member agencies. Its projections indicate that increased wastewater transmission capacity and an improved river discharge facility will be needed at least through 2028.

The Alliance has identified the following five critical Phase 5A Project drivers:

1. Provide long-term capacity to support planned growth within the service area. This includes increased hydraulic capacity of the SCTP, consistent with the Clark County *20 Year Comprehensive Growth Management Plan 2015-2035* (Clark County, 2016).
2. Ensure adequate mixing and dilution of treated wastewater discharged into the Columbia River. This includes diffuser improvements to achieve water quality standards for the long term.
3. Provide reliable wastewater treatment service at an affordable rate through coordinated project planning, especially with other planned improvements in the area.
4. Address riverbed and shoreline stability maintenance issues at the Columbia River discharge site. Sand waves threaten to bury the existing outfall diffuser; and the retreating shoreline, which is comprised of sandy dredged material, threatens to expose the pipeline unless armored.
5. Enable future decommissioning of the Ridgefield Treatment Plant and its outfall into Lake River (after additional collection system projects are in place).

1.5 Project Purpose

The purpose of the Phase 5A Project is to construct a new, larger effluent pipeline to increase wastewater transmission capacity from SCTP, and to install an improved Columbia River discharge facility (outfall diffuser) for more predictable achievement of future water quality standards. The existing 30-inch-diameter effluent pipeline (minus its outfall diffuser) will remain in service as a standby facility for maintenance activities on the new effluent pipeline.

The proposed Phase 5A Project will be designed, constructed, operated, and maintained to meet the effluent limitations and other wastewater discharge permit terms and conditions necessary to protect public health and the environment.

The design development for the new outfall and diffuser in the Columbia River requires assessment of physical site conditions at the outfall diffuser site and surrounding river area. The design requires input and analyses of ambient river and effluent chemistry to define design dilutions for compliance with state water quality standards. The new outfall diffuser discharge design will comply with Washington water quality standards (WAC 173-201A-200 to -260) and with the state’s anti-degradation policy (WAC 173-201A-300 to -410).

The new outfall and effluent pipeline must achieve the following objectives:

1. Provide future increased effluent flow capacity for sewer customers served by the Alliance.
2. Demonstrate through hydraulic modeling that the outfall diffuser design provides mixing and dilutions to achieve water quality standards for its design life, and prevents and controls pollution to U.S. and state waters.
3. Provide sufficient capacity to convey flows from the eventual fully built SCTP for forward compatibility. Integrate harmoniously with existing and future property uses, including coordination with the planned Round Lake Conservation Bank to avoid construction conflicts.
4. Design effluent pipeline and outfall diffuser to minimize the construction footprint and adverse natural resources effects, and to minimize future maintenance activities and risks of damage or exposure, especially at waterway crossings and in the Columbia River.
5. Enable future decommissioning of the Ridgefield Treatment Plant and its outfall into Lake River by providing sufficient capacity to convey Ridgefield flows.

1.6 Project Benefits

The Alliance’s Phase 5A Project builds on decades of planning to ensure the agency can meet the region’s long-term wastewater treatment needs and continue safeguarding public health, environmental quality, and the service area’s economic future. The transmission system upgrade from the SCTP will support planned growth in the community. The new conveyance pipeline will be sized appropriately to ensure continued reliable service at a stable, affordable rate by planning and constructing for the long term and avoiding the increased cost and environmental disturbance in sensitive areas of incremental improvements.

By providing adequate mixing and dilution of discharged treated effluent, the project will improve water quality in the Columbia River. The new diffuser will be located farther offshore to deeper water to improve dilution performance, nearshore fish passage, and protection of beneficial uses of the Columbia River.

By planning and constructing an effluent pipeline that will satisfy all future phased flow increases—as part of the Phase 5 expansion—the Alliance will make efficient use of public funds and avoid repeated environmental impacts.

The project will increase pipe reliability and reduce ongoing maintenance. Maintenance at the discharge location will be reduced by extending the height of diffuser ports above prevalent sand wave heights and by laying the approach pipeline deeper and below the erodible shoreline. The new pipeline will allow potential future channel migration of Lake River and Salmon Creek, and be set 150 feet south of the BNSF railroad bridge over Salmon Creek. If pipeline or diffuser maintenance is needed, the new effluent pipeline will be equipped with improved maintenance access ports. Reduced maintenance will reduce periodic expenditures and better assure compliance with the NPDES permit, as will retaining the existing effluent pipeline for maintenance use. No additional staffing or training will be required because of this project.

Providing sufficient effluent conveyance capacity to allow future decommissioning of the aging Ridgefield Treatment Plant, as a future capital project, the Alliance will decommission that plant’s operations and maintenance (O&M) costs, and eliminate the plant’s discharges to Lake River.

Site Characteristics

2.1 Background

The SCTP, effluent pipeline, and outfall to the Columbia River were designed and installed in the early 1970s. The effluent pipeline and outfall need to be replaced to remain viable and to support the requirements of the Alliance Member agencies. The SCTP is an advanced secondary treatment facility with ultraviolet light disinfection. Treated effluent is discharged to the Columbia River through a multi-port outfall diffuser located near RM 96. Figure 2-1 illustrates the location of the SCTP, the approximate effluent pipeline route, and the outfall diffuser site on the Columbia River.



Figure 2-1. Overview of Salmon Creek Treatment Plant, Effluent Pipeline, and Outfall Location on the Columbia River at River Mile 96

Source: CH2M modified from Google Earth, 2017
 Engineering Report for the Phase 5A Project—Columbia River Outfall and Effluent Pipeline

2.2 Data Sources and Data Collections

The effluent pipeline route includes rural agricultural properties, wetlands, water course crossings, and a railroad crossing. The route is agricultural and undeveloped with relatively few built obstructions or conflicts. Project-specific land and hydrographic surveys, geotechnical investigations, as well as cultural and environmental investigations have been completed to supplement existing information along the effluent pipeline route.

The site selection and design development for the replacement outfall and diffuser in the Columbia River required assessment of physical site conditions at the potential replacement outfall diffuser sites and surrounding river area. The design development has also required input and analyses of ambient river and effluent chemistry to define design dilutions for compliance with state water quality standards. This Engineering Report includes analyses that apply collected river and effluent chemistry data to

assess discharge compliance with water quality standards (WAC 173-201A-200 to 260) and with the state’s anti-degradation policy (WAC 173-201A-300 to 410).

2.2.1 Data Sources Listing

Data sources developed for this project include the following:

- River flow records from the USGS gages on the Columbia River at The Dalles plus gages on the Willamette, Sandy, Hood, Klickitat, and White Salmon tributary rivers were compiled to develop river flow statistical analyses for critical river flow conditions (for use in dilution modeling).
- Site-specific current velocities and direction measurements during critical low-flow conditions in August to September 2015 at the potential diffuser site in the Columbia River (for use in dilution modeling).
- Plume transport measurements from two potential diffuser sites under low river flow and tidal-affected conditions, using drogues deployed at model-predicted plume trapping depths to represent the potential plume transport routes downstream.
- Ambient receiving water column data collections during August, September, and October 2015 to represent receiving water quality conditions under critical low river flow conditions for dilution modeling and NPDES permit renewal (refer to Section 2.2.2 Columbia River Water Sampling and Analyses).
- Background Columbia River water chemistry data collections during August, September, and October 2015 to represent receiving water chemistry under dry season river conditions for use in the reasonable potential analysis and NPDES permit renewal.
- Bathymetric Surveys: Multi-beam bathymetric surveys were conducted by Solmar Hydro in October 2012 on the Columbia River between RM 95.75 and 96.5, in July 2015 in Lake River and Salmon Creek along a wide replacement outfall route and covering the Columbia River between RM 95.5 and 96.5. Additional multi-beam bathymetric surveys were conducted in March 2017 in Salmon Creek along the replacement outfall route and in the Columbia River between RM 95.75 and 96.0.
- Water surface elevations (WSE) recorded near RM 106 (Vancouver) by USGS gage and statistically analyzed by the U.S. Army Corps of Engineers (USACE) for the period of 1973 to 2003.
- Hydraulic data for the Columbia River through online resources including USGS and NOAA. USGS flow gaging stations upstream of Vancouver at The Dalles (USGS 14105700) and downstream at Beaver Army Terminal (USGS 14246900). NOAA water level gauges at Vancouver (NOAA Station 9440083) and St. Helens (NOAA Station 9439201).
- NOAA Tides & Currents predicted tidal elevations data for the Columbia River at Knapp Landing (RM 95) for the field data collections period in 2015 and to evaluate long-term historical tidal elevations.
- Surface sediment sample collections in the vicinity of the existing SCTP outfall diffuser, chemical analyses, and reporting (2016) to document sediment conditions at the existing discharge to support the DNR easement and Section 404 permitting with USACE.
- NOAA Hydrographic Survey Database (Survey 11858 conducted in 2008–2009) and local bathymetry surveys conducted by Solmar Hydro in 2012 and 2015 were used along with river hydraulic data to develop the *Columbia River Bedform Analysis for Salmon Creek WWTP – Columbia River Outfall and Effluent Pipeline Project Technical Memorandum* (CH2M, July 2016).

- Geotechnical borings at sites along the land and river outfall route to a depth below the maximum pipeline trench excavation depth (completed in 2016 and 2017) for use in the final design of the outfall and effluent pipeline replacement.
- Salmon Creek Treatment Plant Discharge Monitoring Reports (2011 to 2017), including flow and temperature records, and effluent chemistry data (2011 to 2017).
- SCTP wastewater flow and load projections through buildout developed in the 2013 Facilities Plan (CH2M, 2013).
- Existing geological reports and structural/hydraulic analyses of the Lower Columbia River Pile Dikes near RM 95 (AECOM and USACE, 2011).
- 1974 outfall design and construction documents for the existing SCTP outfall in the Columbia River at the project site.
- Technical reports and referenced documents for development of the proposed project’s SEPA Checklist (Alliance, 2018) and Mitigated Determination of Non Significance. (See Section 7—References.)

2.2.2 Columbia River Water Sampling and Analyses

Columbia River sampling and chemical analyses were developed for the design and permitting of the replacement outfall and diffuser. Before data collection began, the *Quality Assurance Project Plan for Water Quality Sampling of the Columbia River* (CH2M, 2015) was prepared for the Alliance and submitted to Ecology on July 17, 2015, for review and approval. Following comments from Ecology, the Quality Assurance Project Plan (QAPP) was revised and resubmitted to Ecology on July 31, 2015. The QAPP defines the project objectives, approach, procedures, quality control/quality assurance requirements, data review, and data reporting for the water quality sampling of the Columbia River.

The sampling process design defined in the QAPP includes three elements: (1) collecting background Columbia River water samples monthly at a site upstream of the SCTP outfall (during ebb tide) from July through October 2015, (2) conducting water quality measurements in vertical water column profiles at five Columbia River sampling sites during ebb and flood tides from July through October 2015, and (3) collecting continuous in situ water quality measurements at mid-water depth using an instrument on an anchored cable array located at one Columbia River sampling site during 4 separate days in early August through October 2015. In addition, month-long and continuous ambient current measurements were conducted at two potential replacement outfall diffuser sites under low river flow conditions. Figure 2-2 illustrates the locations of the water column profile stations, continuous water quality monitoring station (WQ-2), background river sampling site, and the potential replacement outfall diffuser sites.



Figure 2-2. Columbia River Water Quality Profile and Background Chemistry Sampling Stations and Existing and Potential Replacement Salmon Creek Treatment Plant Outfall Diffuser Sites on the Columbia River

Source: CH2M modified from Google Earth, 2015

Engineering Report for the Phase 5A Project—Columbia River Outfall and Effluent Pipeline

2.3 Effluent Pipeline Route Characteristics

The proposed 48-inch-diameter effluent pipeline route will extend from the existing effluent pump station at the SCTP (Station 81+66 shown in PP-08) to the 10-foot by 12-foot junction box at the connection to the existing 30-inch-diameter outfall pipe (Station ~21+25 shown in PP-02). The 6,039-foot-long route will be about 22 to 25 feet south of and roughly parallel to the existing 30-inch-diameter effluent pipeline from SCTP, deviating at the railway and river crossings.

The environmental setting of the proposed effluent pipeline route is summarized for representative resource categories in the Phase 5A Project—Columbia River Outfall and Effluent Pipeline SEPA Checklist (Alliance, 2018). The SEPA Checklist is based on project-specific cultural and environmental investigations (AINW, 2017; BergerABAM, 2015; BergerABAM, 2017a).

The proposed pipeline route is in the jurisdiction of Clark County, in the northern half of Section 24, Township 3 North, Range 1 West and the northern half of Section 19, Township 3 North, Range 1 East of the Willamette Meridian. The route is subject to the *20 Year Comprehensive Growth Management Plan* (Clark County, 2016). The SCTP is zoned Public Facilities. The route then passes through properties zoned as Single-Family Residential or (mostly) Agriculture/Wildlife.

The pipeline will begin at the SCTP on land owned by the Alliance (Parcel 183508-000). Thereafter, it will lie in permanent or long-term easements (existing or to be acquired) across land owned by public and private parties, as does the existing pipeline. The pipeline route will cross a WSDOT right-of-way, a BNSF right-of-way, and three DNR waterways (Salmon Creek, Lake River, and Columbia River). The private properties that will be crossed are owned by BNSF Railway Company, Ashley Ridge North, LLC (Parcel 183493-000), Felida 26 Acres, LLC (Parcel 986029-218), Curtis Lake Ranch—Meyer (Parcels 183058-000, 191067-000, and 191176-000), and New Columbia Garden—Fazio (Parcel 191177-000). The New Columbia Garden Co. and RAA 2010 LLC of Battle Ground have proposed the Round Lake Conservation Bank Project on Parcel 191177-000; the project is undergoing natural resources and land use approvals.

The route has many advantages, including the following:

- Follows the corridor of the existing 30-inch-diameter effluent pipeline.
- Conforms to the preferred action of the *Salmon Creek Wastewater Treatment Plant Expansion Program Final Environmental Impact Statement* (CH2M, 1995)
- Runs the shortest length.
- Reduces pumping requirements.
- Crosses relatively few ownerships.
- Traverses a rural, agricultural/undeveloped site with relatively few built obstructions or operational conflicts/hazards.
- Avoids residences; the closest residence (Ashely Ridge) is over 700 feet away.
- Complies with the State Environmental Policy Act (SEPA), with environmental impacts determined as non-significant, after mitigation.

Impacts to regulated resources along the route will be avoided or minimized, as practicable. These resources include:

- Navigable waterways—Columbia River, Lake River, and Salmon Creek.
- Waters of the U.S. and State—Columbia River, Lake River, and Salmon Creek below the ordinary high-water elevation (OHWE). The OHWE of the Columbia River at RM 96 is 15.53 feet National Geodetic Vertical Datum of 1929 [NGVD29]) (USACE, 1973).
- Water Quality—Columbia River is on Ecology's 303(d) list for bacteria, temperature, and dissolved oxygen. Lake River is on Ecology's 303(d) list for temperature, bacteria, 2, 3, 7, 8-TCDD (dioxin), 4,4'-DDE, polychlorinated biphenyls (PCBs), and dieldrin. Salmon Creek is on Ecology's 303(d) list for dissolved oxygen.
- Archaeological resources eligible for listing in the National Register.
- Endangered Species Act-Listed Species/Critical Habitats—Listed plants are not known to occur, but golden paintbrush and water howellia may occur in the vicinity of the project area. Listed animal species and their critical habitats known to occur in the project area include Chinook salmon, chum salmon, coho salmon, sockeye salmon, steelhead, Pacific eulachon, and North American green sturgeon. Listed animals that may occur in the project vicinity are: streaked horned lark, yellow-billed cuckoo, and bull trout.
- Essential Fish Habitat (EFH)—Columbia River, Lake River, and Salmon Creek are EFH for Pacific salmon and groundfish.
- Marine Mammals—Marine mammals that occur in the Columbia River include: harbor seal, California sea lion, and Steller sea lion.

- Wetlands—Clark County Category II wetlands; actual number will be determined during final design.
- Clark County Wetland Buffers—110-feet wide for all Category II wetlands in low intensity land use.
- Clark County special flood hazard areas—floodways along the Columbia River and Salmon Creek, and 100-year floodplain west of the BNSF railroad.
- Shorelands—Columbia River, Lake River, and Salmon Creek are Type S waterbodies. Round Lake is a Type F (fish-bearing) waterbody.
- Clark County Habitat Conservation Areas—Riparian Priority Habitat, Priority Habitat (Aquatic Habitat, Salmon Creek Biodiversity Corridor), and Priority Species (California sea lion, and Steller sea lion, threatened and endangered salmon and steelhead, waterfowl concentrations, great blue heron, dusky Canada goose, and wood duck).
- Habitat Conservation Area Buffers—extend from the Columbia River and Lake River OHWEs to the edge of their 100-year floodplains, and 250 feet from the Salmon Creek OHWE.

2.4 Columbia River Site Characteristics (River Mile 96)

The SCTP outfall discharge at RM 96 is within the lower Columbia River, approximately 5 miles downstream of the Willamette River confluence and approximately 8 miles upstream of the Lewis River confluence. The site is subjected to diurnal tide-induced elevation changes throughout the year, and, during low to moderate river flows in the Columbia and Willamette Rivers, the river flow is subject to flood tide-induced reversals. Tidal ranges can be as large as approximately 3 feet under lower river flows and large flood tidal exchange periods. Figure 2-3 shows the project location on the Columbia River, nearby cities, and the major tributaries to the Columbia River within 8 miles of the site. Vancouver Lake drains to Lake River, which flows slowly on a path parallel to the Columbia River main stem, and enters the Columbia River approximately 0.75 mile upstream of the Lewis River confluence.



Figure 2-3. Overview of Discharge Site on the Columbia River and Upstream and Downstream Tributaries

Source: CH2M modified from Google Earth, 2015

Engineering Report for the Phase 5A Project—Columbia River Outfall and Effluent Pipeline

2.4.1 Columbia River Flow and Stage

2.4.1.1 Columbia River Flow

River flow (discharge) in the lower Columbia River varies according to the management of the numerous reservoirs within the river system, seasonal variations, and flood events. Analyses of wastewater dilution for discharges located in rivers are typically performed using hydrologically based low river flows. The low-flow receiving water conditions typically produce worst-case model predicted dilutions (highest concentrations) that result because of decreased ambient current velocities and water depths.

Discharge data were obtained from the USGS National Water Information System Web database for the Columbia River at The Dalles, Oregon (Gage 14105700), which is located at RM 188.9, approximately 93 miles upstream of the SCTP outfall. USACE provides provisional-only data from Bonneville Dam. Flows from Bonneville Dam were fairly consistent with flows from The Dalles gage station. However, flow data from Bonneville Dam are identified as un-citable unless reviewed and approved by the agency responsible for collection. Therefore, flows reported from Bonneville Dam during the study period (August to October 2015) were only used for comparative purposes, and the flows from The Dalles gage plus downstream tributary rivers were used as the measure of river flow for the study site.

Seasonal river flows in the Columbia River are illustrated in Figure 2-4 for discharge flows at The Dalles USGS gage during the period of 2010 through the fall of 2017. The river flows peak each year during the

spring snowmelt and runoff period (March through June), are elevated during the wet season (November through March), and they are lowest in the late summer to fall (August through October).

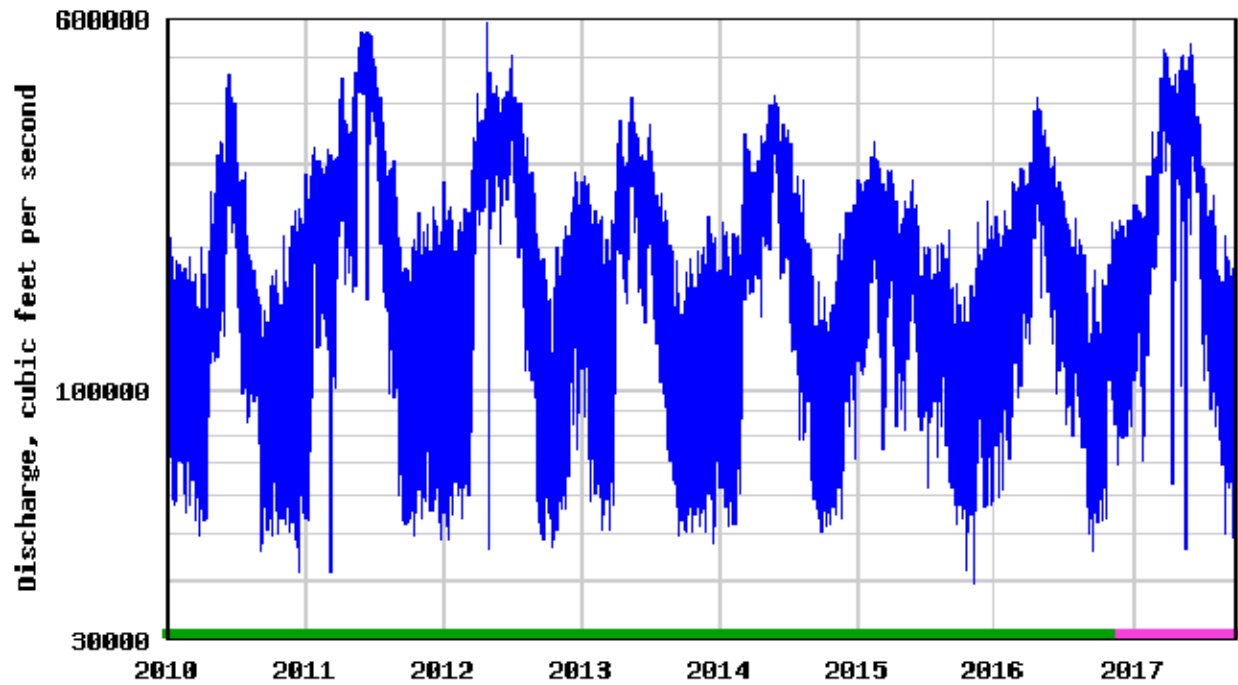


Figure 2-4. Plot of Columbia River Discharge Flows Recorded at the USGS Gage 14105700 in The Dalles (January 2010 to October 2017)

Source: USGS, 2017

Engineering Report for the Phase 5A Project—Columbia River Outfall and Effluent Pipeline

For comparison, the Columbia River flows recorded by the USACE at Bonneville Dam plus the Sandy and Willamette river flows are also plotted in Figure 2-5. During the 3-month low-flow study period, flows ranged from 80,000 to 160,000 cubic feet per second (cfs). Figure 2-5 displays the plot of the Columbia River flows at RM 96 during the 2015 field data collection period. The river flows at RM 96 are based on the combined recorded flows for the Columbia River at The Dalles, plus the Hood, Klickitat, White Salmon, Sandy, and Willamette rivers.

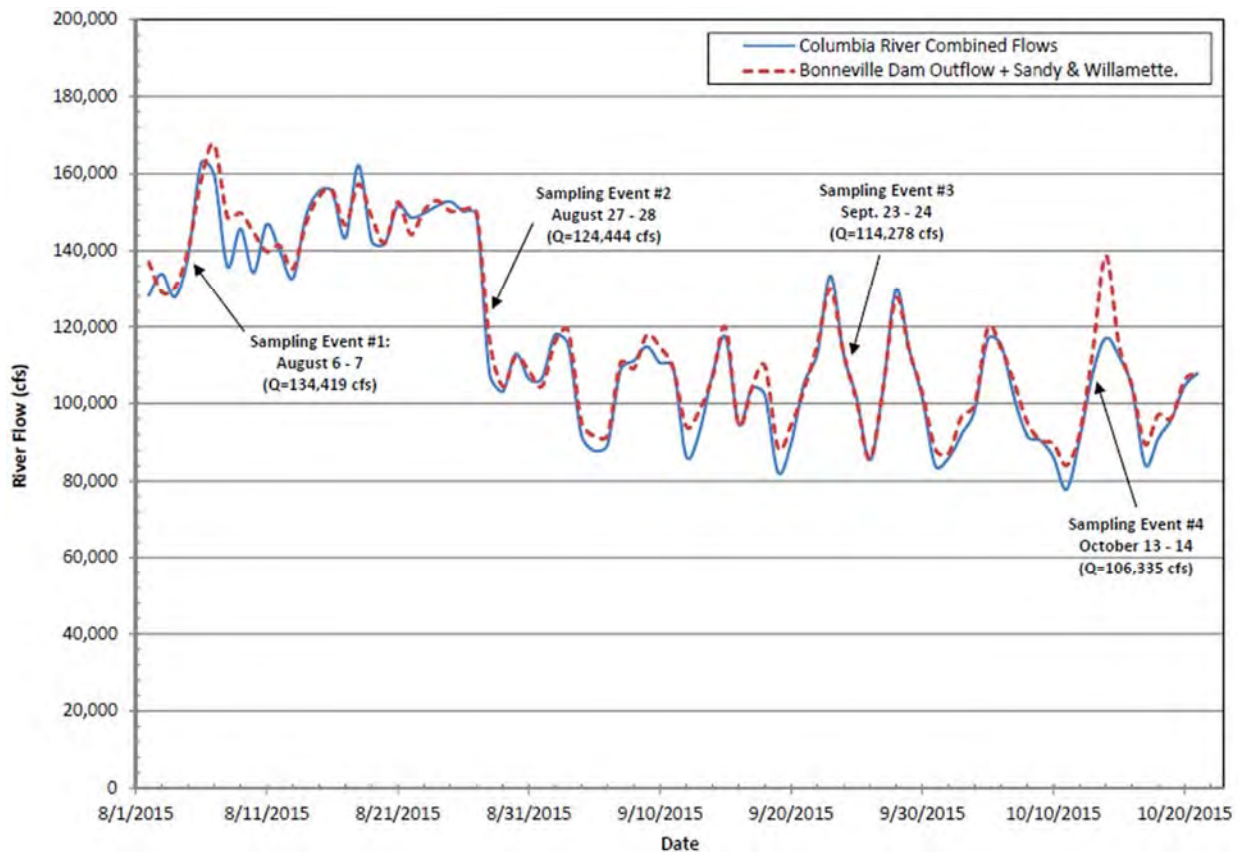


Figure 2-5. Columbia River Flow at RM 96 (Combined Upstream River Flows versus Bonneville Dam Outflow plus the Sandy and Willamette Rivers, August to October 2015)
 Engineering Report for the Phase 5A Project—Columbia River Outfall and Effluent Pipeline

2.4.1.2 River Design Flow Conditions

The lower Columbia River has three seasonal discharge periods: low flow (July through October), winter/wet season (November through March), and high flow (April through June). For modeling and hydraulic analyses, it is important to determine the statistical frequency of occurrence of low and high river flow conditions. These extreme conditions represent the lowest and highest ambient current velocities, and they typically establish the minimum dilutions for a point source discharge.

The 7Q10 and the 30Q5 flows were calculated for the low-flow period per guidance provided in Appendix C of the *Water Quality Program Permit Writer's Manual* (Permit Writer's Manual) (Ecology, 2015a). The 7Q10 flow is defined as the discharge at the 10-year recurrence interval taken from a frequency curve of annual or seasonal values of the lowest (or highest) mean discharge for 7 consecutive days (that is, the 7-day, 10-year low flow). The 7Q10 low flow corresponds to the lowest river elevation (for example, the shallowest discharge depth) and slowest ambient current speeds. For this reach of the Columbia River, this low-flow condition occurs during the late summer or early fall months (August to early October), and is considered the critical receiving water condition. Similarly, the 30Q5 flow represents the lowest mean discharge for 30 consecutive days, with a recurrence interval of 5 years. In addition, the harmonic mean discharge is calculated to represent long-term average river flows. The harmonic mean is a specific type of average that is calculated using reciprocals and it is used to average discharge flows over time periods. The 7Q10 river flow in a tidal-influenced river are applied in dilution modeling to represent the acute and chronic conditions for aquatic life criteria evaluations. The 30Q5 and harmonic mean discharge flows are applied in dilution modeling to represent conditions for human health criteria evaluations.

The 7Q10 and 30Q5 low flows were calculated from long-term Columbia River water resource records for Beaver Army Terminal near Quincy, Oregon (Gage 14246900) provided by the USGS Portland District Office. These were then adjusted (that is, subtracted from) using discharges from the upstream tributaries Lewis River at Ariel, Washington (Gage 14220500), and Cowlitz River at Castle Rock, Washington (Gage 14243000). The calculated 7Q10 and 30Q5 low flows are 83,506 and 99,893 cfs, respectively. The 7Q10 design river flow value is consistent with a previous 7Q10 low-flow calculation of 85,346 cfs that was also based on statistics from the same USGS gaging stations (CH2M HILL, 2004; 2005; 2006). The harmonic mean flow of 191,106 cfs was calculated using the same data sets.

To summarize, the Columbia River hydrologically based design flows calculated for use in dilution modeling are as follows:

- 7Q10 low flow: 83,506 cfs
- 30Q5 low flow: 99,893 cfs
- Harmonic mean flow: 191,106 cfs

2.4.1.3 Columbia River Stage

Stage elevations for the Columbia River at Vancouver, Washington, are recorded by USACE at the Interstate 5 Bridge near RM 106. The Vancouver gaging site is a National Weather Service (NWS) station with a long-term data record, and these river stage elevation data are published by the USGS as Gage 14144700. Daily average river stage elevation data were obtained from the USGS for the Vancouver gage over the most recent available record period (February 1998 to September 2015). These 17 years of elevation data are summarized in Figure 2-6. These river stage elevations are relative to the Columbia River Datum (CRD), and 1.82 feet are added to these data to adjust the elevations to NGVD29, or mean sea level (msl).

Figure 2-6 illustrates the seasonal trends in river stage elevation, with the highest seasonal stage elevations occurring in the wet season (December to February) and in the late-spring runoff period (April to June). Conversely, the lowest seasonal river stage occurs August through October. The minimum, mean, and maximum monthly river stage elevations for the Columbia River at Vancouver, Washington, are provided in Table 2-1 for the period of record water years 1973 through 2003 (USACE, 2004). A notable maximum monthly stage value of nearly 26.8 feet occurred in February 1996, coinciding with a period of extremely high winter flows and flooding on the Willamette and Columbia rivers. Maximum monthly stage values of 15.7 feet in March 1983 and 18.9 feet in June 1997 occurred in the spring, which corresponds to periods of extremely high spring flows on the Columbia River. During these periods of high-stage and high-river discharge, the effects from tides are greatly reduced.

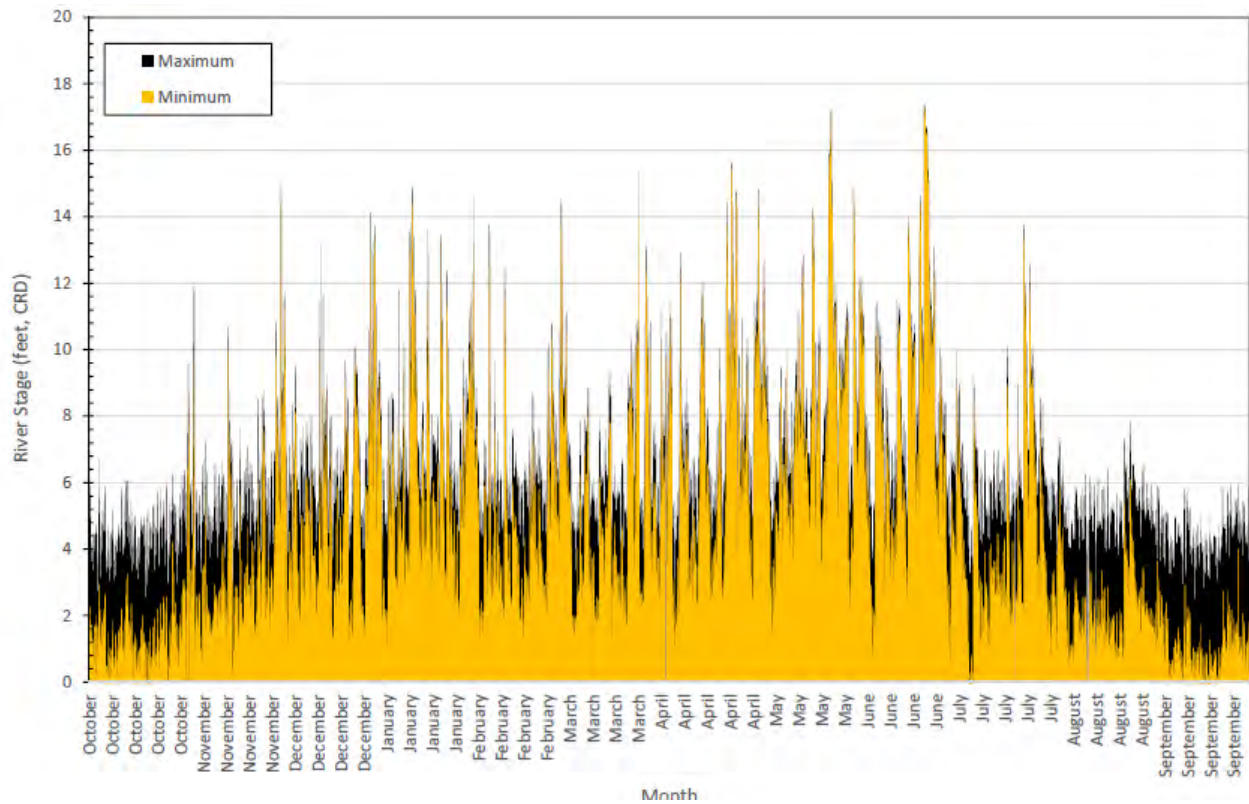


Figure 2-6. Columbia River Stage (Gage Height) Measured at Vancouver, Washington (February 1998 to September 2015)

Engineering Report for the Phase 5A Project—Columbia River Outfall and Effluent Pipeline

Table 2-1. Minimum, Mean, and Maximum Monthly Stage at Vancouver, Washington, Water Years 1973 through 2003

Month	Minimum Monthly Stage (feet)	Mean Monthly Stage (feet)	Maximum Monthly Stage (feet)
October	1.2	3.3	6.9
November	1.9	4.7	17.1
December	2.0	6.7	18.2
January	2.3	7.2	23.3
February	2.1	7.2	26.8
March	2.0	6.9	15.7
April	1.6	6.8	17.6
May	2.3	8.3	17.9
June	1.5	8.3	18.9
July	1.1	4.9	9.7
August	1.1	3.5	6.4
September	1.2	2.6	5.9

Source: USACE, 2004.

Minimum monthly stages as low as 1.1 feet was observed in July 2001. Minimum monthly stages usually occur between July and September. Tides have a pronounced influence on monthly river stages in the

summer and fall. Table 2-2 shows minimum and maximum daily stages at Vancouver, Washington. During middle to late summer, the daily stage at Vancouver typically varies as much as 3 feet because of tidal influence.

Table 2-2. Minimum, Mean, and Maximum Daily Stage at Vancouver, Washington, Water Years 1973 through 2003

Month	Minimum Daily Stage (feet)	Maximum Daily Stage (feet)
October	0.0*	7.7
November	0.3	17.5
December	1.2	18.5
January	1.6	23.3
February	1.2	27.2
March	1.0	15.7
April	1.1	17.8
May	1.4	17.9
June	0.4	21.1
July	0.1	17.8
August	0.0*	7.5
September	0.0*	7.3

Source: USACE, 2004.

*Gage zero equals 1.82 feet NGVD29.

Daily stage values are not significantly influenced by tides above a stage of approximately 12 feet (USACE, 2004). However, below a stage of 12 feet, an increasingly greater tidal effect occurs. Tidal influences are more pronounced during the summer and fall, the low-water period on both the Columbia and Willamette rivers. Daily fluctuations of several feet from the mean daily stage are common, particularly when mean daily stage is less than 5 feet. Mean daily stages equal to or less than 2.8 feet have occurred in every month of the calendar year, which indicates that there is the likelihood of some tidal influence.

Flood conditions on the Columbia River (Clark County, Washington State, and incorporated areas) were previously determined from Federal Emergency Management Agency (FEMA) floodway maps (FEMA, 2012). The recurrence intervals and their flood elevations, based on NGVD29 (equals msl) and based on CRD, are summarized as follows:

- 100-year flood: 25.6 feet (23.8 feet CRD)
- 50-year flood: 23.8 feet (21.98 feet CRD)
- 25-year flood: 22.3 feet (20.48 feet CRD) (*estimated by linear interpolation*)
- 10-year flood: 20.2 feet (18.38 feet CRD)

The effects Columbia River discharge and tides have on current velocities at the project site are discussed in Section 2.4.2.

2.4.2 Current Velocities and Tidal Influences at Columbia River Mile 96

2.4.2.1 Current Velocities

Current velocities (magnitude and direction) were measured to represent the potential outfall diffuser sites offshore of the existing outfall terminus during low river flow conditions. Other measurements by these instruments included ambient temperature, conductivity, and instrument depth. These records provide site-specific data for use in diffuser modeling and design, and these document tidal-induced flow reversals that occur near RM 96 under low river flow conditions.

CH2M scientists installed three InterOcean S4 current meters on two separate, bottom-anchored cable arrays at two potential diffuser sites on the Columbia River near RM 96. The locations of the two current meter cable arrays are shown on Figure 2-7, and are identified as Array A and Array B. Three instruments were deployed to provide redundancy of instruments in case of problems with any recordings.

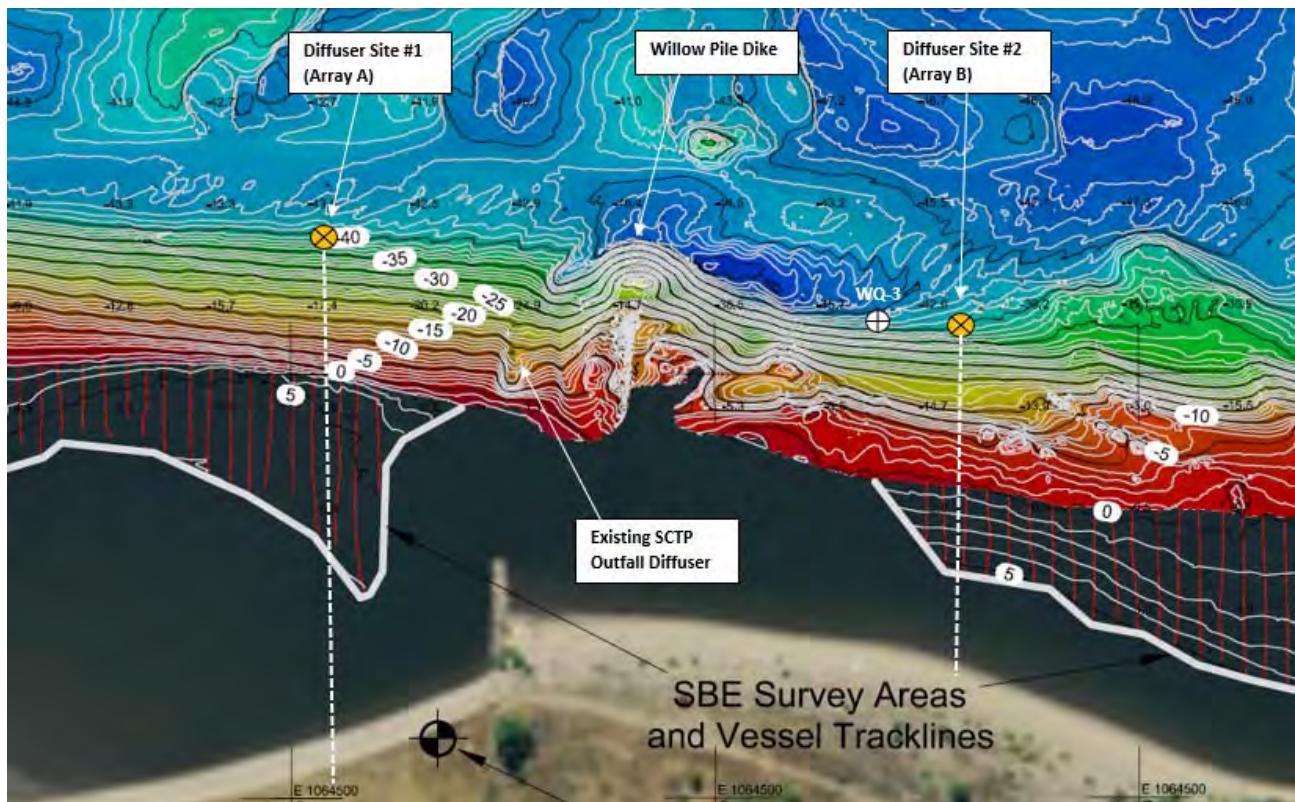


Figure 2-7. Locations of Current Meter Arrays A and B Deployed August 26 to September 25, 2015, in the Columbia River near River Mile 96

Source: Bathymetry from July 2015 survey by Solmar Hydro Engineering Report for the Phase 5A Project—Columbia River Outfall and Effluent Pipeline

The current meters were installed on taut-line cable arrays with subsurface floatation buoys anchored to the riverbed. The subsurface floatation buoys were located approximately 10 feet below the river surface (at low flow). The instrument arrays were secured using 0.25-inch galvanized steel aircraft cable with subsurface buoys, and iron anchor weights. Because of the depth of water, acoustic releases were employed. Global positioning system (GPS) coordinates were recorded for each of the arrays.

Current meter Array A (located at Diffuser Site 1 near RM 95.93) included two current meters: one positioned at 15 feet deep (near surface) and one at -30 feet deep (near-bottom). The array was located at a water depth of approximately 40 feet. Current meter Array B (located at Diffuser Site 2 near

RM 95.76) included one instrument positioned at -20 feet deep (mid-depth). Current meter Array B was located downstream of the existing outfall diffuser, at a site with water depth of approximately 40 feet. The current meters were set up to record current velocities and directions, water depths, temperature, and conductivity for 3-minute durations (every 10 minutes) continuously for a 1 month period of August 26 through September 25, 2015.

Both current meters on Array A operated flawlessly and provided 100 percent data recovery for the 1 month period. The single instrument on Array B was operating when installed, but approximately 2 hours after deployment, the internal clock battery of the meter on Array B failed. Testing conducted following instrument recovery indicated that the meter's main battery pack was fully charged and all internal connections were good. However, testing and diagnostics revealed that the meter's manufacturer-installed internal clock battery failed prematurely, which caused the instrument to fail. As a result, no useable data were recorded by this meter. Therefore, the data collected by the two meters deployed at the Array A site were used to represent currents at both potential diffuser sites. These sites are on the same depth contour and separated by approximately 800 feet.

Table 2-3 provides a summary of the current measurements collected during the low river flow period for the entire record period for the two current meters on Array A. Statistical summaries of the data records from each of the current meters are provided, and currents measured by both instruments show that average current speeds were approximately 25 centimeters per second (cm/sec) (0.8 feet per second [ft/sec]), with maximum values ranging from about 51 to 54 cm/sec (1.7 to 1.8 ft/sec).

Table 2-3. Measured Current Speeds and Directions, Depths, and Temperatures at Columbia River Mile 96, August 26 to September 25, 2015 ^a

Engineering Report for the Phase 5A Project—Columbia River Outfall and Effluent Pipeline

Current Meter Instrument	Current Speed, (mean/maximum) (cm/sec)	Average Current Direction (degrees true north)	Current Meter Depth (mean/range) (feet)	Average River Temperature (°C)
Array A – near-surface ^b	25.1/53.9	171	19.4/17.2 to 22.0	20.2
Array A – near-bottom ^b	24.9/50.6	194	34.2/32.1 to 36.9	20.2

^a The mean Columbia River discharge during the measurement period was 110,293 cfs.

^b The near-surface meter on Array A was located 15 to 20 feet below the water surface; the near-bottom current meter was located 10 feet above the riverbed.

°C = degrees Celsius

Figure 2-8 presents the current meter data as a time-series plot of current speed as a function of time. The daily average Columbia River flow is also plotted to illustrate the relationship to river discharge. The river flow over the 1-month meter deployment period averaged nearly 110,000 cfs, and ranged from 82,000 cfs (September 20) to 153,000 cfs (August 26). When plotted together, these two parameters show that general trends in river discharge (increases and decreases) over the deployment period are also reflected in the current speed record. For example, in the 11-day period from August 28 to September 7, river discharge is in a downward trend (with relatively brief increases). During this same period of time, the ambient current speeds measured also reflect a decreasing trend in speed. Similar examples are observed during other periods in the record.

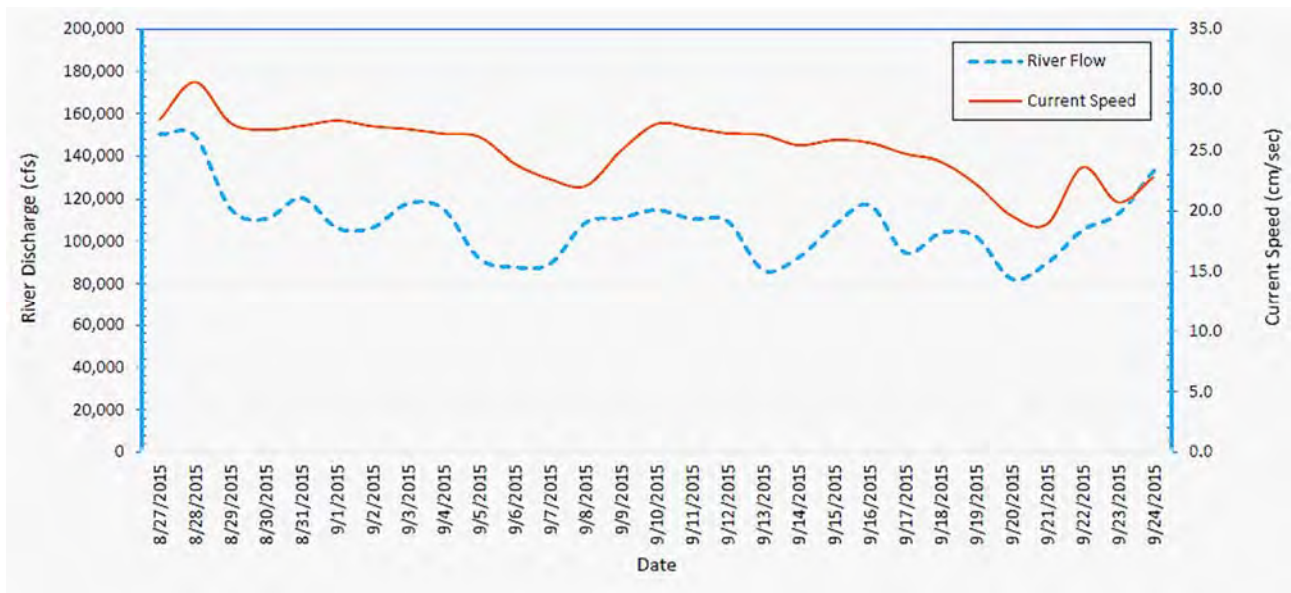


Figure 2-8. Daily Mean Columbia River Discharge and Near-surface Current Speed near Columbia River RM 96, August 26 through September 25, 2015

Engineering Report for the Phase 5A Project—Columbia River Outfall and Effluent Pipeline

Figure 2-9 presents a principal component (scatter) plot of the full current records for the near-surface instrument at current meter Array A (note: current records for the near-bottom instrument are similar and not shown). This plot shows the distribution of the current magnitude and direction relative to the principle axes of the currents. Because the river channel is in a north-south orientation, the top of the figure represents north (downstream direction) and the bottom of the figure represents south (upstream direction).

Figure 2-10 is a scatter plot that shows the current magnitude plotted as a function of direction and displays the relative occurrence of currents along the channel axis compared to those across the channel. The currents are primarily along the axis of the channel, with the majority of the records measured in a downstream direction with magnitudes between 20 and 40 cm/sec; peak cross channel currents are less than 10 cm/sec. These currents speeds and directions represent times when the current is transitioning between ebb and flood tide conditions. Peak currents during flood tide (to the south or upstream direction) are less than 30 cm/sec, with the majority of measurements under 20 cm/sec and are oriented a few degrees east of due south.

Figure 2-10 uses the near-surface current records to show the relative strength of ebb and flood tidal currents, as well as the measurements recorded during the transition from flood to ebb tide (and vice versa). Unlike Figure 2-9, this plot more effectively shows the small number of ebb-flood transition measurements relative to those measured during ebb and flood tide. Analysis of the entire record of current measurements at current meter Array A (both instruments) indicates that flood tides only occurred approximately 24 percent of the time during this late summer period and depend on river flow.

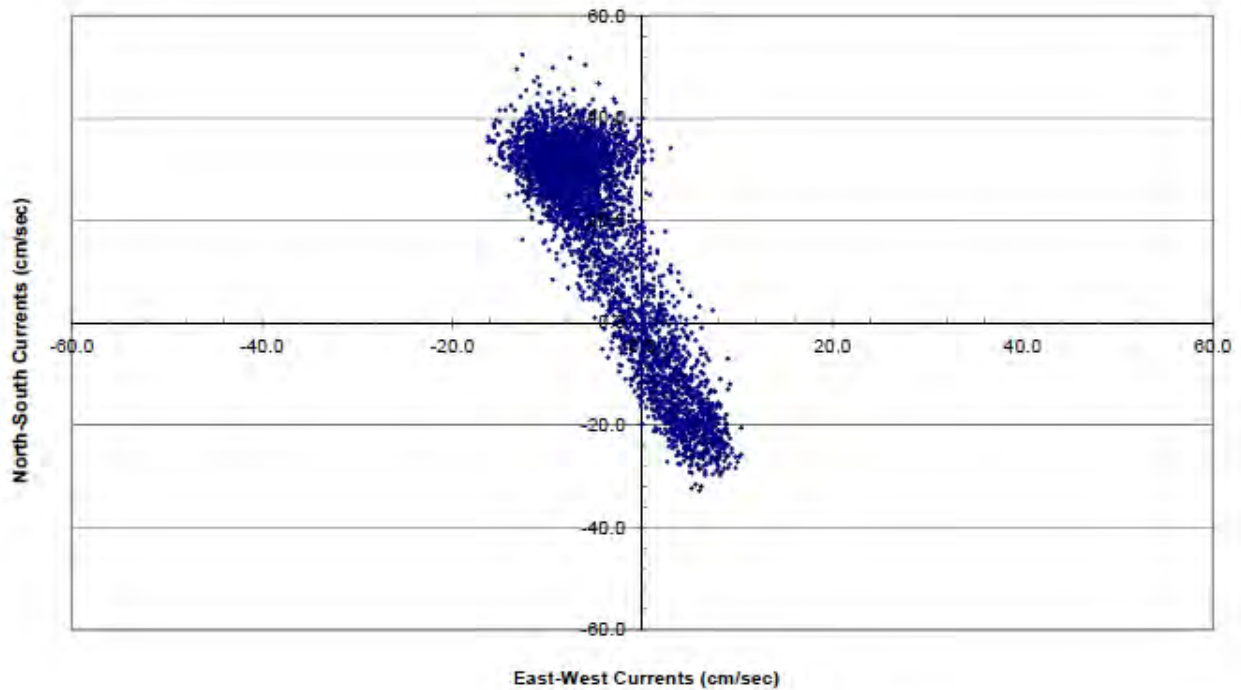


Figure 2-9. Principal Component Plot of Near-Surface Currents at Current Meter Array A near RM 96, August 26 through September 25, 2015
 Engineering Report for the Phase 5A Project—Columbia River Outfall and Effluent Pipeline

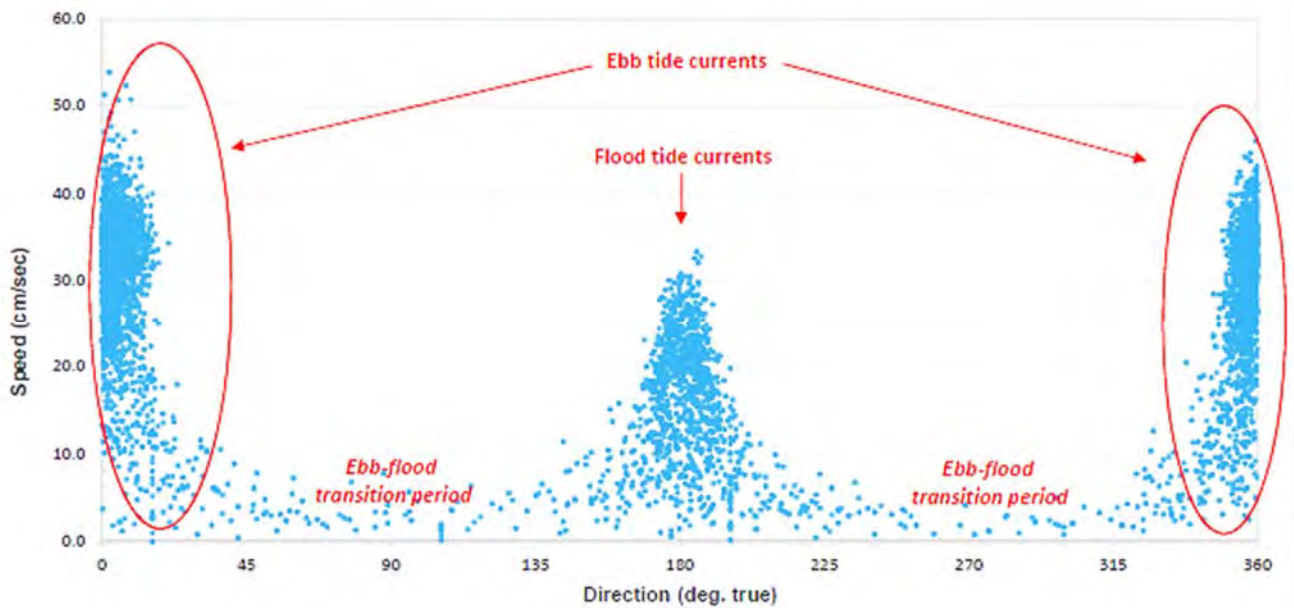


Figure 2-10. Near-Surface Current Speed and Direction in the Columbia River near RM 96 at CM Array 'A,' August 26 through September 25, 2015
 Engineering Report for the Phase 5A Project—Columbia River Outfall and Effluent Pipeline

The complete sets of current measurements are provided in Tables B-1 and B-2 on a CD in Appendix B.

2.4.2.2 Tidal Influence

There is a gradual change in the relative importance of riverine and tidal effects with distance upriver from the Pacific Ocean. The river stage (mean water level) and tidal properties at the mouth of the

Columbia River are dominated by the tides and atmospheric effects, and the river flow plays a minor role. In contrast, the river stage and currents at RM 96 are primarily dominated by the river flow. However, while stage and currents are dominated by the Columbia River discharge, significant flow reversals have been previously documented in the vicinity of the existing SCTP outfall at Vancouver, Washington, as described in the *Outfall Dilution Study Report for the Salmon Creek Wastewater Treatment Plant* (CH2M, 2004a).

As previously discussed, data obtained from the 4-week current meter deployment in August and September 2015 provided important information on the magnitude and direction of currents in the vicinity of the potential new outfall diffuser locations. These current measurements were collected to characterize the transport of the plume from the outfall diffuser during the critical (low-flow) receiving water period.

Tidal ranges in the lower Columbia River are generally around 2 to 3 feet, depending on seasonal river flow conditions and the strength of tidal conditions. Tidal effects are most pronounced during the low-flow periods during summer and fall, and are not discernible during higher flow periods during winter and spring. Tidal influences on river stage and on current magnitude and direction are more pronounced during the summer and fall, which is the low water period on the Columbia River.

During the August to October data collection events at RM 96, predicted tidal elevation data were accessed from Tides and Currents (Nobeltec, 2009) for Knapp Landing at RM 95 on the Columbia River. Appendix B includes the predicted tidal elevation plots for Knapp Landing on August 6, 7, 27, and 28; September 24 and 25; and October 13 and 14, 2015. These tidal elevation plots were used in the field to plan field sampling during ebb and flood tide conditions, as well as timing of current transport measurements (described in Section 2.4.3 below), and they proved to be very reliable.

2.4.3 Current Transport Characteristics

Current transport studies were performed to document the discharge plume trajectory from two potential new outfall diffuser sites under critical low-flow (dry season) conditions. In conjunction with the deployment of current meters at discrete locations, multiple drogues (subsurface current drifters) were released from the proposed outfall diffuser sites. These drogue releases were performed to document the transport of the river water masses from the potential diffuser locations. For these releases, 0.5-meter-square cruciform-shaped drogues (also referred to as current crosses) were deployed at approximately mid-depth (20 feet) below the water surface near the expected predicted maximum plume rise height.

The location and transport rate of each drogue deployed was tracked and recorded using a handheld GPS unit. Other observations recorded during the drogue releases included the following:

- Tide stage, weather, and water surface conditions
- Wind speed and direction
- Distance to nearest bank (measured using a laser rangefinder)
- Drogue separation distance
- Drogue status (grounding or into obstacle such as dike)

In total, 10 separate drogues were released during the four water quality sampling events in August to October 2015. To observe the effects of tidal influence on plume transport, the timing of the drogue releases was designed to coincide with ebb and flood tidal conditions.

The separation distances measured between individual drogues ranged from less than 20 feet to well over 200 feet for the majority of the drogue release periods. Close proximity (that is, separation distance) was maintained between individual drogues, which implies very little to no difference in the speed and magnitude of the water masses measured during the release period. Large drogue separation

distances imply that non-laminar current flow may be present (because of tidal effects) and the possibility of more than one water mass is being measured.

Figure 2-11 shows potential plume trajectories based on drogue releases on September 23, 2015, between 1337 hours and 1606 hours Pacific Daylight Time (PDT). During this drogue release, the tide was in the late stages of flood (moving upstream) and was transitioning into ebb tide. Two drogues were released from the potential new diffuser location at Site 1 (location of current meter Array A) during a late flood tide. This proposed diffuser site is located offshore, and slightly upstream, of the existing outfall diffuser at a depth of approximately 40 feet.

From Site 1, both drogues were released at late-flood tide and (denoted in Figure 2-11 by the white vectors) traveled upstream (south) for a distance of approximately 450 feet over approximately 20 minutes, which is a transport rate of approximately 0.4 ft/sec (12 cm/sec). The drogues then reversed direction and traveled downstream for approximately 200 feet. The white vectors upstream of Site A in Figure 2-11 denote the reversal in direction of the drogues shortly before the start of ebb tide. Both drogues were then deployed a second time at Site 1, and traveled downstream while approximately 20 feet apart for a distance of approximately 1,500 feet over 28 minutes (a transport rate of about 0.9 ft/sec (27 cm/sec). Drogue 2 (red vectors) then traveled another 1,800 feet downstream and Drogue 4 (yellow vectors) another 1,300 feet downstream over approximately 20 minutes.



Figure 2-11. Probable Discharge Plume Trajectory Plot from Drogues Released at Potential Diffuser Site 1 (Array A) near Columbia River Mile 96 on September 23, 2015

Source: CH2M HILL modified from Google Earth, 2015

Engineering Report for the Phase 5A Project—Columbia River Outfall and Effluent Pipeline

These drogue plots show good agreement with the current meter records for this period: the mean mid-depth current measured by these instruments during this 2.5-hour release period averaged 15 cm/sec, with speeds ranging from 1.6 to 28.2 cm/sec (depending on tide conditions). Most importantly, these

drogue trajectories show that from this proposed diffuser site (Site 1), a plume discharged from this location would stay well within the river channel and would likely avoid contact with the shoreline for at least 1 mile travel distance where the plume would be highly diluted and dispersed.

Figure 2-12 is a schematic representation of the plume trajectory based on drogues released on October 14, 2015, between 1434 hours and 1551 hours PDT. During this drogue release period, the tide transitioned from late ebb through slack water into early flood tide. The observed tide reversed at approximately 1530 hours, which was approximately 15 minutes after the predicted slack water.

Drogue 2 (red vectors) was released from Site 2 (location of current meter Array B) and traveled downstream during late ebb tide conditions approximately 1,100 feet over 40 minutes (a transport rate of approximately 0.5 ft/sec (14 cm/sec). Drogue 2 then reversed direction and traveled back upstream for approximately 530 feet over about 15 minutes (a transport rate of about 0.6 ft/sec, [18 cm/sec]). Drogue 4 (yellow vectors) followed a similar trajectory while staying within approximately 250 to 300 feet of Drogue 2.



Figure 2-12. View of Probable Discharge Plume Trajectory Plot from Drogues Released at Potential Diffuser Site 2 (Array B) near Columbia River RM 96 on October 14, 2015

Source: CH2M HILL modified from Google Earth, 2015
Engineering Report for the Phase 5A Project—Columbia River Outfall and Effluent Pipeline

The trajectories of the drogues released from the two potential outfall diffuser locations demonstrate that the discharge plume trajectories remain parallel to the axis of the river channel and offshore of the shoreline. Minor deviations from this transport pattern are likely because of the effects on laminar flow by local bathymetry and by the presence of obstructions, such as the pile dikes. The results of this current transport study provide a good representation of where the plume discharge from a new outfall diffuser at Site 1 or Site 2 would be transported under low river flow conditions and different tidal conditions.

2.4.4 Water Quality Sampling at Columbia River Mile 96

2.4.4.1 Water Quality Measurements

Water quality sampling was conducted in four, 2-day sampling events during August, September, and October 2015 during summer low river flow conditions. The water quality sampling was conducted in accordance with the QAPP (CH2M, 2015). The water quality sampling included the following three elements:

1. Water quality measurements in vertical water column profiles at five Columbia River sampling sites during ebb and flood tides during each of the four river sampling events
2. Continuous in situ water quality measurements at mid-water depth using an anchored instrument during the river sampling events
3. Collection of background Columbia River water samples at a site upstream of the existing SCTP outfall (during ebb tide) during each of the four river sampling events

The locations of the water column profile stations, continuous water quality monitoring station (WQ-2), background river sampling site, and the potential replacement outfall diffuser sites are shown in Figure 2-2.

Water column measurements of temperature, conductivity, turbidity, pH, and dissolved oxygen were recorded in vertical water column profiles during ebb and flood tide conditions over the 2-day study periods of August 6 to 7, August 27 to 28, September 23 to 25, and October 13 to 15, 2015. These measurements were all recorded during summer low river flow conditions. Columbia River water column measurements were recorded using a Sea-Bird SBE19 PlusV2, multi-parameter water quality field instrument. The Sea-Bird SBE19 PlusV2 was equipped to measure pressure (instrument depth), temperature, conductivity, dissolved oxygen, pH, and turbidity. Measurements were recorded at a frequency of four times per second. During data processing, the data were bin-averaged at 0.5-foot intervals from the water surface to just above the bottom. On August 27 to 28, separate pH measurements were collected by profiling using an EcoSense pH 100A instrument.

A total of 85 water quality profiles (casts) were completed at water quality sampling sites WQ-1, WQ-2, WQ-3, WQ-4, and WQ-5 on August 6 to 7, August 27 to 28, September 23 to 25, and October 13 to 15, 2015. These water column profile measurements are provided in Appendix C as follows: Tables C-1 through C-20 for August 6 to 7; Tables C-21 through C-40 and Table C-42 (pH profiles) for August 27 to 28; Tables C-43 through C-62 for September 23 to 25; and Tables C-64 through C-88 for October 13 to 15, 2015.

In addition to the extensive water quality profiles, continuous in situ water quality measurements were recorded using an In-situ Troll 9500 Water Quality Instrument at water quality monitoring station WQ-2. The instrument was attached at mid-water depth to a taut-line buoyed vertical cable, anchored at WQ-2 during the river sampling events on August 27 to 28 (25 hours of measurements), September 23 to 25 (43 hours of measurements), and October 13 to 15 (42 hours of measurements). The In-situ Troll 9500 Water Quality Instrument was equipped to measure pressure (instrument depth), temperature, conductivity, dissolved oxygen, pH, and turbidity. Measurements were recorded at a frequency of once

every 30 seconds for at least 24 hours to provide reading throughout both daylight and nighttime hours. These continuous water quality measurements in the Columbia River are provided on a CD in Appendix C as follows: Table C-41 for August 27 to 28; Table C-63 for September 23 to 25; and Table C-89 for October 13 to 15.

These water quality profiles and continuous measurements show water temperatures remained between 21 and 22 degrees Celsius (°C) during the August sampling events, dropped to 18 to 19°C during September sampling, and were 17 to 18°C in October. Temperatures were observed to vary by less than 0.1°C from the surface to the river bottom. Similarly, conductivity was observed to be nearly constant at or near 0.13 microSiemen per centimeter ($\mu\text{S}/\text{cm}$) from surface to bottom and between stations. Measurements of pH were consistently near 8.0 units and ranged from 7.6 to 8.3 pH units. Turbidity measurements show consistent values of 1 to 2 or just above 2 nephelometric turbidity units in the water column. Dissolved oxygen values ranged from about 8 to just over 12 milligrams per liter (mg/L) throughout the water column.

In summary, the extensive water quality measurements in the Columbia River near RM 96 yielded no exceedances of Washington State surface water quality standards for pH, dissolved oxygen, and turbidity. All river pH values were within the freshwater criteria range of 6.5 to 8.5. All river dissolved oxygen values were greater than the freshwater criteria of 8.0 mg/L for salmonid spawning, rearing, and migration; and all dissolved oxygen saturation values exceeded the 90 percent threshold. All river turbidity values were within the turbidity criteria limits. River temperatures exceeded 20°C because of natural conditions in the river.

2.4.4.2 Background River Water Chemistry

Background Columbia River water samples were collected during each of four separate sampling events during August, September, and October 2015. These water quality sample collections and analyses were conducted in accordance with the QAPP (CH2M, 2015). The background water samples were collected at water quality monitoring station WQ-2 under ebb tide conditions (refer to Figure 2-2).

Table 2-4 provides a summary of the background Columbia River water chemistry results for the four dry season sampling events. The complete data sets of the twelve river water samples are provided in Appendix C-5. These background water chemistry values are all substantially less than the water quality criteria for the protection of aquatic life and criteria for the protection of human health.

Table 2-4. Summary of Background Columbia River Analytical Chemistry Results for Four Dry Season Sampling Events in 2015
Engineering Report for the Phase 5A Project—Columbia River Outfall and Effluent Pipeline

Analyte	Units	MRL	August 6, 2015			August 27, 2015			September 24, 2015			September 24, 2015		
			Detects	Upper 90th	Mean	Detects	Upper 90th	Mean	Detects	Upper 90th	Mean	Detects	Upper 90th	Mean
pH	pH UNITS	N/A	3	8.00	7.99	3	7.76	7.74	3	8.07	8.05	3	7.91	7.89
Total Suspended Solids (TSS)	mg/L	2.5	3	27.9	13.7	3	3.6	3.4	3	2.9	2.6	3	2.9	2.8
Total Dissolved Solids (TDS)	mg/L	25	3	82.4	77.3	3	85.6	76.7	3	62.0	55.0	3	103.8	95.3
Hardness, Total as CaCO ₃	mg/L	3.31	3	58.6	57.9	3	60.2	59.9	3	64.2	63.7	3	62.6	61.5
Alkalinity, Bicarbonate, CaCO ₃	mg/L	5	3	55.1	54.8	3	56.8	56.3	3	56.6	55.6	3	60.8	59.9
Alkalinity, Carbonate, CaCO ₃	mg/L	5	0	5U	5U	0	5U	5U	0	5U	5U	0	5U	5U
Alkalinity, Total as CaCO ₃	mg/L	5	3	55.1	54.8	3	56.8	56.3	3	56.6	55.6	3	60.8	59.9
Phosphate, Total as P	mg/L	0.01	3	0.0063	0.0049	3	0.0190	0.0164	3	0.0191	0.0158	3	0.0173	0.0158
Phosphate, Ortho as P	mg/L	0.01	3	0.0107	0.0098	3	0.0163	0.0141	3	0.1404	0.0648	3	0.0260	0.0241
Nitrate/Nitrite-N	mg/L	0.01	3	0.0774	0.0744	3	0.9348	0.7057	3	0.4056	0.2746	3	0.1770	0.1763
Total Kjeldahl Nitrogen as N	mg/L	0.2	3	0.594	0.469	1	0.116	0.116	3	0.167	0.146	3	0.193	0.182
Ammonia-N	mg/L	0.1	2	0.0372	0.0326	2	0.0232	0.0224	2	0.0385	0.0345	3	0.0509	0.0398
Arsenic	µg/L	0.5	3	0.937	0.931	3	0.878	0.861	3	0.912	0.908	3	1.084	1.063
Cadmium	µg/L	0.5	0	0.03U	0.03U	0	0.03U	0.03U	0	0.03U	0.03U	3	0.074	0.069
Chromium	µg/L	1	3	0.121	0.118	3	0.253	0.232	3	0.157	0.148	3	0.205	0.181
Copper	µg/L	2	3	0.614	0.577	1	0.592	0.520	0	0.5U	0.5U	1	0.545	0.520
Lead	µg/L	0.5	3	0.087	0.074	3	0.112	0.107	3	0.107	0.090	3	0.313	0.175
Selenium	µg/L	0.5	3	0.221	0.205	3	0.269	0.260	3	0.195	0.176	3	0.300	0.275
Silver	µg/L	0.5	0	0.025U	0.025U	0	0.025U	0.025U	0	0.025U	0.025U	0	0.025U	0.025U
Thallium	µg/L	0.2	0	0.025U	0.025U	0	0.025U	0.025U	0	0.025U	0.025U	1	0.027	0.027
Zinc	µg/L	10	0	2.5U	2.5U	1	2.540	2.540	0	0.5U	0.5U	0	0.5U	0.5U
Mercury	NG/L	1	3	0.934	0.761	3	2.326	1.462	3	0.588	0.551	3	1.044	0.808
Arsenic, Dissolved	µg/L	0.5	3	0.914	0.903	3	0.881	0.877	3	0.869	0.865	3	1.000	0.997
Cadmium, Dissolved	µg/L	0.5	0	0.03U	0.03U	0	0.03U	0.03U	0	0.03U	0.03U	3	0.099	0.079
Chromium, Dissolved	µg/L	1	3	0.466	0.358	3	0.197	0.174	3	0.480	0.454	3	0.447	0.407
Copper, Dissolved	µg/L	2	2	0.577	0.577	0	0.5U	0.5U	0	0.5U	0.5U	1	0.811	0.650
Lead, Dissolved	µg/L	0.5	1	0.057	0.057	3	0.120	0.090	2	0.043	0.042	0	0.0407U	0.0407U
Selenium, Dissolved	µg/L	0.5	3	0.250	0.225	3	0.277	0.273	3	0.203	0.149	3	0.218	0.200
Silver, Dissolved	µg/L	0.5	0	0.025U	0.025U	0	0.025U	0.025U	0	0.025U	0.025U	0	0.025U	0.025U
Thallium, Dissolved	µg/L	0.2	0	0.025U	0.025U	0	0.025U	0.025U	0	0.025U	0.025U	0	0.025U	0.025U
Zinc, Dissolved	µg/L	10	0	2.5U	2.5U	0	2.5U	2.5U	0	2.5U	2.5U	0	2.5U	2.5U

Note:

Blue shading indicates result was less than the method detection limit

µg/L = micrograms per liter

MRL = method reporting limit for analysis

N/A = not applicable

NG/L = nanograms per liter

U = Laboratory reported undetected

2.4.5 River Bathymetry, Geomorphology, and Bedforms

This section describes and reviews the existing bathymetry of the outfall project area and briefly reviews the geomorphology of the lower Columbia River at RM 96 as it relates to the design of the new SCTP outfall and diffuser. In addition, a detailed river bedform transport evaluation was developed in 2016 and a detailed shoreline stability evaluation was developed in 2017; these are summarized in technical memoranda provided in Appendix D.

2.4.5.1 River Bathymetry

The bathymetry of the Columbia River between RM 96.25 and 95.50 and the effluent pipeline corridor reaches crossing Lake River and Salmon Creek were surveyed on July 22 and July 29, 2015, by Solmar Hydro, Inc. The detailed multi-beam bathymetric survey charts (contour plots) of the Columbia River region offshore, upstream, and downstream of the existing SCTP outfall are provided in Figure 2-13. The detailed multi-beam bathymetric survey charts of the Lake River and Salmon Creek reaches are provided in Figure 2-14. Figures 2-13 and 2-14 are provided at the end of this report section. These surveys are plotted based on the National Geodetic Vertical Datum 1988 (NAVD88) and the North American Datum of 1983/91 (NAD83/91) for State Plane Coordinate System, Washington South Zone (U.S. Survey Feet). In March 2017, additional bathymetric surveys were conducted by Solmar Hydro during high river stage to allow access to nearshore areas of the Columbia River at RM 96 and in the Salmon Creek effluent pipeline route.

Some obvious features worth noting on the Columbia River chart are the existing outfall structure covered by riprap (bottom center of map), which terminates at a depth of approximately 15 feet below NAVD88; the Willow Pile Dike located approximately 150 feet downstream (north) of the existing outfall; and the presence of bedforms (sand waves) that increase in amplitude with increasing water depth. The sand waves are oriented perpendicular to the ambient river current direction.

In the locations of the potential new diffuser sites, 400 feet upstream and downstream of the Willow Pile Dike, the survey revealed a relatively gentle bottom slope out to a depth of about 45 feet below NAVD88. The majority of the larger (higher amplitude) bedforms appear to occur at depths greater than approximately 45 feet below NAVD88, closer to the edge of the navigation channel.

While bedforms in the vicinity of the proposed diffuser sites (targeted depth of 40 feet) display smaller amplitude, it is still possible that these bedforms could jeopardize the function of the diffuser section. This could occur as the sand wave crests and troughs alternately bury and expose the outfall. A detailed bedform modeling evaluation was developed in 2016 for the potential diffuser sites; this is discussed in Section 2.4.5.3, River Bedforms and Shoreline Stability.

2.4.5.2 Geomorphology

The geomorphology of the lower Columbia River is complex and has been formed over time by numerous natural processes, including glaciation, volcanism, hydrology, and the erosion and deposition of sediments. The Columbia River has also been substantially altered by impoundment, channel modification, flood control, and flow regulation. Channel erosion and deposition are dependent on the stability of the riverbank, upstream watershed conditions, seasonal river discharge, and channel maintenance (dredging) activities.

The discharge of the lower Columbia River is strongly influenced by seasonal climatic variations and tides. The tidal influence on water surface elevation is evident as far upstream as Bonneville Dam, which is located at RM 145. During low river flow periods, tides have been shown to cause reversals in river flow as far upstream as RM 102 (near Vancouver, Washington).

The lower Columbia River forms numerous elongated islands that divide the river and create sloughs and side channels. The floodplain expands around the Columbia River's confluence with the Willamette

River, where sand islands form the sloughs and lakes of North Portland, Sauvie Island, and the Vancouver, Washington, lowlands.

The reach of the Columbia River from the mouth of the Willamette River at Portland (RM 100) to Cathlamet, Washington (RM 50), is characterized by a relatively straight section of channel (with slight meanders), a low-gradient channel slope, and a sand-dominated riverbed channel. Downstream of Vancouver, the Columbia River cuts through the Coast Range Mountains, a reach that features steep bluffs and broad, well-developed floodplains. Below about RM 35, the river channel is characterized by numerous low islands of deposited sediments throughout its lower reaches, and it opens out (widens) as it approaches the estuary and the Pacific Ocean.

The lower Columbia River is a dynamic sedimentary environment. In the lower Columbia River, sedimentation processes such as riverbed erosion and deposition are site-specific and depend on a number of factors. These include river discharge rate, the size and composition of the sediment, the extent and frequency of dredging, tidal influence, wind effects (wind-induced waves), proximity to structures such as pile dikes and groins, and vessel traffic.

The erosion and deposition patterns observed at the SCTP replacement outfall site will affect the location, design, and maintenance of the new outfall and diffuser. The primary mechanism for bedload transport is the river discharge, which is seasonal in nature. Tides, wind, and vessel-induced waves and wakes provide relatively minor contributions.

Columbia River flows typically must exceed approximately 300,000 cfs before bedload material begins to migrate downstream. This typically is in response to spring runoff in May through June, or during large wet weather events that occur in the winter. When Columbia River flows exceed about 400,000 cfs, sand waves can migrate several feet per day. The majority of riverbed material in this river reach travels as bedload and consists of clean, unconsolidated medium to coarse sand.

2.4.5.3 River Bedforms and Shoreline Stability

Potential sites for the SCTP replacement outfall diffuser in the Columbia River have been identified and seasonal and long-term bedform changes at a diffuser site could impact the function of the diffuser. This could occur as the sand wave crests and troughs, alternately burying and exposing the outfall diffuser ports. A detailed river bedform analysis was developed to evaluate river bedform height variability at the potential diffuser site. GIS-based and Excel-based analyses were developed to estimate maximum bedform heights in the Columbia River at RM 96. The GIS analysis used historic hydrographic survey results to calculate bedform shape parameters at the project site. The Excel-based analysis used empirical equations developed by notable sediment transport expert Leo van Rijn (1982, 1984) to estimate bedform height and length based on local hydraulic and sediment conditions. A comparison of the two methods was conducted to provide support for estimating maximum riverbed dune heights expected at the project site to inform outfall diffuser riser design.

High resolution hydrographic data sets have been recorded in the vicinity of the proposed new outfall diffuser site in the river and these have been evaluated in detail. The maximum bedform heights in the river upstream of the proposed new outfall diffuser site (at -35 to -45-foot depths) reach 2 to 4 feet. The bedform heights increase with increased depth and distance off the base of the nearshore slope (offshore of the proposed diffuser site). The outfall diffuser riser heights will need to accommodate potential future bedform dunes of this magnitude without compromising the hydraulic performance of the outfall. This approach would account for uncertainty in the future development of the dune field at the outfall site. The *Columbia River Bedform Analysis for Salmon Creek WWTP – Columbia River Outfall and Effluent Pipeline Project* (CH2M, 2016a) is provided in Appendix D-1.

The Columbia River shoreline at the existing SCTP outfall site has eroded dramatically in the past 25 years. Riprap has been placed over an approximately 150-foot length of the existing outfall pipe to

cover the exposed pipe and forestall further erosion. A shoreline erosion assessment at the proposed outfall route into the Columbia River near RM 96 has been developed. The proposed outfall will be routed approximately 200 feet south (upstream) of the existing SCTP outfall alignment. The proposed alignment traverses a historic sand deposit that is higher than the surrounding ground elevation; this shoreline feature has undergone significant erosion in the past 25 years. The assessment provides estimates on the historic rate of shoreline retreat near the existing and proposed replacement outfall and estimates of expected future shoreline evolution. The intent of the analysis is to recommend the vertical placement of the outfall pipeline to ensure the long-term stability of the pipeline.

The shoreline stability assessment included reviews of historical aerial imagery and GIS analysis of shoreline movement over the period of record, a site visit by a geomorphologist/river engineer, development of a conceptual site model, and development of preliminary RMA2 two-dimensional hydrodynamic model simulations.

The GIS-based review of historical aerial imagery indicates that the sandy riverbank upstream of the existing outfall is eroding in a uniform fashion at a rate of between 4 to 10 feet per year on average, with erosion rates decreasing in more recent periods. Historical shoreline erosion rates were 10 feet per year on average between 1990 and 2002, 5 feet per year on average between 2002 and 2010, and 5 feet per year on average between 2002 and 2016. Erosion is likely largest when river flows are above a critical level such that the water level encroaches onto the sandy bank and direct mass wasting from currents and incident waves occurs.

In order to protect the proposed effluent pipeline from waves and currents, the pipeline design will rely on historic erosion rates to estimate the depth of burial required to keep the pipe covered over its design life. Another option would be to stabilize the eroding bank by laying it back to a lower angle (maybe 3H:1V) and planting it with native riparian vegetation. Preliminary indications are that burial of the pipe is the preferred method to reduce the likelihood of continued erosion affecting the new buried outfall pipeline, and that improved shoreline stability via earthwork or vegetation planting is not under consideration. However, if future shoreline monitoring indicates increased shoreline loss and threat to the new buried outfall pipeline, then shoreline earthwork and planting would need to be developed and implemented.

The removal of the existing riprap covering the existing outfall pipe may be required by the DNR under the conditions of the existing pipeline easement after the existing outfall ceases to discharge. Removal of the existing riprap may increase shoreline erosion downstream of the existing outfall in the near term, may not have a long-term effect on the bank erosion along the outfall route. The shoreline stability analysis provides recommendations for the vertical placement of the outfall pipeline. The *Columbia River Shoreline Stability Assessment for the Proposed Salmon Creek WWTP Outfall Replacement Project* (CH2M, 2017) is provided in Appendix D-2.

2.4.6 Sediments Evaluation

In 2015, the Alliance renewed the easement for the existing SCTP outfall pipeline with the DNR. Site-specific sediment sampling and analyses were required to satisfy Exhibit B in the 2015 amendment of the easement agreement for state aquatic lands issued by DNR. The DNR easement requires preparation and agency approval of sampling and analysis plans (according to agency-specific guidance), field sampling of sediments proximate the active diffuser, laboratory chemical and physical analyses, and reporting to DNR and Ecology.

A *Sampling and Analysis Plan for the Salmon Creek Treatment Plant Outfall Sediment Evaluation* (CH2M, 2016b) was developed and submitted to DNR for review and approval before sampling. A sediments evaluation was developed in 2016 following sediment sample collections along the selected outfall route in the river, and based on physical and chemical analyses of sediments.

These river sediment analyses were compared to the Sediment Evaluation Framework freshwater screening levels (USACE, 2009) and the sediment results were submitted to USACE in the *Sediment Evaluation of the Salmon Creek Treatment Plant Outfall Site* (CH2M, 2016c), which documented that the sediments along the outfall construction route can be side-cast in place and are suitable for unconfined, aquatic placement; and that additional sediment characterization is not required.

Sediment samples were collected and analyzed to evaluate the chemical and physical condition of the riverbed sediments in the area of the DNR easement for the SCTP outfall diffuser. The following were specific objectives of the study:

- Characterize in-situ riverbed material that may be disturbed in the future, in accordance with Ecology’s Sediment Cleanup Users Manual II (SCUM) (Ecology, 2015b).
- Characterize the in-situ riverbed material for evaluation of potential environmental impacts of potential future in-water activities.

Four sediment samples were collected to evaluate the riverbed surface sediments in the DNR easement at four locations where the SCTP outfall diffuser is located at RM 96 in the Columbia River. In addition, one field duplicate was collected at sampling station D-3, for a total of five grab samples. These samples were analyzed for the following:

- Conventional/physical parameters: particle size (sieve and hydrometer), total solids, total volatile solids, total organic carbon, ammonia, and total sulfides.
- Total metals including arsenic, cadmium, chromium, copper, lead, mercury, nickel, selenium, silver, and zinc.
- Organic chemicals: 4-methylphenol, benzoic acid, dibenzofuran, and phenol; phthalates - bis(2-ethylhexyl)phthalate, di-n-butyl phthalate, di-n-octyl phthalate; pesticides and PCBs - beta-Hexachlorocyclohexane, carbazole, Dieldrin, Endrin ketone, total Aroclors, total DDDs, total DDEs, total DDTs; total polycyclic aromatic hydrocarbons (PAHs); bulk total petroleum hydrocarbons (TPH) - TPH-Diesel and TPH-Residual; and pentachlorophenol.

The study was designed to meet the requirements set forth in Ecology’s SCUM II guidance. All data collected during the project were evaluated against individual method requirements, EPA guidelines, and the project Sampling and Analysis Plan. Sediment samples were evaluated against the freshwater suite listed in the *Development of Benthic SQVs for Freshwater Sediments in Washington, Oregon, and Idaho* (Ecology, 2011a).

These sediment analytical results have been reviewed and accepted by CH2M as fully usable for the project objectives. The results of this study indicate that the in-situ riverbed surface sediments in the vicinity of the SCTP outfall diffuser meet Ecology’s freshwater sediment quality values. No evidence of sediment contamination was identified in any sampling locations either upstream or downstream of the outfall diffuser. Sampled sediments were dominated by fine sands (percent by weight), and none of the samples yielded detectable levels of total sulfides, pesticides, or PCBs.

The study report *Sediment Evaluation of the Salmon Creek Treatment Plant Outfall Site* (CH2M, 2016c) is provided in Appendix E.

2.4.7 Geotechnical Investigation

The geotechnical field investigation program consisted of 10 onshore soil borings (designated B-1 through B-10), and two offshore soil borings (designated B-11 through B-12). Borings B-1 through B-4 were conducted from August 31, 2015, through September 4, 2015. Borings B-5 through B-12 were conducted from July 24, 2017, through August 28, 2017. The 12 soil borings were advanced by Western States Soil Conservation, Inc., of Hubbard, Oregon. Borings B-1 through B-4, B-9, and B-10 were

advanced using a Central Mine Equipment (CME)-850 track-mounted drill rig. Borings B-5 through B-8 were advanced using a CME-55 track-mounted drill rig. The offshore borings B-11 and B-12 were advanced from a barge using a CME-55 truck-mounted rig. Groundwater monitoring piezometers were installed within geotechnical borings B-5, B-7, B-8, B-9, and B-10.

A laboratory testing program was conducted to provide classification and engineering properties of select soil samples collected during the geotechnical field exploration program. Testing of samples was completed by Northwest Testing, Inc., of Wilsonville, Oregon, and Benchmark Geolabs, of McMinnville, Oregon.

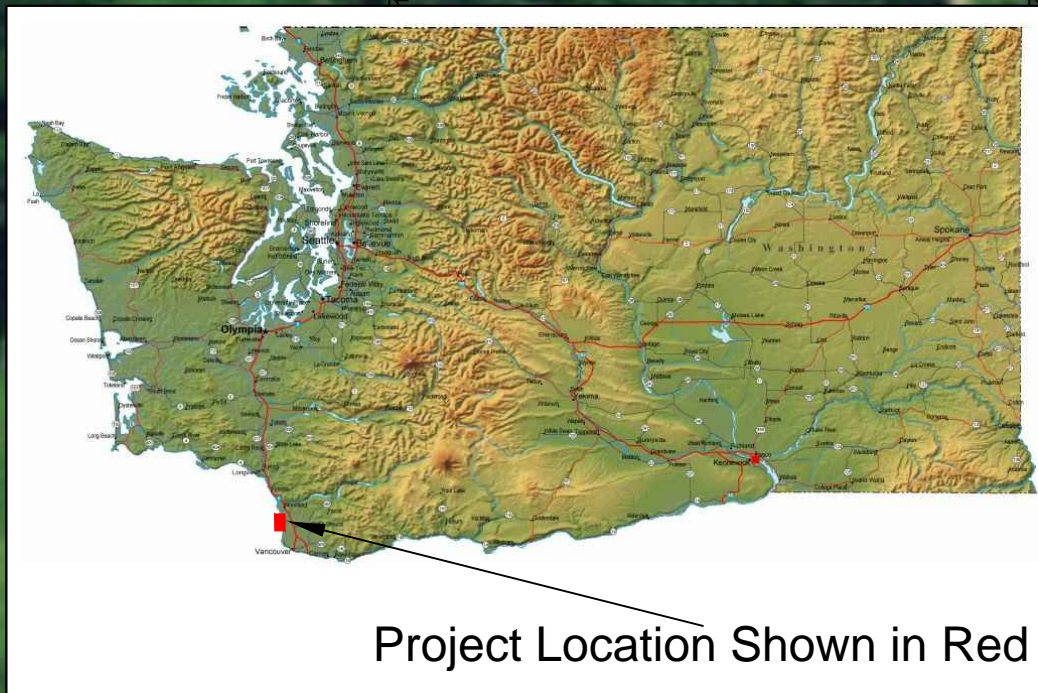
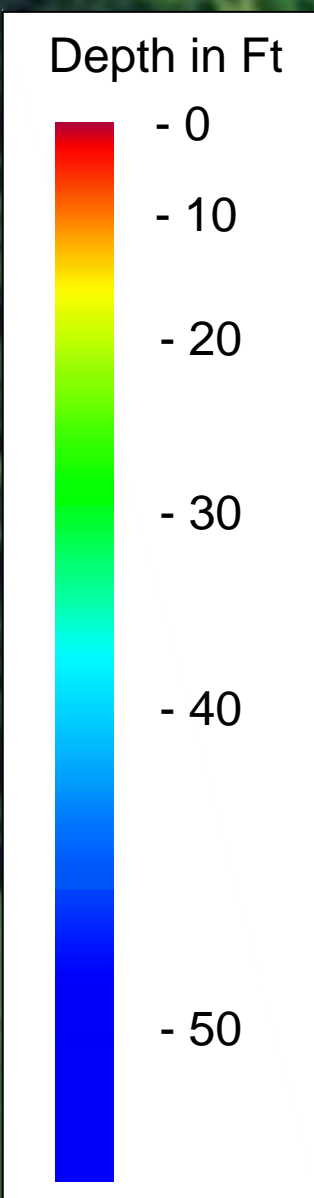
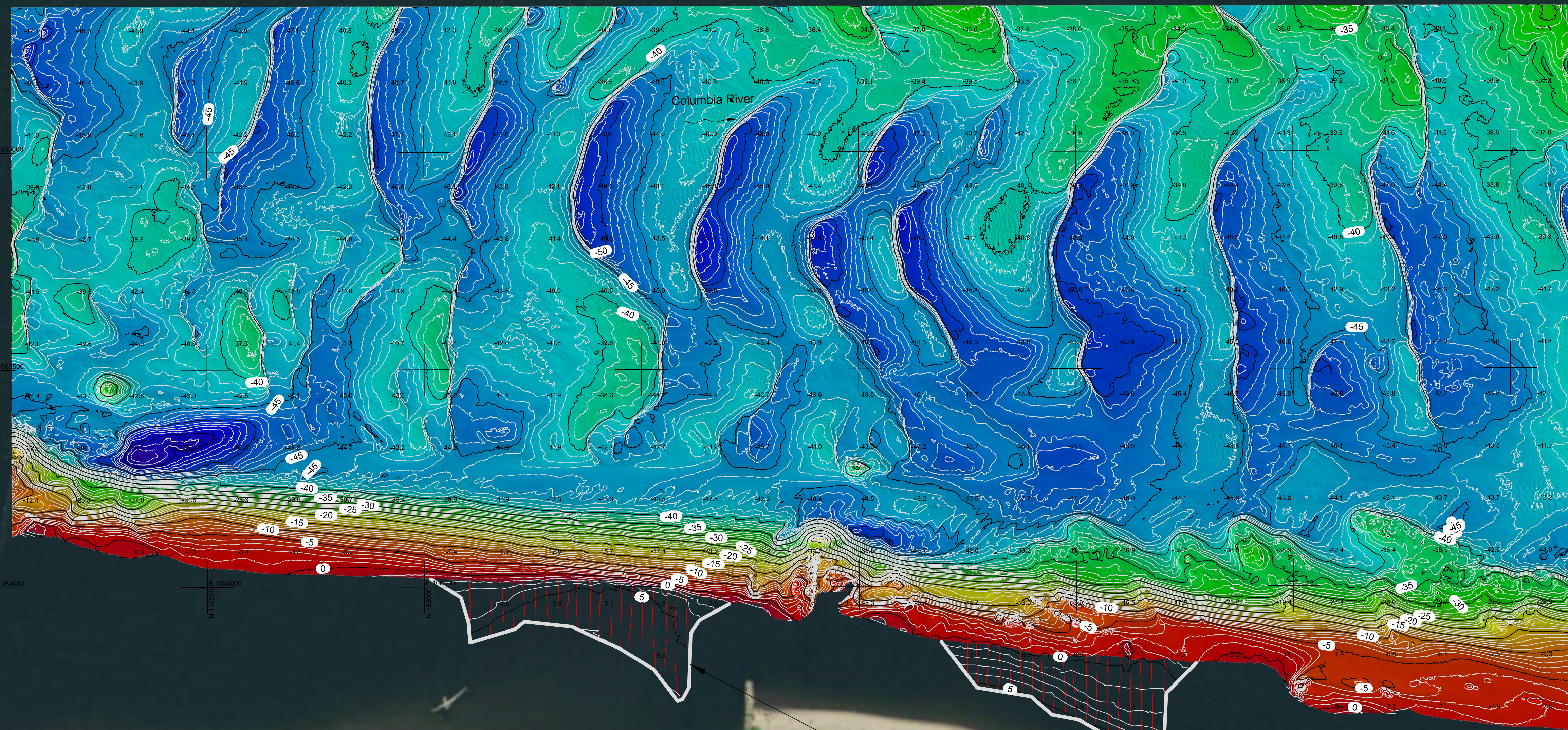
A number of previous geotechnical investigations have been completed in the vicinity of the project. The majority of these explorations have been completed in the vicinity of the SCTP, but some have included borings in the vicinity of the proposed outfall alignment. Explorations conducted in 1973 (CH2M, 1974), 1986, 1989 and 1990 (Century West Engineering, 1989; 1990), and 1995 (CH2M, 1995) have been performed in the vicinity of the SCTP (CH2M, 1995). An exploration was completed in 1974 along the alignment of the existing outfall pipeline (CH2M, 1974). Two borings completed as part of the 1995 CH2M exploration were conducted within the Columbia River beyond the end of the existing outfall diffuser.

The mapped geologic unites are: silt and clay facies of Columbia River floodplain alluvium deposits (Qcf), sand facies of Columbia River floodplain alluvium deposits (Qcc), sand and silt facies of cataclysmic flood deposits (Qfs), and conglomerate member of Troutdale Formation (Ttfc).

A detailed discussion of the geotechnical field investigation and laboratory testing program, along with boring logs, laboratory test data, and a summary of the findings from the current geotechnical exploration is provided in the *Columbia River Outfall and Effluent Pipeline Project Draft Geotechnical Data Report* (Geotechnical Data Report) that is provided in Appendix F (CH2M, 2017c). Summaries of previous geotechnical explorations along with relevant boring logs and laboratory test data from those explorations are also provided in the Geotechnical Data Report provided in Appendix F.

- NOTES**
1. This drawing presents the results of a multi beam bathymetric survey conducted by Solmar Hydro, Inc.
 2. Date of Survey: July 22 and July 29, 2015.
 3. Horizontal Datum: North American Datum of 1983/91, State Plane Coordinate System, Washington South Zone, US Survey Feet.
 4. Vertical Datum: North American Vertical Datum 1988 (NADV88), Feet.
 5. Contour Interval: 1 foot.
 6. Horizontal positions for navigation and data collection were determined by using an Applanix POS/MV 320 operating in Real Time Kinematic (RTK) mode.
 7. Water surface elevations were derived using RTK GPS, WGS 84 Ellipsoid and the Geoid 2009 model.
 8. Bathymetric data was collected using an R2Sonic 2024 multibeam echosounder operating at 400 kHz.
 9. Singlebeam bathymetric data was collected using an Odom CV100 echosounder operating at 3 degrees, 200kHz.
 10. An AML Oceanographic SV Plus was used for water column sound velocity corrections.
 11. Survey data is represented at a 1.0 foot grid resolution.
 12. This bathymetric survey is representative of the condition of the bottom at the time of the survey. The condition of the bottom may change at any time after the date of this survey.
 13. Bathymetric data was collected in accordance with the U.S. Army Corps of Engineers hydrographic manual EM-1110-2-1003 (11/2013).
 14. Photogrammetry provided by the Oregon Imagery Explorer and is for reference only.

CONTROL USED
 GPS Base Station
 Point Number: 300
 E: 1064429.04
 N: 153674.00
 Elev: 24.43



SBE Survey Areas
 and Vessel Tracklines

GPS Base Station
 Point Number: 300
 E: 1064429.04
 N: 153674.00
 Elev: 24.43

APPROVED BY: M. Stecher
 CHECKED BY: M. Stecher
 SCALE: 1" = 150'
 DATE: August 17, 2015



**COLUMBIA RIVER BATHYMETRIC SURVEY
 SALMON CREEK WWTP
 OUTFALL REPLACEMENT PROJECT**

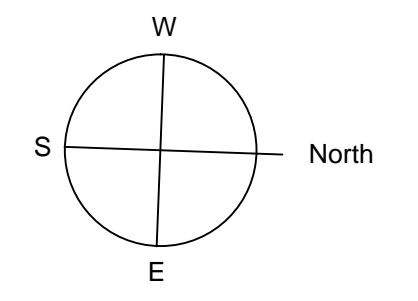
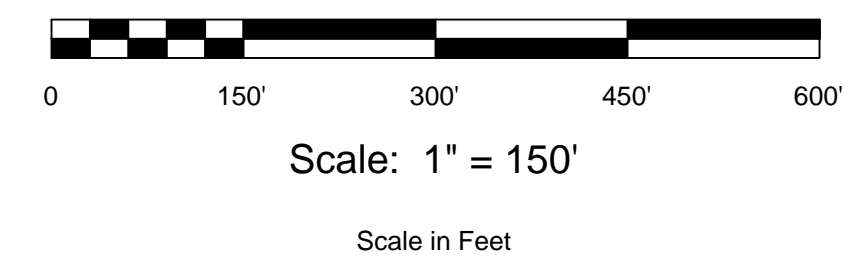
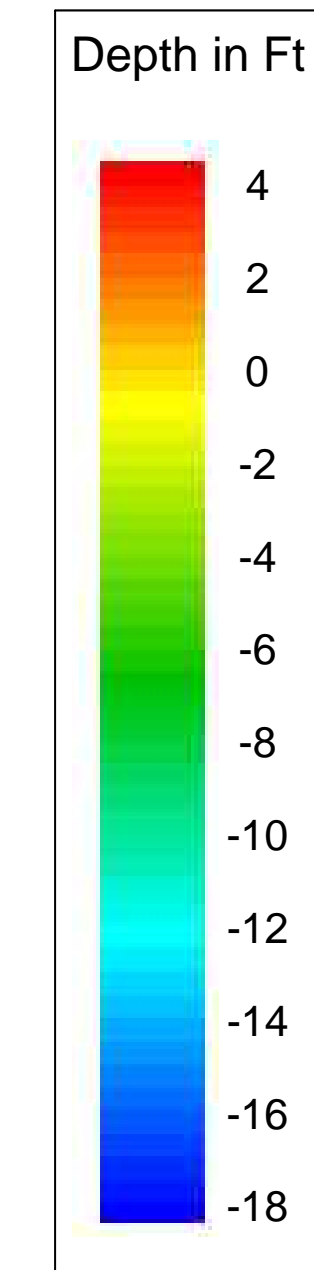
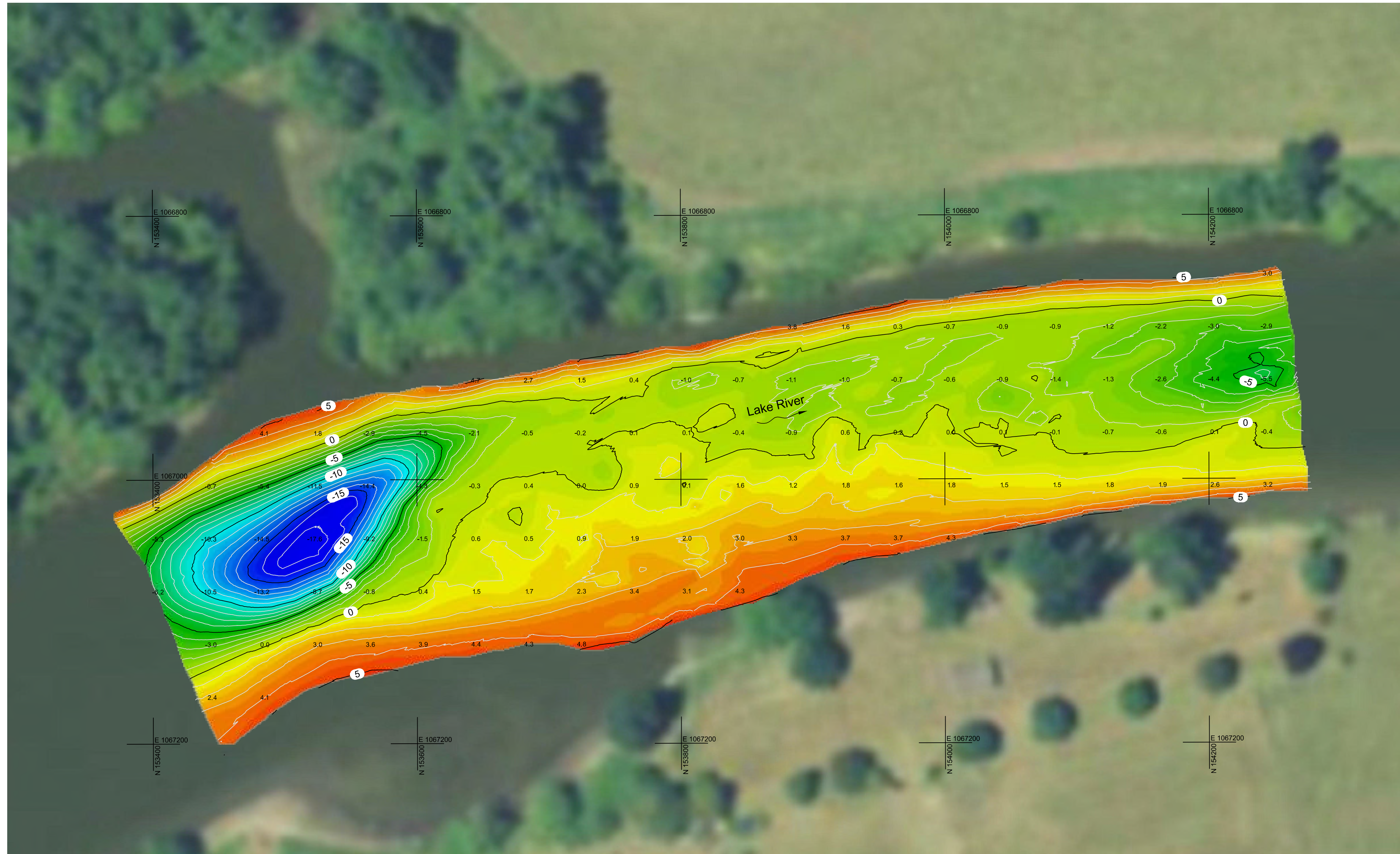
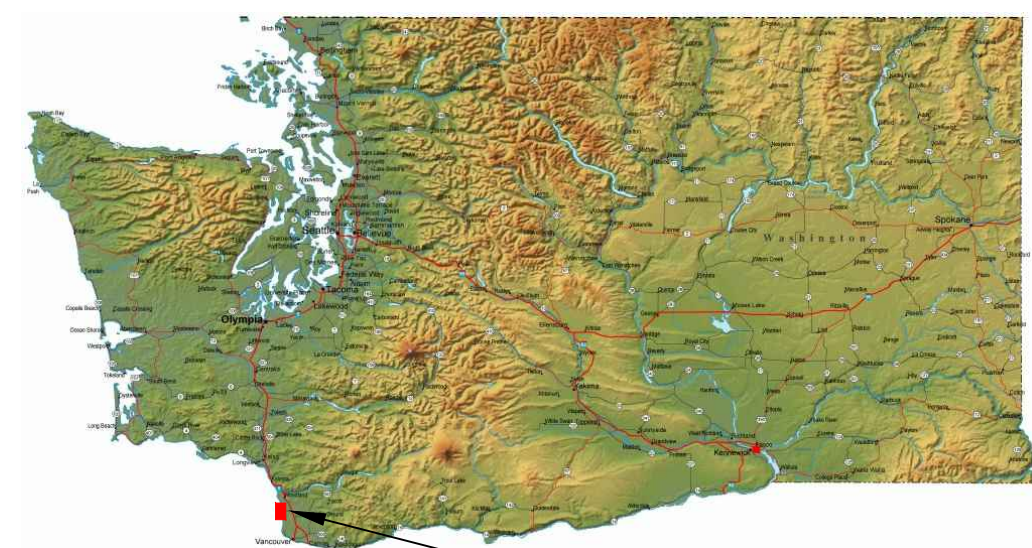


Figure 2-13

LAKE RIVER SURVEY



SALMON CREEK SURVEY



NOTES

1. This drawing presents the results of a multi beam bathymetric survey conducted by Solmar Hydro, Inc.
2. Date of Survey: July 29, 2015.
3. Horizontal Datum: North American Datum of 1983/91, State Plane Coordinate System, Washington South Zone, US Survey Feet.
4. Vertical Datum: North American Vertical Datum 1988 (NAVD88), Feet.
5. Contour Interval: 1 foot.
6. Horizontal positions for navigation and data collection were determined by using an Applanix POS/MV 320 operating in Real Time Kinematic (RTK) mode.
7. Water surface elevations were derived using RTK GPS, WGS 84 Ellipsoid and the Geoid 2009 model.
8. Singlebeam bathymetric data was collected using an Odom CV100 echosounder operating at 3 degrees, 200kHz.
9. An AML Oceanographic SV Plus was used for water column sound velocity corrections.
10. This bathymetric survey is representative of the condition of the bottom at the time of the survey. The condition of the bottom may change at any time after the date of this survey.
11. Bathymetric data was collected in accordance with the U.S. Army Corps of Engineers hydrographic manual EM-1110-2-1003 (11/2013).
12. Photogrammetry provided by the Oregon Imagery Explorer and is for reference only.

CONTROL USED

GPS Base Station
 Point Number: 300
 E: 1064429.04
 N: 153674.00
 Elev: 24.43

**LAKE RIVER AND SALMON CREEK
 SINGLEBEAM BATHYMETRIC SURVEYS
 SALMON CREEK WWTP
 OUTFALL REPLACEMENT PROJECT**

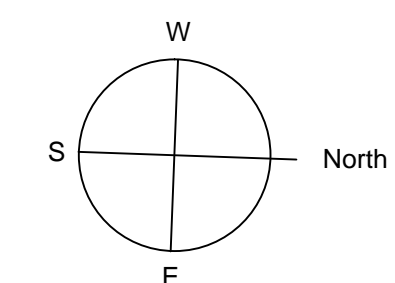
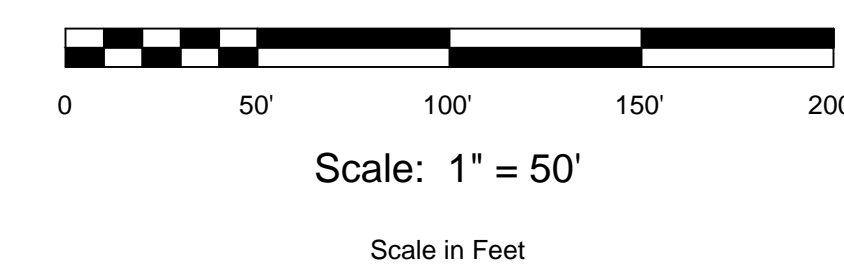


Figure 2-14

APPROVED BY: M. Stecher

CHECKED BY: M. Stecher

SCALE: 1" = 50'

DATE: August 17, 2015



Future Conditions

3.1 Flow Characteristics

Existing and projected effluent flows defined in Table 3-1 are documented in the Ecology-approved 2004 *Salmon Creek Wastewater Management System Wastewater Facilities Plan/General Sewer Plan* (2004 Facilities Plan) (CH2M, 2004b), 2013 Facilities Plan (CH2M, 2013), and *Draft Clark Regional Wastewater District Comprehensive General Sewer Plan Update* (BHC, 2016) that will be finalized and reviewed by Ecology in 2018. The average annual flows (AAF) and peak hourly flows (PHF) were defined for 2016, 2036, buildout, and 2066. PHFs include two scenarios: one set of attenuated flows where the Battle Ground equalization basin is in use and another set of non-attenuated flows where the Battle Ground equalization basin is offline.

Table 3-1. Projected Peak Hourly Effluent Flows

Year	Peak Hourly Flow with Battle Ground Equalization Basin (mgd)	Peak Hourly Flow without Battle Ground Equalization Basin (mgd)
2016	19	22 ^a
2036	38	44
2048	47	55 ^a
2066	62	72 ^{a, b}

Source: *Clark Regional Wastewater District Comprehensive General Sewer Plan Update* (BHC, 2016).

^a Extrapolated flows using the ratio of peak hourly flows with and without Battle Ground Equalization Basin in 2036.

^b Ultimate flow projection from Table 3-11 of 2004 Facilities Plan (CH2M, 2004b).

Dry season (May through October) and wet season (November through April) effluent flows (existing and projected stages, and buildout flows) are summarized in Table 3-2; these effluent flows have been applied in the modeling analyses for outfall diffuser design. These effluent flows are based on effluent monitoring data provided by the District and the Ecology-approved 2013 Facilities Plan, and these flows align with the PHF defined in Table 3-1 and the draft *Clark Regional Wastewater District Comprehensive General Sewer Plan Update* (BHC, 2016).

Table 3-2. Salmon Creek Treatment Plant Current, Projected Stages, and Projected Buildout Effluent Flow Statistics Used in Design Modeling

Flow Condition	MMDWF (mgd)	MDDWF (mgd)	MMWWF (mgd)	MDWWF (mgd)	AA (mgd)
Current (2016)	8.07	10.01	10.78	14.81	7.41
Projected (2025)	14.82	18.92	19.36	25.82	14.87
Projected (2040)	20.30	25.93	26.53	35.38	20.10
Projected (Buildout)	29.21	37.31	38.17	50.90	28.92

AA = average annual; MDDWF = maximum day dry weather flow; MDWWF = maximum day wet weather flow; MMDWF = maximum month dry weather flow; MMWWF = maximum month wet weather flow.

3.2 Wastewater Treatment and Effluent Characteristics

3.2.1 Wastewater Treatment

No changes are proposed to the SCTP wastewater process, and no changes to effluent characteristics are proposed as a result of the improvements proposed under this Engineering Report. The plant operates under the NPDES permit issued by Ecology. SCTP operates preliminary treatment, primary treatment, conventional activated sludge secondary treatment, ultraviolet (UV) disinfection of effluent, anaerobic digestion, and belt press dewatering of digested biosolids. The treatment process is described in the Ecology-approved 2004 Facilities Plan, and the 2013 Facilities Plan.

3.2.2 Effluent Chemical Characteristics

The SCTP wastewater chemical characteristics data have been assembled for use in the reasonable potential analysis (RPA) developed later in this section. Effluent ammonia, pH, hardness, metals, and priority pollutants data are compiled in Tables G-1 and G-2 in Appendix G of this report. Effluent metals and priority pollutants data are provided for the period of January 2011 through December 2015, and effluent ammonia data for June 2010 through July 2015. These effluent data were used to represent the maximum probable concentrations discharged, in Ecology's RPA spreadsheets described in the Permit Writer's Manual (Ecology, 2015a) and in accordance with the *Technical Support Document for Water Quality-based Toxics Control* (Technical Support Document) (EPA, 1991). The SCTP effluent is disinfected using a UV system, and no total residual chlorine is present in the effluent; therefore, it is not included in effluent monitoring.

3.3 Water Quality Standards and Design Dilutions

Key elements of Washington's water quality standards (WAC 173-201A) impact the design of outfall improvements for the SCTP and these are reviewed in this section for the development of the design criteria. Key elements of the water quality standards that can impact the design and permitting include existing water quality impairment (that is, 303(d) listing and total maximum daily loads [TMDLs]), compliance with water quality chemical criteria and temperature standards, effluent toxicity to aquatic organisms, and anti-degradation review. These key elements are discussed in this section and further reviewed after the preferred outfall improvement options are identified in Section 4.4.

A detailed evaluation of dilution requirements for the SCTP effluent was developed to define dilutions required to meet Washington's water quality standards. This evaluation is developed to identify the effluent constituents that require the greatest dilution to meet the water quality standards, and these will represent the target design dilutions or minimum design dilutions for the outfall improvements and diffuser. An evaluation of temperature compliance for the SCTP outfall improvements is presented in Section 4.4, after the preferred outfall improvement option is selected and identified.

3.3.1 303(d) Listing and Total Maximum Daily Loads

In accordance with Section 303(d) of the federal Clean Water Act, Ecology prepares an assessment of the state waters conditions and compliance with standards every 3 years. Ecology is required to identify water bodies in Washington that do not meet water quality standards, and these are placed on Ecology's proposed 303(d) list. Once developed, the state assessment is subject to review, revision, and approval by EPA Region 10. A 303(d) listing means that some monitoring data in the last 10 to 25 years exceeded the state standards that protect the most sensitive beneficial uses of the water. Depending on the classification level (Categories 1 to 5), the action required ranges from none, to continued monitoring (Categories 2 to 4), to development of a technical study and implementation plan for pollution control targets to improve water quality (Category 5). A Category 5 listing necessitates

development of a TMDL study and eventual waste load allocations to point and non-point source contributors to the violation—unless subsequent detailed water quality data negate the Category 5 listing. A Category 5 listing of a parameter also means that existing dischargers may not contribute to the degradation of the water quality (outside of a defined mixing zone region).

In 2016, EPA approved Ecology’s 2015 Integrated Report Assessment Database and 303(d) List. The following parameters were listed for the lower Columbia River reach that extends from the mouth of the Willamette River at RM 99 to the mouth of the Lewis River at RM 87.5 and includes the SCTP outfall location at RM 96 near the middle of the reach:

- Temperature: 20°C as 1-day maximum (with no temperature increase of greater than 0.3°C for single source of 1.1°C for all sources combined) to protect fish rearing and spawning.
- Dissolved Oxygen: 8.0 mg/L as a 1-day minimum and dissolved oxygen to exceed 90 percent saturation to protect fish rearing, spawning, and migration.
- Bacteria: fecal coliform bacteria not to exceed geometric mean of 100 organisms per 100 milliliters and not more than 10 percent of samples with values greater than 200 organisms per 100 milliliters to protect primary contact recreation.

Regarding temperature, the Columbia and Snake River have been on Ecology’s 303(d) list for temperature impairments for decades. In 2003, EPA Region 10 released temperature guidance for Pacific Northwest states and EPA published the Columbia/Snake Rivers Temperature TMDL, Preliminary Draft. The EPA’s preliminary draft temperature TMDL for the Columbia River included a draft total heat load allocation of 926.3 megawatts for the group of dischargers between RM 112 and RM 95 (including SCTP, two Vancouver wastewater treatment plants (WWTPs), City of Portland Columbia Boulevard WWTP, and other smaller discharge sources). The preliminary draft TMDL also included a point source maximum temperature increase of 0.026°C in the river, which is equivalent to the current state water quality standard of 0.3°C maximum allowable increase at a mixing zone boundary. The draft TMDL has not advanced, and, in 2016, two groups filed notice of intent to sue EPA for this inaction.

To address concerns over Columbia River dissolved oxygen and pH compliance with state water quality standards, Columbia River sampling and chemical analyses were developed for the design and permitting of the replacement outfall and diffuser. Before data collections, the QAPP (CH2M, 2015) was prepared for the Alliance and submitted to Ecology for review and approval. The QAPP defines the project objectives, approach, procedures, quality control/quality assurance requirements, data review, and data reporting for the water quality sampling of the Columbia River. The sampling process design defined in the QAPP included: (1) collecting background Columbia River water samples at a site upstream of the SCTP outfall (during ebb tide) monthly during a 4 month period from July through October 2015, (2) conducting water quality measurements in vertical water column profiles at five Columbia River sampling sites during ebb and flood tides from July through October 2015, and (3) collecting continuous in situ water quality measurements at mid-water depth using an instrument on an anchored cable array in August, September, and October 2015.

The extensive 2015 water quality measurements in the Columbia River near RM 96 yielded no exceedances of Washington’s surface water quality standards for pH, dissolved oxygen, and turbidity. All river pH values were within the freshwater criteria range of 6.5 to 8.5. All river dissolved oxygen values were greater than the freshwater criteria of 8.0 mg/L for salmonid spawning, rearing, and migration; and all dissolved oxygen saturation values exceeded the 90 percent threshold. All river turbidity values were within the turbidity criteria limits. River temperatures exceeded 20°C because of natural conditions in the river.

In addition, the middle reach of Lake River (where the effluent pipeline will be buried) has the following parameters listed on the 2015 303(d) list as Category 5 for fish tissue samples based on samples of carp and suckers: Toxics in fish tissue: 4,4’ DDE; Dieldrin; Dioxin; and PCBs.

This listing for toxics in fish tissue in Lake River will not be affected by this project.

There are no 303(d) listed toxic substances in the water or sediments in the vicinity of the SCTP discharge to the Columbia River. The District completed a detailed sediment chemistry evaluation for the sediments in the immediate vicinity of the existing SCTP outfall diffuser in 2016, and the study findings show no chemical impacts (refer to Appendix E). Effluent sampling and analyses for metals and priority pollutants are currently conducted quarterly. RPAs of compliance with water quality criteria have been developed for the SCTP based on existing effluent monitoring data and background river data. These are discussed in the following section.

3.3.2 Target Design Dilutions for Effluent Chemicals

RPAs have been developed to identify target design dilutions needed at the acute zone boundary (AZB) and at the chronic mixing zone boundary (MZB) for the SCTP effluent discharge to comply with Washington water quality standards (WAC 173-201A). The discharge needs to comply with acute water quality criteria for the protection of aquatic life at the AZB; and comply with chronic water quality criteria for the protection of aquatic life and water quality criteria for the protection of human health at the chronic mixing zone boundary MZB. These RPAs have been developed using the procedures in the Permit Writer's Manual (Ecology, 2015), using Ecology's RPA spreadsheets, and in accordance with the Technical Support Document (EPA, 1991). The objective of these analyses is to identify the dilution factors required for the SCTP effluent discharge to meet acute and chronic water quality criteria for the protection of aquatic organisms and human health.

The evaluations of discharge compliance requirements have included effluent ammonia, metals, and organics chemicals data. Effluent ammonia, metals, hardness, and priority pollutant organics data are compiled in Tables G-1 and G-2 in Appendix G of this report. Effluent metals and priority pollutants data are provided for January 2011 through December 2015, and effluent ammonia data for June 2010 through July 2015. These effluent data were used to represent the maximum probable concentrations discharged. Background Columbia River chemistry data were collected during four months in 2015 under low river flow conditions. These background river chemistry data are summarized in Appendix C-5.

3.3.2.1 Ammonia

Maximum effluent ammonia dry and wet season concentrations data have been applied in the ammonia evaluation of dilutions required for SCTP effluent compliance with both existing Washington water quality criteria for ammonia and with EPA's 2013 freshwater ammonia criteria. EPA published *Aquatic Life Ambient Water Quality Criteria for Ammonia – Freshwater 2013* in August 2013, and these updated federal water quality criteria have been developed and revised to include protection of mussels and salmon when they are present in the streams. Washington has not yet adopted these ammonia water quality criteria, but they are assumed to be incorporated into Washington water quality criteria for ammonia in the future.

The existing Washington ammonia criteria were amended in 2016, and Ecology cites EPA's 1986 Quality Criteria for Water as the basis for this amendment. Washington also adopted EPA's exposure duration approach for the ammonia criteria, applying a maximum 1-hour average concentration for acute criteria, and a maximum 30-day average concentration and a maximum 4-day average concentration for chronic criteria. The *Aquatic Life Ambient Water Quality Criteria for Ammonia – Freshwater 2013* (EPA, 2013) specifies a maximum 1-hour average concentration (acute criteria), a maximum rolling 30-day average concentration (chronic criteria), and a maximum 4-day average concentration within the rolling 30-day period. EPA's 2013 criteria have been calculated assuming both salmon and Unionid mussels are present near the discharge, the most conservative approach.

Parallel ammonia RPAs were developed based on the dry and wet season maximum effluent ammonia values and applying the Washington ammonia criteria and the EPA’s 2013 freshwater ammonia criteria. Table 3-3 presents the results of these ammonia RPAs. The results of these calculations show that the SCTP effluent discharge requires dilutions during dry and wet seasons of 4 (wet) to 9 (dry) at the AZB to meet Washington’s acute water quality criteria (1-hour average), and dilutions of 68 (dry) to 20 (wet) at the MZB to meet the chronic water quality criteria (30-day average) and dilutions of 27 (dry) to 8 (wet) at the MZB to meet the 4-day average chronic criterion, as depicted in the upper half of Table 3-3. Based on EPA’s 2013 freshwater ammonia criteria, the SCTP effluent discharge requires dilutions of 15 (dry) to 5 (wet) at the AZB to meet the acute water quality criteria (1-hour average) and dilutions of 65 (dry) to 20 (wet) at the MZB to meet chronic water quality criteria (30-day rolling average) and dilutions of 26 (dry) to 8 (wet) at the MZB to meet the 4-day average chronic criterion, as depicted in the lower half of Table 3-3. These results show that dilution requirements for ammonia with the 2013 EPA ammonia criteria are equal or slightly greater than those currently required for the acute and chronic ammonia criteria compliance.

Table 3-3. Evaluation of SCTP Discharge Compliance with Existing Washington Ammonia Criteria and with EPA 2013 Ammonia Water Quality Criteria and Definition of Target Design Dilutions for the SCTP Discharge to the Columbia River
Engineering Report for the Phase 5A Project—Columbia River Outfall and Effluent Pipeline

Parameter	Water Quality Criteria ^a		Number of Samples	Maximum Effluent Concentration (mg N/L) ^c	Multiplying Factor (99% Confidence Limit and 95% Probability) ^d	Background River Concentration (90th %) (mg N/L)	Minimum Dilution Needed to Meet Acute Water Quality Criteria at AZB	Minimum Dilution Needed to Meet Chronic Criteria at MZB
	Acute Criteria (1-hour average) (mg/L) ^b	Chronic Criteria (30-day average/ 4-day average) (mg/L) ^b						
Existing Washington State Ammonia Water Quality Criteria								
Dry Season (May–October)	2.31	0.299 / 0.75	610	20.2	1.0	0.05	9	68/27
Wet Season (November–April)	2.31	0.473 / 1.18	560	9.4	1.0	0.05	4	20 / 8
EPA 2013 Ammonia Water Quality Criteria								
Dry Season (May–October)	1.3	0.31 / 0.78	610	20.2	1.0	0.05	15	65/26
Wet Season (November–April)	2.1	0.48 / 1.2	560	9.4	1.0	0.05	5	20 / 8

^a Freshwater acute & chronic criteria from Washington State Water Quality Criteria WAC 173-201A (Table 240(3), 2016). Acute and chronic criteria based on worst-case dry season maximum river temperature of 22.0°C and pH of 8.5, and worst-case wet season maximum river temperature of 15°C and pH of 8.5.

^b Freshwater acute criterion is a 1-hour average concentration not to be exceeded more than once every 3 years on the average; and chronic criteria are a 30-day rolling average concentration not to be exceeded more than once every 3 years on the average and a 4-day average concentration not to be exceeded more than once every 3 years on the average.

^c Ammonia based on effluent ammonia concentrations for SCTP (June 2010–December 2017).

^d The reasonable potential multiplying factor assumes a coefficient of variation of 0.6, based on guidance in Table 3-2 (p. 57) in the Technical Support Document (EPA, 1991).

^e Freshwater acute & chronic criteria from EPA August 2013 Revised Freshwater Ammonia Criteria. Acute and chronic criteria based on dry season maximum river temperature of 22.0°C and pH of 8.5, and wet season maximum river temperature of 15.0°C and pH of 8.5.

3.3.2.2 Metals and Organics

The evaluation of discharge compliance requirements for the SCTP effluent metals and organic chemical was developed using effluent chemistry data collected from 2011 through 2017. These effluent metals and organic chemical values were used to identify detected constituents and to select the maximum effluent concentrations to apply in the RPA for compliance with Washington water quality criteria (WAC 173-201A-240). Table 3-4 provides a summary evaluation of dilutions required for the SCTP effluent discharge of metals and organics to comply with Washington water quality criteria for the protection of aquatic life and for the protection of human health.

This discharge compliance evaluation for SCTP effluent shows that very limited dilutions are required for compliance with acute and chronic water quality criteria for the protection of aquatic life (Table 3-4). The SCTP discharge can meet acute and chronic aquatic life water quality criteria with a minimum dilution of 1 to 7 (copper) at the AZB (acute) and a minimum dilution of 1 to 11 (copper) at the MZB (chronic). The dilution required at the AZB for cyanide is based on a detection limit and not actual measured value. The dilution required at the MZB for heptachlor (pesticide) is based on a single low detected value in 2012, and subsequent effluent analyses have not detected this constituent.

The furthest right column in Table 3-4 provides a summary evaluation of dilutions required for the SCTP effluent discharge to comply with Washington water quality criteria for the protection of human health. No effluent metal or organic constituent except bis(2-ethylhexyl)phthalate is routinely detected and requires dilution or other measures to comply with water quality criteria for the protection of human health. The plasticizer, bis(2-ethylhexyl)phthalate, is a ubiquitous constituent in municipal effluents since it is used in cosmetics as well as plastics in households. The maximum detected concentration in six SCTP effluent samples was 26.8 micrograms per liter ($\mu\text{g}/\text{L}$), and based on the very low human health criteria for consumption of water and organisms of $0.045 \mu\text{g}/\text{L}$ (per EPA's *Partial Approval/Partial Disapproval of Washington's Human Health Water Quality Criteria and Implementation Tools*, 2016), the resulting required dilution of 556 is not attainable. The District and other municipal dischargers in Washington will need to work with Ecology to develop source control measures for phthalates in wastewater since the SCTP and other comparable facilities cannot efficiently remove or destroy this compound in wastewater.

The maximum projected effluent arsenic concentration is $1.85 \mu\text{g}/\text{L}$ (based on 26 effluent samples and the human health reasonable potential multiplier of 0.55), and the median Columbia River background arsenic concentration is $1.24 \mu\text{g}/\text{L}$. The background river concentration and projected maximum effluent concentration are two orders of magnitude greater than the human health criteria for consumption of water and organisms of $0.018 \mu\text{g}/\text{L}$ (EPA, 2016). Because there are background concentrations of arsenic (due to erosion of basalt in the Columbia River) and treatment is infeasible, Ecology may need to develop a state-wide variance for arsenic. The only other detected organic chemicals that show required dilutions at the MZB are beta-BHC and heptachlor (pesticides); these were each detected once in 2012, but subsequent effluent analyses in 2013 through 2017 have not detected them. Continued annual effluent monitoring for pesticides is appropriate, and, if another detection occurs, then the Alliance should develop a public information campaign and pesticide disposal program for sewer users.

It is clear from these metals and organics RPA results that effluent ammonia concentrations determine the target dilutions required for the outfall diffuser design for this project.

Table 3-4. Evaluation of Dilution Requirements for Water Quality Compliance for the Salmon Creek Treatment Plant Outfall 001 Discharge to the Columbia River
Engineering Report for the Phase 5A Project—Columbia River Outfall and Effluent Pipeline

Parameter	Water Quality Criteria ^a			No. of Effluent Samples	Maximum Effluent Concentration (2011-2017) (µg/L)	Reasonable Potential Multiplying Factor (95% Confidence Limit & 95% Probability) ^d	Human Health Reasonable Potential Multiplying Factor	Upper 90th-% Background River Concentration (µg/L) ^e	Median Background River Concentration (µg/L) ^e	Aquatic Life		Human Health
	Aquatic Life		2016 Final CWA-Effective Human Health Criteria ^g (µg/L)							Minimum Dilution to Meet WQ Criteria at Acute Zone Boundary ^f	Minimum Dilution to Meet WQ Criteria at Mixing Zone Boundary ^f	Minimum Dilution to Meet HH-WQ Criteria at Mixing Zone Boundary ^f
	Acute (µg/L) ^b	Chronic (µg/L) ^c										
Antimony	--	--	6	26	0.22	1.26	0.55	0.1	0.1	--	--	0
Arsenic ⁱ	360	190	0.018	26	1.85	1.26	0.55	1.24	1.24	0	0	i
Cadmium	2.1	0.7	--	26	0.03 1/2 DL	1.26	--	0.1	0.1	0	0	--
Chromium (+3)	336	112	--	26	0.56	1.26	--	0.44	0.44	0	0	--
Copper	10.3	7.0	1300	26	59.6	1.26	0.55	0.8	0.8	7	11	0
Lead	36.1	1.4	--	26	0.83	1.26	--	0.13	0.13	0	1	--
Mercury	2.1	0.012	0.14	12	0.0025	1.63	0.70	0.0068	0.0068	0	1	0
Nickel	904.5	97.7	80	26	1.6	1.26	0.55	0.83	0.83	0	0	0
Selenium	20	5.0	60	26	0.23	1.26	0.55	0.5	0.5	0	0	0
Silver	1.4	--	--	26	0.03	1.26	--	0.01	0.01	0	--	--
Thallium	--	--	1.7	26	0.05 1/2 DL	1.26	0.55	0.01	0.01	--	--	0
Zinc	73.1	64.9	1000	26	60.0	1.26	0.55	4.5	4.5	1	1	0
Cyanide	1.0	5.2	9	6	5.0 1/2 DL	2.14	0.93	0.0	0	11	2	1
Bis(2-Ethylhexyl)Phthlate	--	--	0.045	6	26.8	2.14	0.93	0.0	0	--	--	556
1,2-Dichloroethane	--	--	8.9	6	0.5 1/2 DL	2.14	0.93	0.0	0	--	--	0.1
Dichlorobromomethane	--	--	0.73	6	0.5 1/2 DL	2.14	0.93	0.0	0	--	--	1
Benzene	--	--	0.44	6	0.5 1/2 DL	2.14	0.93	0.0	0	--	--	1
beta-BHC (pesticide)			0.0013	6	0.02 j	2.14	0.93	0.0	0	--	--	14
Heptachlor (pesticide)	0.53	0.0036	0.00000034	6	0.019 j	2.14	0.93	0.0	0	0.1	11	52172
Chloroform	--	--	100	6	0.5 1/2 DL	2.14	0.93	0.0	0	--	--	0
Napthalene	--	--	--	6	0.2 1/2 DL	2.14	0.93	0.0	0	--	--	--
Toluene	--	--	72	6	1.1	2.14	0.93	0.0	0	--	--	0
Phenol	--	--	9000	6	10 1/2 DL	2.14	0.93	0.0	0	--	--	0
Ammonia 2011-17 (Dry Season) ^h	2310	299	--	610	20200	1.0		50	30	9	68	--
Ammonia 2011-17 (Wet Season) ^h	2310	473	--	560	9400	1.0		50	30	4	20	--

a Freshwater acute & chronic criteria from Chapter 173-201A-240 WAC (2016) Water Quality Standards for Washington. Mixed river and effluent hardness of 58.5 mg/L (acute) and 55.6 mg/L (chronic).

b The freshwater acute criteria is a 1-hour average concentration not to be exceeded more than once every 3 years on the average, with the exception of silver, which is an instantaneous concentration not to be exceeded at any time.

c The freshwater chronic criteria is a 4-day average concentration not to be exceeded more than once every 3 years on the average.

d The reasonable potential multiplying factor assumes a coefficient of variation of 0.6, based on guidance on Table 3-2 (p.54) in the Technical Support Document (EPA, 1991) and Ecology's RPA spreadsheet.

e Background receiving water analytical data collected during ebb tide conditions in August to October 2015 near Columbia River RM 96. These background river data are based on clean sampling and low detection analytical methods.

f The acute zone boundary for the outfall is point of acute aquatic life criteria compliance and the chronic mixing zone boundary is the point of chronic aquatic life and human health criteria compliance.

g The revised water quality criteria for human health (HHC) were made effective by EPA on 12/28/2016. The lowest HHC - water & organisms or organisms only - is presented in this table for compliance assessment.

h Total ammonia as N. Criteria calculated using worst-case receiving water pH of 8.5 and temperature of 22.0°C (summer-dry season; May-Oct) and worst-case pH of 8.5 and temperature of 15°C (winter- wet season; Nov-April).

i Note that the current HHC for arsenic is lower than the concentration in the Columbia River and therefore not attainable.

j Single detected values reported from priority pollutant sample collected in 2012 and no other detected values in 2011, 2013, and 2014 - 2017 samples.

Alternatives Analysis

4.1 Design Criteria

The design criteria used in the alternatives analysis of the new effluent pipeline and outfall project are described in the subsections below.

4.1.1 Effluent Flows

Effluent flows used for the outfall design were defined in Section 3.1 and by reference to the *Draft Clark Regional Wastewater District Comprehensive General Sewer Plan Update* (BHC, 2016). The design flow criterion used for the effluent pipeline and outfall design is 72 mgd, which corresponds to the peak hourly wet weather flow for 2066 flow conditions with the Battle Ground equalization basin offline. The design criterion for the Phase 5 pump station improvements is 34 mgd. The design criteria for the diffuser design are the dry season (May through October) and wet season (November through April) effluent flows (existing and projected stages, and buildout flows) summarized in Table 3-2.

4.1.2 Pipeline Route Establishment Criteria

Several pipeline route establishment design criteria are considered for the new effluent pipeline:

- **Parallel Alignment.** To minimize disruption to current landowners, one of the main criteria in establishing the new effluent pipeline route is to maintain a parallel alignment to the existing outfall where feasible. This is important for land owners of Curtis Lake Ranch and New Columbia Garden Company, Inc., properties where long stretches of the effluent pipe will be buried.
- **Separation and Offset Requirements.** In River crossing areas, it is important to allow for enough separation from the existing pipe to avoid disturbing the existing pipe while maintaining distance from deeper areas observed from the bathymetric surveys for Salmon Creek and Lake River. The alignment considerations also include meeting necessary offset and casing requirements set forth by BNSF.
- **Use of Negotiated Easements.** Working within currently negotiated easements is a priority in establishing the pipeline alignment. This is especially important for properties where multiple owners are involved, such as owners of the Ashley Ridge Homeowners Association and Felida 26 acres. Avoiding new easement negotiations for permanent or temporary access is an important design criterion. New easement acquisitions will be required for DNR, BNSF Railway Company, Curtis Lake Ranch, and New Columbia Garden Company properties, but continued communication with owners of these properties has helped to identify alignment preferences, which are being considered during development of design criteria.
- **Utilities.** Several utilities are present along the existing effluent pipeline alignment including the BNSF railroad, a regional communications line, a petroleum pipeline, and an overhead telephone line. Avoidance requirements set forth by utility companies for overhead and underground utility crossings will be accounted for in the establishment of the pipeline route.
- **Access.** Pipeline route evaluation takes into consideration construction access to the various construction areas and future access for pipeline O&M. Access to the various project areas is limited by the presence of BNSF railroad, Salmon Creek, and Lake River, but is possible via existing roads and crossings. Access may also be limited by wetlands and presence of cultural resources. Several main access options will be considered in the evaluation of the establishment of the pipeline route. They include the following:

- **BNSF Railroad Crossings.** There are two existing railroad undercrossings for employee vehicles and minor equipment access. The first crossing consists of a railroad bridge undercrossing, has a clearance of approximately 14 feet, and is located between the SCTP and the east side of Salmon Creek. The second one is located on Curtis Lake Ranch property, consists of a tunnel undercrossing, and has a clearance of 10 feet 8 inches. Curtis Lake Ranch also includes an at grade crossing for larger truck access. The railroad is a major corridor between Portland and Seattle with a high frequency of trains (up to several per hour) requiring a flagger for any at grade road crossing needs; BNSF may require improvements at the crossings (to be determined).
- **Lake River and Salmon Creek.** Lake River and Salmon Creek are considered navigable by the U.S. Coast Guard (USCG). They could be used to transport materials, equipment, or personnel to the site by barge. These waterways are unbridged and are barriers to terrestrial access between properties.
- **Lower River Road.** Alliance maintains access through an existing easement on Lower River Road, a paved, recently vacated county road that belongs to New Columbia Garden Company. This road will be a key avenue of access for construction of the pipeline and outfall for the area between the Columbia River and Lake River.
- **Soil and Groundwater Conditions.** Field investigations have evaluated soil conditions and groundwater depth information through borings and installation of piezometers. Some of the groundwater depth data will continue to be collected in 2018. Although soil and groundwater conditions will not drive the vertical alignment of the route, they will impact the depth of burial in certain locations, the timing of construction, and dictate the need for dewatering. For trenchless construction, soil and groundwater conditions are also important design criteria for the type of trenchless method used. Strategically placed trench plugs will be needed to prevent a French drain effect.
- **Wetlands and Cultural Resources.** Several wetlands and cultural resource sites have been identified during the field investigations on the Curtis Lake Ranch, New Columbia Garden Company, and Alliance properties and easements in the vicinity of the alignment. Staging areas and construction accesses will avoid wetlands, and the effluent pipeline trench will minimize temporary wetland impacts, as practicable. Cultural resources sites will be avoided, as possible. All reasonable efforts will be taken to minimize impacts or exposure of archaeological properties, in consultation with applicable stewardship agencies.
- **Feasibility of Construction Methods and Trenchless Technology.** This will be considered especially where the route crosses the BNSF railroad, Salmon Creek, and Lake River in the establishment of the pipeline route.

4.1.3 Outfall Location and Diffuser Design Criteria

The design development for the new SCTP outfall and diffuser in the Columbia River requires consideration of physical forces, changing riverbed conditions, river stage elevations, discharge hydraulics and dilutions, and protection of the structures. The key objectives for the selection of the outfall route and diffuser location in the Columbia River and diffuser design criteria are as follows:

- Design outfall and diffuser to provide long-term hydraulic capacity required by the SCTP.
- Ensure adequate dilution of treated wastewater discharged into the Columbia River for projected effluent flows to meet Washington water quality standards, and locate to optimize transport of discharge plume without contacting shoreline for over 1/2 mile and to allow a large inshore region for salmon migration.

- Select the outfall diffuser site for bed-form stability and design the diffuser to address river bed-form dynamic variability at the diffuser site.
- Select diffuser site over 150 feet from nearest Columbia River navigation channel (subject to dredging).
- Design buried outfall pipe and diffuser in river to provide structural stability through the shoreline and offshore regions.

Design criteria for the Columbia River outfall and diffuser locations and the diffuser are summarized in the following items:

- **Hydraulic Requirements for Outfall Diffuser.** The hydraulic capacity of the outfall pipeline and diffuser section needs to avoid limitations to effluent peak flow discharges, avoid outfall pipe velocities exceeding 10 ft/sec, and avoid port discharge velocities exceeding 9 ft/sec under future effluent flows (except wet season maximum day). Outfall pipeline size, riser size, and diffuser port size need to be selected to meet these criteria and to avoid creating excessive head loss that adversely impacts effluent pumping requirements. The head loss for the diffuser risers and ports will be limited to 5 feet, to align with the hydraulic criteria and avoid additional pumping demands.

To meet the EPA redundancy requirements, the effluent pump station must be hydraulically designed to pass a peak-hour flow with the largest effluent pump out of service at the 100-year flood stage. Therefore, the initial pump replacements will be four equally-sized pumps with a firm capacity of 43.8 mgd peak-hour flow, which will give the effluent pump station enough capacity through SCTP Expansion Program Phase 5 (36 mgd peak-hour flow) and Phase 6 (43 mgd peak-hour flow).

- **Dilution Requirements for Outfall Diffuser.** The target minimum dilution requirements for the SCTP effluent discharge to meet Washington water quality chemical criteria and water quality standards have been developed in Section 3.3 of this report. The number of diffuser ports, port size, port spacing, and discharge depths need to be designed to provide the target minimum dilutions at the acute and chronic mixing zone boundaries in the river under critical river and effluent discharge conditions (as defined in the Permit Writer's Manual [Ecology, 2015a]) including buildout effluent flow—with a safety factor of 50 percent above the minimum required for aquatic life criteria. For SCTP effluent chemicals to meet human health criteria under all conditions, effluent monitoring and public education for source controls of some substances (i.e., pesticides) will be needed. Effluent source controls of phthalate organics (plasticizers) will require the coordinated efforts of the SCTP, Ecology, and other municipal dischargers because phthalates are ubiquitous in municipal effluents and not effectively treated in secondary treatment systems.
- **Structural Stability of River Outfall and Diffuser Pipe.** Develop the river outfall pipeline design depth of burial and support to provide structural stability for the design life of the system. The structural stability will be developed based on the geotechnical explorations, seismic calculations, and pipe structural analyses. The existing 30-inch-diameter, concrete-coated steel pipe is pile supported for a length of 345 feet, and the subsurface conditions in the river are sands. It is assumed that the replacement SCTP outfall pipeline and diffuser section will require some pile-supported section to resist lateral and vertical forces. In addition, ball joints will be evaluated for the river outfall pipe.
- **Columbia River Bedform.** The outfall diffuser needs to be located at sufficient depth and with sufficient length to achieve the dilution requirements for the SCTP effluent discharge to the river. The existing SCTP outfall is located near RM 95.9, approximately 150 feet south of the Willow Pile Dike. The Columbia River between RM 95.5 and RM 96.2 has a relatively broad nearshore shallow shelf (less than 10 to 15 feet water depth at low flow) that is affected by the nearshore pile dikes capturing and holding river sediments. Beyond the nearshore shelf, the riverbed slopes to a 40- to

50-foot depth (refer to Figure 4-1). The water depth of 40 to 45 feet beyond the slope has been identified as preferred for the new diffuser location. Detailed modeling and historical bedform evaluations have been prepared to assess the river bedform stability and range of sand wave heights in the preferred diffuser location (refer to Appendix D—Columbia River Bedform and Shoreline Technical Memorandums).

- Columbia Riverbank Erosion.** The Columbia River shoreline near the existing SCTP outfall has shown significant erosion in the last 20 years (refer to Figure 4-1) and this shoreline poses a risk of bank erosion to the new buried outfall pipeline into the river. Detailed evaluations of historical shoreline changes and sediment characterizations have been used to address the bank erosion risks (refer to Appendix D—Columbia River Bedform and Shoreline Technical Memorandums). The bank erosion risk will be mitigated by deep pipe burial and contingency armoring/pipe cover.

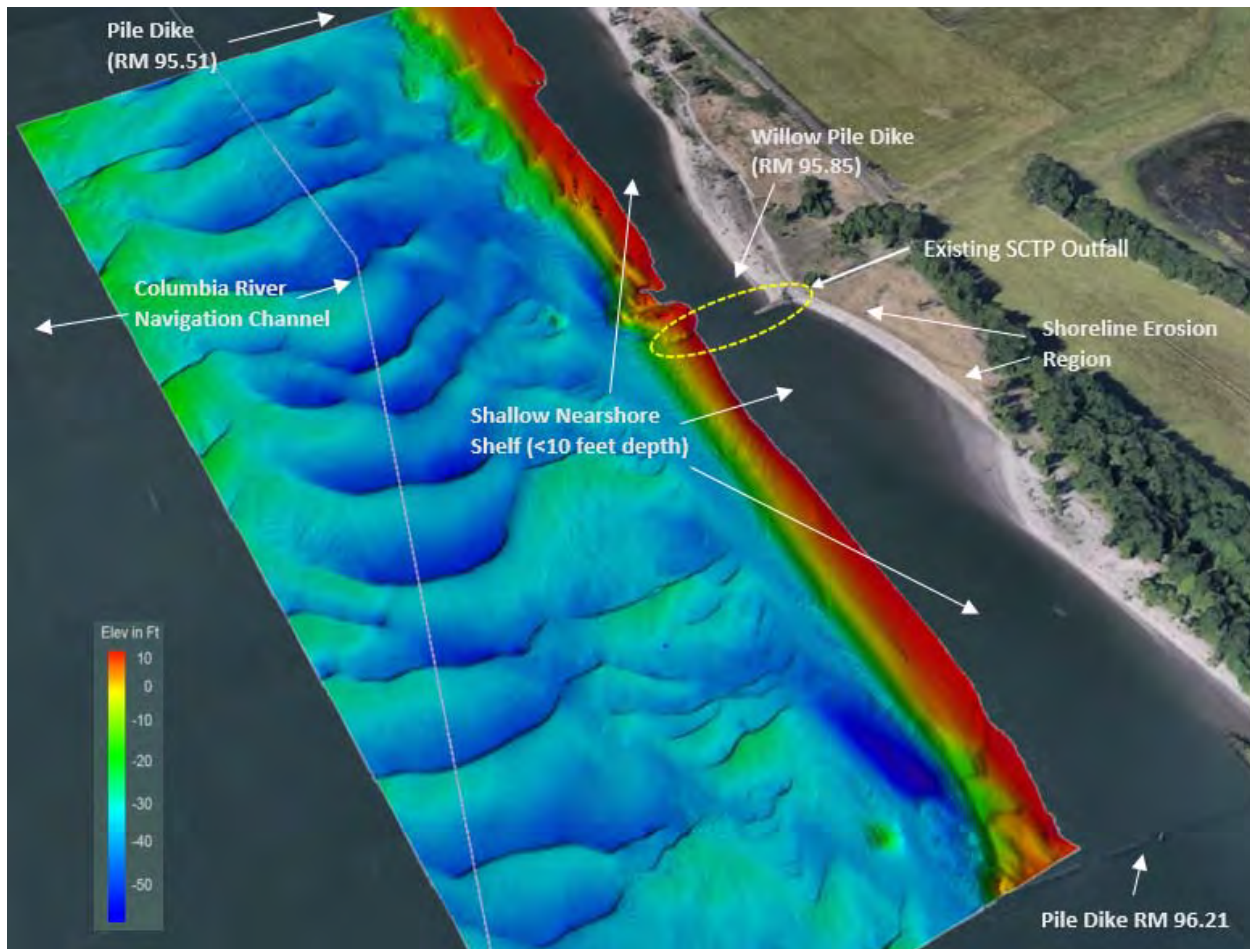


Figure 4-1. Overview of Columbia River Bathymetry Along Eastside of River Between RM 95.5 and RM 96.2
Engineering Report for the Phase 5A Project—Columbia River Outfall and Effluent Pipeline

4.1.4 System Hydraulics and Pump Station Considerations

The effluent from the SCTP can flow through the existing and new effluent pipeline and outfall by gravity. Depending on the Columbia River stage and the effluent flow volume, effluent pumping may be required. During 100-year flood river stage there is little difference between the effluent wet well water surface (elevation 25.68 feet, National Geodetic Vertical Datum of 1929 [NGVD29]), corresponding to the lead PUMP ON control elevation and the river elevation (25.6 feet, NGVD29). During this 100-year flood river stage condition, maximum gravity flow is limited to 3 mgd. Above this flow rate, effluent

pumping will be required. Figure 4-2 illustrates the relationship between river stage and gravity flow capacity. All flows above 36.7 mgd must be pumped regardless of river elevation.

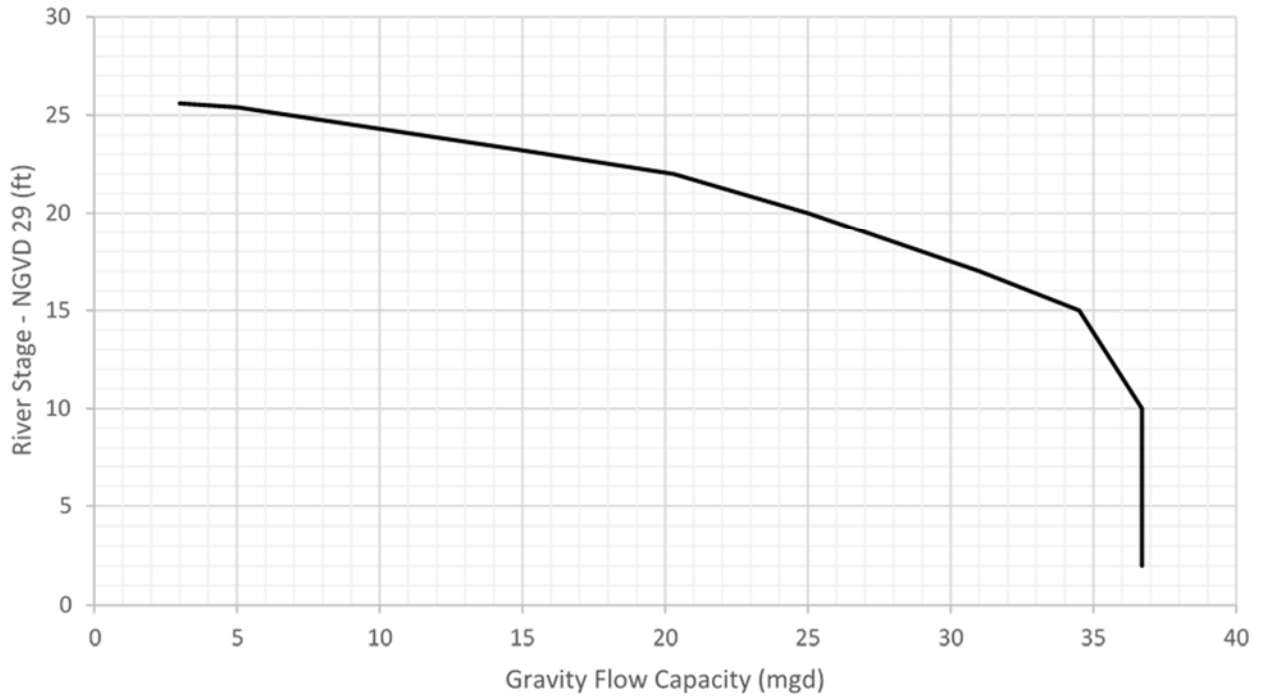


Figure 4-2. River Elevation versus Gravity Flow Capacity
Assumes effluent wet well hydraulic elevation = 25.68 feet
Engineering Report for the Phase 5A Project—Columbia River Outfall and Effluent Pipeline

During the Columbia River 100-year flood stage condition (elevation 25.6 feet), the maximum gravity flow possible is 3 mgd. This maximum gravity flow can be increased if the lead effluent PUMP ON level set point is raised. By upwardly adjusting the set point by 0.7 foot (elevation 26.3 feet), the gravity flow would be increased to approximately 6 mgd. This may be required to avoid cycling effluent pumps during low flow/high river stage scenarios.

Figure 4-3 illustrates the frequency of gravity effluent flow versus pumped effluent flow for each phased expansion. This figure also assumes that the effluent PUMP ON level is set at elevation 25.68 feet.

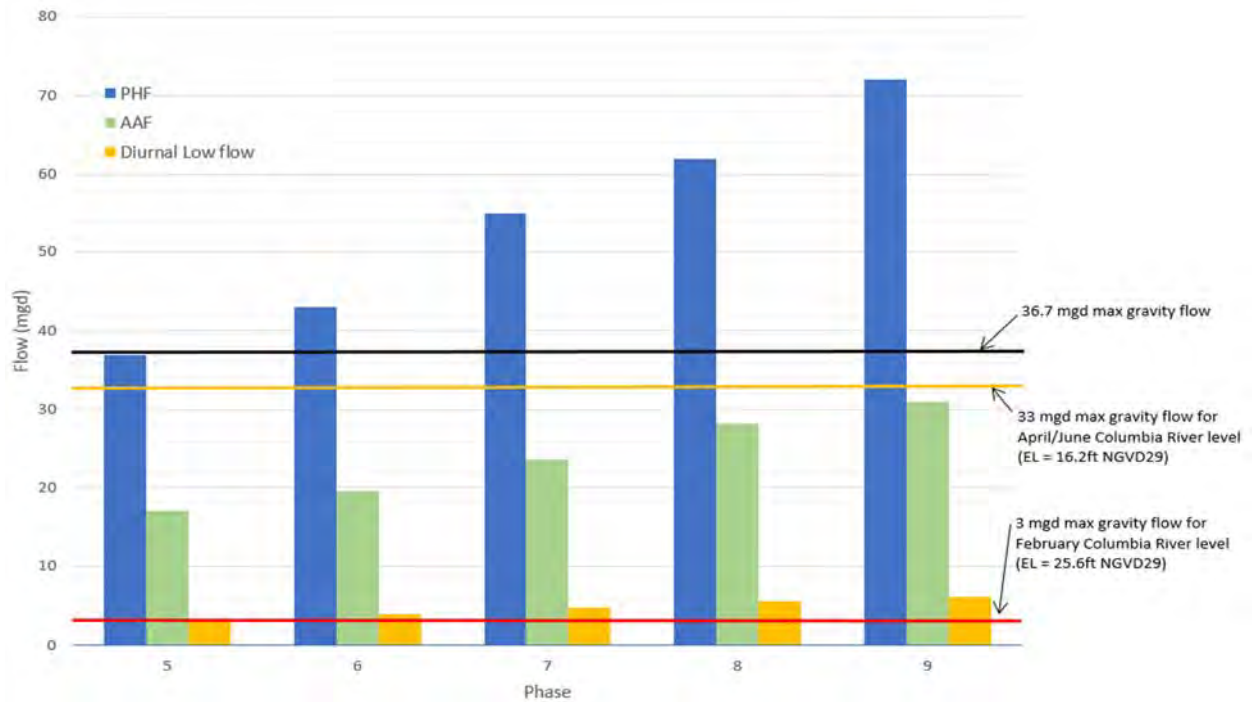


Figure 4-3. Effluent Flow by Phase with Gravity flows at a Variety of River Elevations
Assumes effluent wet well hydraulic elevation = 25.68 feet
Engineering Report for the Phase 5A Project—Columbia River Outfall and Effluent Pipeline

Effluent flows used for the outfall design were defined in Section 3.1.

Figure 4-4 shows curves for a 48-inch-diameter effluent pipeline system with one or more effluent pumps operating during 100-year flood river elevation (25.6 feet) conditions. These system curves assume the most conservative scenario, which is to use high-density polyethylene (HDPE) piping for the two sections of the effluent pipeline where pipe material options are allowed. The figure also shows the existing 30-inch-diameter effluent pipeline with one pump operating. The system curves depict the static head associated with the PUMP OFF elevation (24.18 feet).

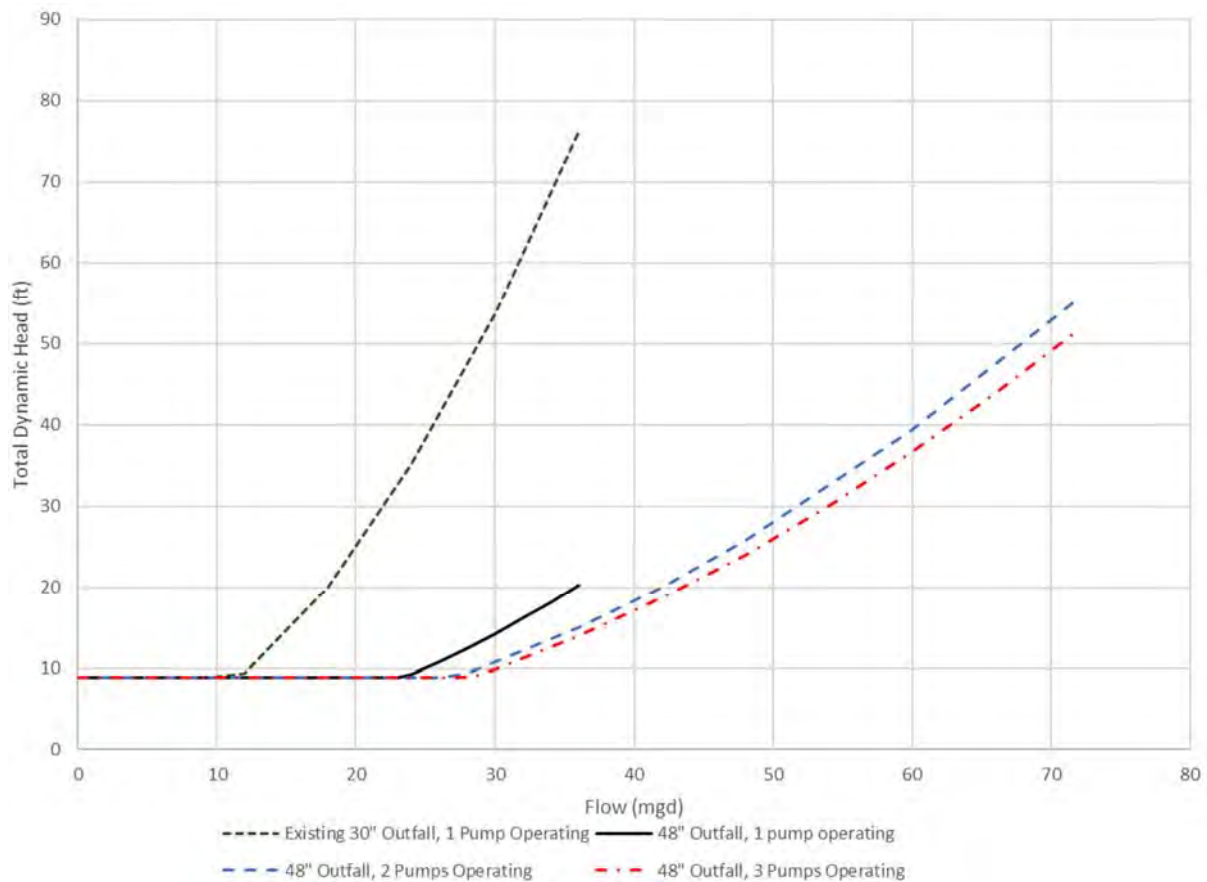


Figure 4-4. System Curves, New 48-Inch-Diameter and Existing 30-Inch-Diameter Pipelines

Assumes HDPE pipe sections

Engineering Report for the Phase 5A Project—Columbia River Outfall and Effluent Pipeline

Pump station considerations include the following:

- **Number of Pumps.** The number of effluent pumps will match current conditions, which currently includes four pumps.
- **Total Dynamic Head.** The minimum total dynamic head for the system curves shown in Figure 4-4 is 10.3 feet. This corresponds to a difference in the elevations of the centerline of the pump discharge piping (34.5 feet) and the PUMP OFF elevation (24.2 feet). At this point, the effluent pumps lift the water up out of the wet well to discharge piping elevation where an air/vacuum valve will vent the pipe to atmosphere to avoid a vacuum siphon condition with effluent flowing by gravity into and through the effluent pipeline when the pumps shut off.
- **Hydraulic Design Criteria.** The SCTP is designed to hydraulically convey and treat all designed flows at the 100-year flood stage. The 100-year flood stage (base flood) at Columbia River RM 96 is 25.5 feet NGVD29. PHF for Phase 5 improvements is 34 mgd.
- **Reliability and Redundancy.** The U.S. Environmental Protection Agency (EPA) requires that wastewater facilities meet the requirements for reliability and redundancy in their treatment components and associated equipment. The reliability standards establish minimum levels of reliability for three classes of wastewater works. To ensure redundancy and reliability, the SCTP has proper hydraulics to operate and treat the PHF with the largest effluent pump out of service during events up to the 100-year flood stage.

4.1.5 Pipeline Design Criteria

The pipeline design criteria are as follows:

- **Pipe Materials and Design Life.** The pipeline materials will be selected for a service life of 50 years. HDPE pipe and welded steel pipe with high quality lining and coating (and cathodic protection if necessary in corrosive soils) have a long history of service. The allowable pipe materials in various locations along the route are summarized in Table 4-1. Near the Columbia River and at the in-water portions of the alignment, steel pipe is preferred due to its weight, strength, and long history of use for outfalls. At other locations, either HDPE or steel pipe would be suitable; the intent is to allow contractors to bid on either material. Having alternate materials will provide for a more competitive bidding environment.
- **Pipe Support Requirements.** Based on the geotechnical exploration, the native soils are adequate to support the effluent pipeline. Imported material will be needed for backfilling the trench in the pipe zone. This imported material can be adequately compacted and will resist excessive pipe deflection (formation of an ellipse) due to the weight of soil above the pipe. Above the pipe zone, it may be possible to use native material that was excavated from the trench, depending on the moisture content and the required degree of compaction.

The in-water outfall diffuser section will be pile-supported so that it will resist lateral and vertical forces and it will not move. For the outfall portion of the pipe (Station 9+70 to 19+50), three ball joints are recommended. These joints provide for significant angular deflection both during installation and operation. In the extreme case of significant bank erosion and loss of support under the pipe, these joints would allow the pipe to flex and accommodate some degree of movement without breakage.

- **Pipe Protection Along the Shoreline.** A concrete revetment mat placement over the outfall pipe and bedding materials is recommended where the pipe profile drops from elevation 10 feet to elevation minus 7 feet near Station 19+00. If future erosion of the bank reaches the mat, the exposed mat will serve as an indicator that the pipe could be exposed if the erosion continues. In addition, if the mat is exposed, it will minimize future erosion of the bank and provide additional time for subsequent action.
- **Pipe Inspection Design Elements.** Several 24-inch-diameter access ports (manholes) will be provided along the alignment of the 48-inch-diameter effluent pipeline. These ports can be used for access during construction to remove the internal pipe stulls and to inspect the pipe joints and lining. After the pipeline is constructed, the ports can be used for access by maintenance staff to inspect the pipe interior either by personnel entry or closed-circuit television (CCTV) equipment, make repairs to the lining if necessary, and to lower a pump into the pipe for dewatering.

Most large diameter inspection companies will have at least 1,500 lineal feet of cable to deploy a crawling CCTV camera. Based on this length, access points for inserting a CCTV camera can be as far apart as 3,000 feet. For the effluent pipeline, the maximum length between access points is 1,300 feet. The air valves provided at high points and other critical locations along the route are designed to be installed on the top of a blind flange. This blind flange can be removed for access into the pipe. By combining the air valve and access functions, the spacing of access points can easily be reduced from the maximum allowable.

Two access locations are provided in the section of pipe with the diffusers. A blind flange will be provided on the downstream end of the 48-inch-diameter diffuser pipe, and the most downstream diffuser will include an access port. These entry points can be accessed by a diver if necessary to perform inspections or repairs.

Table 4-1. Allowable Pipe Materials by Location Along the Pipeline Route
Engineering Report for the Phase 5A Project—Columbia River Outfall and Effluent Pipeline

Location	Lined and Coated Welded Steel Pipe	HDPE Pipe
Connections and fittings at the tie-in to the existing piping at the pump station	x	
Between the pump station connection and the railroad undercrossing	x	
Railroad undercrossing	x	
Salmon Creek crossing	x	
West side of Salmon Creek to Lake River crossing	x	x
Lake River crossing	x	
West side of Lake River to Lower River Road	x	x
Lower River Road to end of outfall pipe	x	

4.1.6 Appurtenances: Valves and Inspection Points

Drain valves (commonly referred to as blowoffs) to allow complete draining of the pipe for future inspection were discussed with operations and management staff, but have not been provided in the 30 percent design. SCTP Operations staff members have successfully dewatered pipelines using submersible pumps lowered into the pipe from access ports, and has indicated that with strategically placed access ports, the same procedure could be used to dewater the effluent pipeline.

Combination air/vacuum release valves will be provided at the high points in the profile and at other points where air may accumulate during operation. A typical example of an air accumulation location is where the pipe profile is on a slight downslope that increases to a steeper downslope. The flowing effluent tends to pull air with the current, provided the downward slope is gentle. Where the downward slope increases, the air no longer moves with the flow, and pockets of air tend to accumulate at the grade break if no outlet is provided. Examples of this occur at Stations 19+30 and 72+90. At Station 72+90, the physical location of the grade break is such that access with equipment is difficult during periods of high water in Salmon Creek. To avoid installation of an air valve at this location, a small diameter air vent pipe is proposed to convey the air to a location where access to an air valve is more convenient. The air vent pipe will be installed inside the steel casing under the railroad. The air vent pipe will terminate at an air valve enclosed in a vault near Station 78+50.

Enclosures commonly used for air valves include circular precast concrete manholes and rectangular precast vaults. SCTP Operations staff members have indicated a preference for rectangular precast vaults with access ladders and dual hatches. When the hatches are opened, natural light enters the vault, personnel can easily stand upright in the vault, and adequate working space is available for maintenance crews. The hatches can be provided with locks to restrict unauthorized access.

4.1.7 Navigation Marker

The existing effluent outfall in the Columbia River is identified as a vessel navigation hazard by a three-pile wood dolphin that was installed with the outfall in 1974. The USCG regulates the dolphin as a private aid to navigation (PATON).

The three-pile dolphin appears to be in good condition and could continue to serve its navigational purpose that includes defining the proximity of the SCTP outfall diffuser as well as the end of the Willow Pile Dike. However, it is assumed that the existing outfall diffuser risers will be removed, and the new

diffuser will terminate approximately 200 feet upriver and farther into the river. After consultation with the USCG, the Alliance will determine whether to leave the existing PATON in place or remove it.

A PATON will be necessary to mark the new offshore SCTP outfall diffuser terminus, requiring USCG approval of the design and installation; and it will need solar-powered lighting and signage to warn commercial vessels and public boaters of the presence of an exposed pipe structure. In addition, the USCG will be notified of the outfall and diffuser route so that they can include it on the National Ocean Survey chart for the Columbia River.

The new navigation marker will need to be made of steel piles for greatest strength and useful life. The steel piles could be driven with a vibratory hammer rather than an impact hammer, which would reduce hydroacoustic impacts to fish and marine mammals. If the existing pile dolphin required removal, then the existing piles would need to be extracted, or cut off at 3 feet below riverbed, or cut and driven below the riverbed surface. The riverbed at the site consists of sand.

4.1.8 Existing Effluent Pipeline and Diffuser

The existing SCTP outfall pipeline was installed in 1974; it consists of a 30-inch-diameter prestressed concrete cylinder pipe that extends 7,462 feet from the SCTP to the diffuser at RM 96 in the Columbia River. The existing outfall pipe is buried along its length and extends approximately 300 feet from the east bank of the river and terminates with a 40-foot-long diffuser section at a depth of 15 to 20 feet below CRD at low river stage. The existing outfall diffuser has five 10-inch risers at a 10-foot spacing, and each riser has three 5-inch ports in a turret configuration. The outfall pipeline is pile-supported along the last 345-foot length into the Columbia River. In 2004, a 200-foot length of the pipeline was protected with quarry rock and riprap cover to mitigate shoreline erosion that exposed 80 feet of pipe at the water's edge. This existing outfall pipeline and diffuser is 42 years old and has hydraulic capacity limitations.

Maintaining or removing the portion of the existing 30-inch-diameter effluent pipeline and outfall that is in the Columbia River will be evaluated in the alternatives analysis. Several criteria are considered regarding this question, as follows:

- Necessity (or lack thereof) for redundancy for O&M flexibility after the new outfall is constructed
- Age and condition of the existing effluent pipeline
- Consideration of potential future uses (i.e., reuse)
- Present versus future cost of outfall diffuser and effluent pipe removal
- Risk and liability for the Alliance of a second buried pipeline, especially in the Columbia River where shoreline erosion is a concern
- Existing and future DNR easement requirements
- If only the outfall is removed, benefit and need (or lack of need) for the intertie between the new and existing effluent pipelines

4.1.9 Risk

A risk register with over 100 risk elements was prepared for the project. It includes several general categories of risk (see list below), the impact of the risk, the probability of the risk, an overall risk ranking, a recommended type of risk mitigation, the proposed treatment plan, and a risk owner. General categories of registered risk include the following:

- **Public Involvement.** Risk mitigation will include developing a public involvement and outreach plan, addressing satisfaction of stakeholders through SEPA, and maintaining open communications with tribes and property owners along alignment.

- **Archaeological and Historic Resources.** Risk mitigation includes following the existing pipe alignment to minimize impact, minimizing construction footprint, and avoiding or protecting archaeological and historic resources if they are identified in the construction footprint.
- **Permitting.** Risk mitigation includes early regulatory agency engagement and communication with Ecology, DNR, USACE, Washington State Department of Fish and Wildlife (WDFW), NMFS, and USCG; proactive field investigations to keep permitting on schedule; a sound engineering approach that minimizes environmental impacts; and managing construction timing and best management practices.
- **Wetlands.** Risk mitigation includes demonstrating that the selected design is the "least environmentally damaging practicable alternative," avoiding permanent wetland impacts, preparing a resource restoration strategy, considering advance mitigation to reduce the monitoring period and postconstruction monitoring cost, and early negotiation with property owners for onsite mitigation.
- **Construction Related to Trenchless Undercrossing of Railroad.** Risk mitigation includes early coordination with BNSF to determine encroachment specifications, conducting thorough geotechnical investigations, careful evaluation of trenchless technology alternatives and feasibility for railroad undercrossing as they relate to site-specific soil and groundwater conditions, site access, and environmental considerations. Also, planning the pipeline undercrossing at sufficient depth and bridge abutment setback to avoid impacts to railroad, and requiring trenchless methods that have good face control to limit potential for overmining that results in settlement. These considerations are further described in Appendix H (Trenchless Crossing Technical Memorandum).
- **BNSF Railroad Crossings by Vehicles.** To address uncertainty about allowable access across the railroad, risk mitigation includes limiting types and volumes of equipment allowed to cross the railroad, understanding of permit conditions for railroad crossings, and verifying that the existing crossings (railroad bridge at Salmon Creek, railroad bridge at Curtis Lake Ranch, and at-grade crossing at Curtis Lake Ranch) are adequate for construction access to the Curtis Lake Ranch property. An alternate access plan will be developed in the event the railroad crossing is unacceptably constrained.
- **Engineering Design of Effluent Pipeline Alignment.** Risk mitigation includes conducting wetland, biological, archaeological, and hazmat studies in the Area of Project Effect to minimize alignment constraints, allow for flexibility during construction, and base alignment selection on the balance of risk and cost; preparing technical analyses to estimate erosion and scour rates at river crossings to mitigate potential future exposure of pipe (i.e., cover materials and depth of burial) and potholing of existing petroleum and communication utilities to ensure avoidance; and developing an evaluation of preferred pipe materials.
- **Engineering Design at Existing Effluent Pump Station.** Risk mitigation includes developing a phasing plan from current low/high flows to buildout and confirming stable controls and overlaps, understanding operational impacts of range of flows and river stages to design appropriate pumping equipment, understanding intermittent operations, and considering ability to retrofit selected pumps to cost-effectively provide phasing.
- **Seismicity.** Seismic risk mitigation includes considering seismic performance in selection of pipe material and fittings, selecting advantageous pipeline routing, and considering installation of pipe at greater depths below potential slope failure zones. Mitigation by ground improvement appears too expensive for the project. Mitigation measures for the outfall pipeline and diffuser section in the Columbia River include the use of ball-joints to allow settlement and pile-support for the diffuser section.

- **Pipeline Construction at River Undercrossings Using Open Cut.** Risk mitigation includes setting a schedule that allows for construction during summer and fall (low water) months, completing geotechnical evaluation, installing piezometers for groundwater monitoring, developing technical scour analysis based on tidal and discharge flow velocities at Lake River and Salmon Creek crossings to support design and permitting approach, requiring contractor to establish spill pollution and control plan, establishing performance specifications for contractor, and discussing construction approach with permitting agencies.
- **Construction Related to Columbia River Outfall.** Risk mitigation includes discussing best approach alternatives with marine contractors, establishing wide excavation limits to allow open excavation using flat slopes, to the extent possible establishing shallow pipeline burial depth, developing engineering analyses of shoreline erosion impacts and planning for post-construction riverbank restoration/stabilization. Riverbank restoration/stabilization planning is also needed for demolition of the existing outfall diffuser. If the existing river outfall is abandoned, it will be necessary to discuss the removal of diffuser risers and abandonment of onshore pipe structures and riprap pipe cover with DNR. The last 345 feet of outfall pipe is pile-supported and removal of this buried wood structure would be costly, with no benefit to the river.
- **Landowner and Easement Risks.** Risk mitigation includes working closely with private and public (DNR, WSDOT) landowners to foster good relationships and obtain buy-in on required temporary construction and permanent easements.
- **Post-Construction Testing and Restoration.** Risk mitigation includes preparing detailed specifications for testing of effluent pipeline and pump station and for restoration of farmland, roads, and rivers impacted by project staging, access, and construction activities.
- **Elevated Project Cost Estimate.** Risk mitigation includes performing cost-informed comparisons and decisions in the alternatives evaluation phase.
- **Communications of Project Issues to Internal and External Stakeholders.** Risk mitigation includes continuing to work closely with internal stakeholders (Alliance Board members) to keep them informed and supportive of project changes as well as continuing to work closely with appropriate external stakeholders, tribes, and regulatory agencies to gain support and ensure a successful project.

A detailed assessment and evaluation of the 100 project risks indicates that most of the risks, after risk mitigation treatment, are low or medium risks. Most of the risks can be avoided or mitigated through field investigations to better understand site conditions, by preparing design documents that eliminate risk elements, and with early regulatory and stakeholder engagement. A few risk elements, such as limited construction access, presence of archaeological resources, potential regulatory requirements, and seismic risks, can be minimized but difficult to avoid and will need to be accepted.

The highest project risk elements, and associated mitigation approaches, are as follows:

- **Trenchless Crossing of the BNSF Railroad.** Risks associated with the trenchless crossing of the railroad include encountering difficult geologic conditions (boulders, woody debris, extremely soft soils), difficulty controlling line and grade, equipment breakdown, limited access for retrieval of trenchless equipment (depending on the trenchless method used), and high groundwater conditions. To mitigate these risks, the following actions are proposed: use of auger boring techniques rather than microtunneling, keeping the pipe profile as high as possible to reduce groundwater concerns. Additional information regarding the trenchless crossing alternatives of the BNSF railroad and associated risks and mitigation approach is provided in the Trenchless Crossing Technical Memorandum (Appendix H).

- **Crossing of Salmon Creek and Lake River.** Risks associated with tunneling at the stream crossings include the likelihood of encountering difficult geologic conditions (as described in the paragraph above), difficulty constructing and dewatering shafts in the high groundwater areas adjacent to the streams, and, in the case of the east side of Salmon Creek, difficult access. The use of a horizontal directional drilling (HDD) trenchless installation method also would include the risk of a release of drilling fluid into the stream or river (referred to as a *frac-out*). Risks associated with open trenching of the streams include difficulty with obtaining permits, difficulty controlling water, possible discharges of silt into the streams, difficulty with completing the pipe joints, difficulty with placement and compaction of trench backfill, streambank restoration, and potential for impacting boaters or other users of the waterways. While neither HDD nor open cut method is risk-free, the open cut method of installing the pipeline appears to have less risk. The open cut method would include a system to limit the width of the excavated trench and the disturbance to the waterbody.
- **Future Scour at Stream Crossings.** Bathymetric surveys of Salmon Creek and Lake River indicate areas of scouring. There is a risk of additional scour and it is possible that the effluent pipeline could become exposed or undermined. Risk mitigation includes selection of an alignment that avoids the existing scour areas, locating the effluent pipeline in areas that appear least likely to have additional scouring, and specifying protective length and depth of burial.
- **Dynamics of Columbia River and Associated Bank Erosion and Riverbed Elevation.** An evaluation of the Columbia River shoreline stability has shown that there is significant risk of further erosion along the riverbank (Appendix D). Risk mitigation will include consideration of deeper burial of pipe between the Columbia River and NW Lower River Road, and use of a buried concrete revetment mat for protection of the pipe in the event that the shoreline continues to erode. Seismic risks leading to liquefaction of soils also present the need to consider adequate pipe support through use of pile supports and ball joints. Ball joints will allow up to 15 degrees of rotation if the dynamic banks exhibit movement and the pipeline bedding is impacted. Riverbed elevations (sand wave crests and troughs) at the outfall diffuser ports pose risk of burial and erosion to increase the length of exposed diffuser risers. Risk mitigation for riverbed elevation changes includes coastal engineering analysis and prediction of bedform heights at the diffuser site, port elevations above predicted sand waves, and structural strength of risers and ports exposed to river currents and large woody debris.
- **Treatment Plant Shutdown Requirements.** The SCTP has limited shutdown capability/duration during construction at the effluent pump station and at the tie-in near the Columbia River. A construction delay could result in an operational failure at the plant and lead to an overflow. Mitigation of risk includes evaluating construction sequencing and use of bypass pumping to ensure that the SCTP can continue to discharge treated effluent without interruption.

4.1.10 Anticipated NPDES Permit Conditions

Federal and state regulations require that effluent limitations set forth in an NPDES permit must include technology-based limitations for municipal discharges and these limits are set by regulation (40 Code of Federal Regulations (CFR) 133, and WAC 173-220 and 173-221). Water quality-based effluent limitations are based upon compliance with Washington's Surface Water Quality Standards (WAC 173-201A) and Sediment Quality Standards (WAC 173-204), or the National Toxics Rule (40 CFR 131.36). The current SCTP NPDES permit includes technology-based effluent limits as follows:

- Biochemical oxygen demand (BOD) (5-day): monthly average of 30 mg/L; 3,741 pounds per day (lb/day); and 85 percent removal of influent BOD; and weekly average of 45 mg/L; 5,612 lb/day
- Total suspended solids (TSS): monthly average of 30 mg/L; 3,741 lb/day; and 85 percent removal of influent TSS; and weekly average of 45 mg/L; 5,612 lb/day

- Fecal coliform bacteria: monthly average of 200 organisms/100 milliliters (mL); and weekly average of 400 organisms/100 mL
- pH: daily minimum equal to or greater than 6.0 and the daily maximum less than or equal to 9.0

The current NPDES permit also includes water-quality-based effluent limits for total ammonia (as NH₃-N) discharged as: monthly average of 18.7 mg/L and daily maximum of 37.5 mg/L. The permit also includes an acute Whole Effluent Toxicity (WET) limit of “no acute toxicity detected in a test concentration representing the acute critical effluent concentration (ACEC).”

Anticipated future NPDES permit limits and conditions should include the same technology-based effluent limits for BOD, TSS, and fecal coliform bacteria. Acute WET limits would also be expected to remain the same. As a result of Columbia River monitoring data upstream of Vancouver and upstream 303(d) listings of pH, effluent limits for pH may be expected to be revised to daily minimum of 6.0 and daily maximum of 8.5.

With the improvements made as proposed in this Phase 5A Project, the SCTP will no longer show a reasonable potential to exceed ammonia water quality criteria in the Columbia River, and, therefore, the ammonia effluent limits could be removed since the SCTP effluent ammonia concentrations were reduced substantially in 2011 and the new SCTP outfall diffuser will provide dilutions at the acute and chronic mixing zone boundaries that are three times greater than needed to comply with water quality criteria. Section 402(o)(1) of the Clean Water Act (CWA) may allow removal (or relaxation) of effluent limits when there have been substantial alterations or additions to the permitted facilities, and both treatment improvements and a new diffuser could qualify for this condition. However, the Columbia River reach where the SCTP discharges is currently listed in Ecology’s 2015 303(d) list of impaired waters for dissolved oxygen. Unless this dissolved oxygen listing of impairment is removed in future water quality assessments by Ecology, the SCTP effluent ammonia limits would be expected to remain in the NPDES permit (per CWA Sections 402(o)(1) and 303(d)(4)).

It is relevant to recognize that the four months of extensive 2015 water quality measurements in the Columbia River near RM 96 yielded no exceedances of Washington’s surface water quality standards for pH, dissolved oxygen, and turbidity. These water quality monitoring data have been submitted to Ecology for their use in the next water quality assessment and evaluation of 303(d) listings.

The Columbia River has been on Ecology’s 303(d) list for temperature impairments for decades. In 2003, EPA Region 10 released temperature guidance for Pacific Northwest states and EPA published *Columbia/Snake Rivers Temperature TMDL, Preliminary Draft* (EPA, 2003). The EPA’s preliminary draft temperature TMDL for the Columbia River included a draft total heat load allocation of 926.3 megawatts for the group of dischargers between RM 112 and RM 95 (including SCTP, two Vancouver WWTPs, City of Portland Columbia Boulevard WWTP, and other smaller discharge sources). The preliminary draft TMDL also included a point source maximum temperature increase of 0.026°C in the river, which is equivalent to the current state water quality standard of 0.3°C maximum allowable increase at a mixing zone boundary. The draft TMDL has not advanced, but, in 2016, two groups filed notice of intent to sue EPA for this inaction. Eventually the SCTP should be expected to receive an effluent heat load allocation, once the EPA’s temperature TMDL is completed and litigation is complete.

Future NPDES permits may include water quality-based effluent limits for effluent chemicals that show a calculated reasonable potential to exceed human health chemical criteria. The SCTP would be expected to conduct more frequent effluent monitoring for chemicals that show a preliminary reasonable potential to exceed human health chemical criteria in order to generate sufficient data to allow Ecology to assess the reasonable potential. Some chemicals could require source control measures and public education on disposal methods.

Ecology will also be assessing implementation options for arsenic because the background Columbia River water concentrations exceed the current human health criteria.

4.1.11 Alternatives Scoring

Before concluding that the SCTP required a new effluent pipeline and outfall to the Columbia River, an alternatives evaluation was conducted to consider wastewater disposal options including reuse, water conservation, diversion to Vancouver, SCTP advanced treatment, and Lake River discharge. Once the conclusion was made, a second tier of alternatives analysis was required to evaluate possible effluent pipeline routes to the Columbia River and Columbia River discharge sites.

The intent of alternatives development was to identify effluent pipeline alignments, outfall configurations, and construction alternatives that are practicable and permittable. These alternatives are described below in Sections 4.3, 4.4, and 4.5. Only alternatives that are both practicable and reasonable were considered. Of those, the least environmentally-damaging practicable alternative must be selected to satisfy environmental regulations. The analysis utilized non-cost evaluation criteria that support selection of the least environmentally damaging alternative to streamline the alternative evaluation process and support permissibility of the preferred alternative. The term "practicable" means available and capable of being implemented after taking into consideration cost, existing technology, and logistics in light of overall project purposes.

Under the National Environmental Policy Act (NEPA) and the CWA Section 404 (b)(1) Guidelines, the USACE is required to evaluate alternatives to a proposed project. The project team developed specific information and rationale as to why the proposed project is the least environmentally damaging practicable alternative using the USACE-recommended matrix that addresses alternative onsite configurations in terms of location, timing, work method, costs, logistics, and existing technology. These categories were broken down further into the specific design criteria used in site development to help focus the analysis. The CWA Section 404(b)(1) Guidelines use the applicable criteria shown in Table 4-2, grouped by evaluation criteria. These criteria were used to compare and rank the effluent pipeline and outfall alternatives.

Table 4-2. List of Non-Cost Evaluation Criteria and Goals

Engineering Report for the Phase 5A Project—Columbia River Outfall and Effluent Pipeline

Evaluation Criteria	Goals
Location	<ul style="list-style-type: none"> • Avoids disruption of surface hydrology • Favors previously used sites • Minimizes the extent of discharge plume • Avoids sites with unique habitat or other value • Minimizes impacts associated with future maintenance activities
Timing	<ul style="list-style-type: none"> • Construction during low flow • Construction during low fish presence • Construction during low groundwater conditions
Technology	<ul style="list-style-type: none"> • Uses appropriate equipment (e.g., low ground pressure) • Minimizes footprint • Creates ecological uplift • Reduces risk of failure due to catastrophic events • Proactively plans for compliance with increasingly stringent regulations • Provides flexibility to respond to future land use and economic development
Work Method	<ul style="list-style-type: none"> • Maintains natural substrate contours (e.g., avoids net floodplain fills) • Clearing outside migratory bird nesting season

Table 4-2. List of Non-Cost Evaluation Criteria and Goals*Engineering Report for the Phase 5A Project—Columbia River Outfall and Effluent Pipeline*

Evaluation Criteria	Goals
Logistics	<ul style="list-style-type: none"> • Minimizes impact to treatment facilities during construction • Minimizes impact to property owners • Minimizes temporary disturbance during construction
Cost	<ul style="list-style-type: none"> • Achieves reasonable life-cycle cost

It was important to ensure the evaluation criteria utilized for the project demonstrate connectivity to Alliance values, which are intended to shape investments and drive decisions related to Alliance infrastructure. The Alliance values are as follows:

- 1. Ensure reliable, predictable service for all customers**
2. Manage resources responsibly, efficiently, and equitably
- 3. Protect public and environmental health**
4. Optimize use of existing facilities
5. Be financially transparent
- 6. Use new technologies to achieve system efficiencies and environmental protection**
7. Provide a fair, positive, and secure work environment for utility employees
- 8. Ensure capacity to support regional land use and economic development decisions**
- 9. Invest in improvements that create system-wide benefits**
10. Make business decisions collaboratively with all partners

While several of these do not have specific applicability to the project alternative evaluation, the **bolded** values are directly related to the criteria from the CWA Section 404(b)(1) Guidelines.

4.2 No Action Alternatives for Effluent Pipeline, Outfall, and Effluent Pump Station

The no action alternatives include no build, limiting acceptance of Battle Ground flows, Vancouver Diversion, and water reclamation and reuse as described separately below.

4.2.1 No Build

Under no action, the Alliance would not implement the Phase 5A Project—Columbia River Outfall and Effluent Pipeline, and would not upgrade the existing effluent disposal system. The Alliance would not satisfy the targets and commitments for incremental future treatment capacity increases, as set forth in the 2013 Facilities Plan (CH2M, 2013), which the Alliance needs to support planned growth in the service district.

By not constructing a new 48-inch-diameter effluent pipeline, the Alliance would be unable to comply with Ecology’s requirement that SCTP capacity improvements for each planned expansion begin once influent flows reach 85 percent of the rated capacity identified in the NPDES waste discharge permit’s facility loading design criteria for flow, BOD load, or TSS load. Moreover, the SCTP would be unable to accommodate the projected ultimate PHF of 72.3 mgd. Furthermore, the existing pipeline would not be available as a contingency transmission line to facilitate continuous treatment plant operation during routine effluent pipeline maintenance.

By not implementing the project, the Alliance would be unable to accept wastewater from the City of Ridgefield and to decommission that city's aging wastewater treatment plant and outfall into Lake River (after additional SCTP projects are in place).

By not constructing a new effluent outfall, the Alliance would not address the ongoing hazard of Columbia River shoreline erosion and potential pipeline exposure, nor would they address the ongoing maintenance concern for sand waves burying the existing diffuser's risers and ports.

By not constructing an improved outfall diffuser, the Alliance would be unable to ensure adequate mixing and dilution of treated water discharged into the Columbia River, and would be less able to address future discharge limits of their NPDES waste discharge permit.

The Phase 5A Project's effluent pump station improvements would not be needed if the new 48-inch-diameter effluent pipeline were not constructed.

4.2.2 Limiting Acceptance of Battle Ground Flows

If the SCTP treatment capacity could not be increased because a larger diameter effluent pipeline would not be constructed, the Alliance might reduce future SCTP wastewater treatment demand outlined in the 2013 Facilities Plan (CH2M, 2013) by limiting the City of Battle Ground's ability to purchase additional treatment, outfall, and pump station capacity at the SCTP (BergerABAM, 2017b). By limiting acceptance of Battle Ground's flows, the city's treatment demand would be displaced by: (1) purchasing additional capacity and constructing a new force main and interceptor system to convey wastewater to the City of Vancouver Westside Water Reclamation Facility (WWRF), or (2) developing a local water reclamation facility (e.g., membrane bioreactor, pump station, 16-inch-diameter force main, and 15 acres of infiltration basins) that would produce a Class A effluent and would meet reclaimed water requirements of RCW 90.46. The city decided to continue purchasing additional capacity at SCTP as the least cost treatment solution with the least regulatory risk. Furthermore, diverting flows from Battle Ground alone would not alleviate the SCTP's need for additional future capacity.

4.2.3 Vancouver Diversion

If treatment capacity at the SCTP could not be increased due to limited effluent transmission capacity, the Alliance might be forced to pursue flow diversion to the City of Vancouver WWRF, which has identified available capacity. Flow diversion would reduce the flow discharged from the SCTP. Diverting a portion of flow from the Alliance service area to the WWRF could take advantage of available capacity in Vancouver's system and postpone or complement capacity increases within the SCTP.

The most effective diversion point is at the 117th Street Pump Station. This high-head, dual-use pump station at Salmon Creek Park near Kline Pond discharges to the SCTP via a force main. The pump station is configured to ultimately pump flow to both the SCTP and the City of Vancouver WWRF. The Vancouver Diversion would include construction of a 30-inch-diameter pipeline approximately 5 miles long connecting the 117th Street Pump Station Force Main with the WWRF.

The Vancouver Diversion would provide flexibility by allowing staff to operate the wastewater system in a manner that would route a portion of flows to either the SCTP or Vancouver's system. This flexibility could take advantage of seasonal permit variations, or better accommodate peak flow events. The pump station could divert only wet weather peak flow, or flow could be diverted year-round, depending on future permitting and operational constraints.

The disadvantage of the Vancouver Diversion is the significant initial cost to implement it, compared to providing that same capacity within the SCTP, which allows incremental investment as capacity is needed. The cost of the force main, associated City of Vancouver WWRF improvements, required SCTP outfall pipe replacement, and WWRF capacity purchase would be nearly \$89 million in 2014 dollars (or \$100 million in 2018 dollars with an estimated 3 percent escalation per year).

Flow diversion is viable for the next several increments of capacity needed for the Alliance service area, but will not allow for complete replacement of the SCTP and its associated outfall. The Vancouver Diversion would provide approximately 6 mgd of excess available capacity toward the SCTP long-term need for approximately another 20 mgd of capacity. For reasons of prohibitive cost and factors, flow diversion would not meet the Alliance’s need for increased long-term capacity.

4.2.4 Water Reclamation and Reuse

The SCTP currently reliably produces Class D reclaimed water and very consistently produces Class C reclaimed water. The use of this quality of reclaimed water for most food crops, groundwater recharge, as well as irrigation of landscape areas in public areas would not be allowed. However, SCTP’s Class C or D effluent could be utilized for other acceptable purposes, and the plant may be producing Classes A+, A, and B effluent in the future.

4.2.4.1 Potential Reclaimed Water Users

Several potential opportunities exist for reclaiming and reusing water from the SCTP. Water could be reclaimed from the effluent at the SCTP. This could involve routing reclaimed water distribution piping from the SCTP to the points of reuse if significant users are identified. Parks, open spaces, agricultural areas, golf courses, and schools are potential candidates for using reclaimed water. The two most likely potential users of reclaimed water are the agricultural area west of the SCTP and local parks and schoolyards east and north of SCTP.

Class D Reclaimed Water Use for Agricultural Area West of the SCTP

There are several large plots of land within 2 miles of the existing outfall from the SCTP where food crops are now grown for livestock feed, and where lands are maintained by the state for wildlife. Seasonally, these crops need to be irrigated. Currently, this is done using well water or water from the Columbia River, both readily available and inexpensive sources of water. In July, August, and September, Class D reclaimed water from the SCTP could be conveyed through the existing outfall to a central distribution facility, and the effluent used in lieu of the current water sources. The demand for Class D effluent is estimated to be on the order of 27,000 gallons per acre per week. An estimated 1,700 acres are available for irrigation; therefore, 46 million gallons per week (or 6.6 mgd) of Class D reclaimed water could potentially be used for seasonal irrigation purposes. The estimated capital cost of the 6.6 mgd pump station and distribution system for the Class D reclaimed water for 1,700 acres is \$13,500,000. The cost of producing this water at the SCTP and distributing the Class D reuse water to the 1,700 available acres is estimated to be about \$0.0028 per gallon. Reuse of Class D reclaimed water is not cost-effective at this time because the cost is high compared to the readily available groundwater and Columbia River sources.

Class A Reclaimed Water Use on Local Parks and Schoolyards East and North of SCTP

There are several schools, small parks, and a golf course within 3.5 miles of the SCTP where Class A reclaimed water from the SCTP could be used for seasonal irrigation. Currently, this is done using well water or potable water from Clark Public Utilities (CPU), a readily available and inexpensive source of water (cost for CPU water is approximately \$0.0015 per gallon). In July, August, and September, Class A reclaimed water from the SCTP could be conveyed through a new reclaimed water distribution system to the points of use. Reclamation would require the construction of coagulation and filtration facilities at the SCTP to meet the Class A requirement. The demand for Class A effluent is estimated to be on the order of 27,000 gallons per acre per week. An estimated 85 acres are available for irrigation; therefore, 3 million gallons of Class A reclaimed water per week (0.43 mgd) could potentially be used for seasonal irrigation purposes. The capital cost of 0.43 mgd capacity distribution facilities to the reuse sites is estimated to be \$2,700,000. The cost of producing this water at the SCTP and distributing the Class A reuse water to the 85 available acres is estimated to be about \$0.0065 per gallon. This cost is higher

than the cost of water from CPU; therefore, it is not cost-effective at this time to implement a Class A reclaimed water program.

4.3 Effluent Pipeline Alternatives

The Alliance developed and evaluated alternatives for a new effluent pipeline and outfall. Components were defined based on construction methods and screened based on cost and viability. The remaining components were developed into complete alternatives that were evaluated and ranked based on the evaluation criteria and an alternative analysis approach developed by the Alliance to identify a preferred alternative. Alternative development involved brainstorming potential components based on construction methods at various crossings/locations, and screening based on cost and viability factors.

The engineering analysis considered alternative designs and alignments for conveyance piping from the discharge pump station at the SCTP to the junction with the new outfall in the Columbia River. The proposed effluent pipe will begin at the discharge pump station at the western end of the SCTP and extend approximately 6,100 feet (continuing in the westerly direction) to the edge of NW Lower River Road, which parallels the Columbia River. A structure at this location will transition the new effluent line(s) to the planned outfall pipe extending into the Columbia River. The installation of the new line(s) will include construction in open fields that are pasture or farmed for hay production and crossing under BNSF railroad, Salmon Creek, Lake River, and NW Lower River Road. Curtis Lake and Round Lake may be peripherally impacted. (Both are shallow bodies of water where the water levels fluctuate significantly, filling during winter rains, receding during the summer.)

The following discussion presents material and pipe diameter considerations as well as alternative construction methods and alignments considered for each reach of the pipeline alignment.

4.3.1 Three Pipeline Diameters and Materials Options

The existing 30-inch-diameter gravity/force main discharge line is constructed of reinforced concrete pipe. The new effluent discharge piping alternatives considered three different diameter and pipe configurations and several different materials options, which are summarized below.

The following effluent pipeline options were considered:

- A single 48-inch-diameter pipe
- Twin 36-inch-diameter pipes
- Phasing the installation of new pipelines using the existing 30-inch-diameter plus one new 36-inch-diameter pipeline (with the intention of installing an additional 36-inch-diameter pipeline in the future)

Table 4-3 lists several considerations related to redundancy, reliability, the ability to phase the construction and spread costs, and uncertainties associated with each option.

Table 4-3. Pipeline Diameter Alternatives Comparison

Engineering Report for the Phase 5A Project—Columbia River Outfall and Effluent Pipeline

Option	Redundancy	Reliability	Phase-ability	Uncertainties
Single new 48-inch-diameter pipe	None, but could obtain some redundancy by tying in the existing 30-inch-diameter pipe. Under that scenario would have 34 mgd of redundant flow (assumes velocity of 11 ft/sec is acceptable).	New main pipe (reliability high). Older (44 years) if existing 30-inch-diameter is also utilized as backup (less reliable).	None, all pipe installed at the same time.	Would likely eliminate HDD option for river and railroad crossings due to pipe size.

Table 4-3. Pipeline Diameter Alternatives Comparison*Engineering Report for the Phase 5A Project—Columbia River Outfall and Effluent Pipeline*

Option	Redundancy	Reliability	Phase-ability	Uncertainties
Two new 36-inch-diameter pipes	Each 36-inch-diameter pipe provides redundancy up to a flow of 36 mgd. Connecting existing 30-inch-diameter pipe back in provides redundancy up to 72 mgd with one line out of service.	Two new pipes, reliability is high.	None, all pipe installed at the same time.	Cost may be 20 to 30 percent greater than for a single 48-inch-diameter for most reaches of the project
One new 36-inch-diameter pipe and existing 30-inch-diameter pipe	None, but do have a redundancy up to a flow of approximately 34 mgd (largest line out of service).	One new pipe with high reliability, lesser reliability with existing 30-inch-diameter pipe.	Allows for phasing in a second 36-inch-diameter pipe at a later date.	Condition of existing 30-inch-diameter pipe.

Based on the advantages and disadvantages of each option, a single 48-inch-diameter pipe was selected as the preferred alternative. The reliability would be high and the cost evaluations show that this would be the least costly alternative.

The flow velocities for various pipe diameters, phases, and material types are presented in the Table 4-4. Based on the velocities, a 54-inch-diameter pipe appeared to be oversized and a 42-inch-diameter pipe appeared to be undersized. A 48-inch-diameter pipe was selected as the best alternative because it provides a design velocity of 10.2 ft/sec (HDPE) to 8.9 ft/sec (steel) for the Phase 9 peak flow and efficiency over the largest flow range.

Table 4-4. Velocities for Various Pipe Diameters by Phase and Material Type*Engineering Report for the Phase 5A Project—Columbia River Outfall and Effluent Pipeline*

Pipe Material	Nominal Diameter (inches)	Pipe Inside Diameter (inches)	Area (ft ²)	Velocity by Flow Phase (ft/sec)							
				Current 22 mgd	Phase 4 26 mgd	Phase 5 37 mgd	Phase 6 43 mgd	Phase 7 54 mgd	Phase 8 62 mgd	Phase 9 72 mgd	
Steel (CML – ¼-inch wall)	42	42.00	9.6	3.5	4.2	6.0	6.9	8.7	10.0	11.6	
	48	48.00	12.6	2.7	3.2	4.6	5.3	6.7	7.7	8.9	
	54	54.00	15.9	2.1	2.5	3.6	4.2	5.3	6.0	7.0	
HDPE (IPS sizing)	42	39.30	8.4	4.1	4.8	6.8	7.9	9.9	11.4	13.3	
	(DR 32.5)	48	44.90	11.0	3.1	3.7	5.2	6.1	7.6	8.7	10.2
	63 psi working	54	50.50	13.9	2.5	2.9	4.1	4.8	6.0	6.9	8.0
PVC	42	41.76	9.5	3.6	4.2	6.0	7.0	8.8	10.1	11.7	
	(SDR 32.5)	48	47.68	12.4	2.8	3.3	4.6	5.4	6.8	7.8	9.0
	125 psi working	54	54.02	15.9	2.1	2.5	3.6	4.2	5.3	6.0	7.0
Hobas	42	42.86	10.0	3.4	4.0	5.7	6.7	8.4	9.6	11.1	
	(Class 50/46)	48	48.94	13.1	2.6	3.1	4.4	5.1	6.4	7.4	8.5
	50 psi working	54	55.02	16.5	2.1	2.4	3.5	4.0	5.1	5.8	6.8

Table shading depicts increasing velocities with increasing intensity of shading.

CML = cement mortar lined; DR = dimension ratio; HDPE = high-density polyethylene; IPS = iron pipe size; psi = pounds per square inch; PVC = polyvinyl chloride; SDR = standard dimension ratio.

The anticipated cost of materials was obtained from quotes provided by various pipe manufacturers. The material cost for the various materials is provided in Table 4-5-

The estimated cost of materials plus labor and equipment costs is presented in Table 4-5. These costs are for the long, relatively straight portions of the alignment, and would not apply to the stream crossings or railroad crossing. The costs for HDPE, fiberglass, and PVC pipe (i.e., the lighter weight materials) include the cost of concrete collars at 20-foot spacing. The collars may be necessary to provide weight to resist buoyancy of an empty pipe in areas of shallow cover. The need for the collars will be evaluated more closely during final design.

Table 4-5. Anticipated Pipe Material and Labor Cost

Engineering Report for the Phase 5A Project—Columbia River Outfall and Effluent Pipeline

Pipe Material	Discussion	Material Cost (\$/foot)	Labor and Equipment - Direct Cost (\$/foot)	Total Direct Cost
Steel with rubber gasket joints, cement mortar lining, tape coating with mortar overcoat	In locations with thrust forces, joints would be welded	\$243	\$257	\$500
Steel with welded joints, cement mortar lining, tape coating with mortar overcoat	Better seismic resilience, higher cost due to labor for welding	\$199	\$389	\$588
HDPE (DR 32.5) 63 psi working	Requires large machine for joint fusion, requires long lengths of open trench, requires collars to prevent buoyancy in areas with shallow cover	\$121 \$129 \$140	\$293	\$433
Fiberglass (Hobas or Flowtite) Class 50/46	Joints would be couplings, would require thrust blocks, requires collars	\$192	\$296	\$488
PVC (SDR 32.5) 125 psi working	Joints would be bell & spigot, would require thrust blocks or restrained couplings, 48-inch-diameter PVC does not have a long history of use, would require collars	\$132	\$313	\$445

Notes:

1. Assumes 48-inch-diameter pipe with 5 feet of cover.
2. HDPE pipe - assumed 250 feet of open pipe trench and stringing of pipe. Assumed 50-foot pipe lengths.
3. Concrete Anchor Collar - one per 20 linear feet. Used on HDPE, PVC, fiberglass.

Based on the cost comparison and history of use, steel pipe and HDPE pipe were selected as the preferred materials. Both materials have a long history of use and the estimated costs are considered reasonable. Allowing bids on alternate materials should provide for competitive bids and result in lower project costs.

4.3.2 Reach 1: SCTP to Salmon Creek

Reach 1 of the effluent pipe alignment begins at the connection to the SCTP, crosses the BNSF railroad, and continues across Salmon Creek onto Curtis Lake Ranch property (Station 81+94 to 68+50 in the 30 percent design drawings provided at the end of Section 5).

BNSF Railway Company requires the pipe to be installed in a steel casing for the width of the railroad right-of-way, roughly perpendicular to the tracks and at least 150 feet from the railroad bridge abutment. The effluent pipeline construction alternatives include trenchless construction, open cut construction, and a combination of both. The railroad and Salmon Creek crossing alternatives are briefly described below and trenchless crossing alternatives are described in detail in the Trenchless Crossing Technical Memorandum in Appendix H. Several trenchless methods were considered to complete the

crossing but only two were retained: auger boring and microtunneling (see Appendix H for additional information about other alternatives considered). The two trenchless combinations include auger boring of BNSF railroad with open cut of Salmon Creek and microtunneling in a single crossing under BNSF railroad and Salmon Creek. In addition, an open cut installation under the existing railroad bridge and through Salmon Creek were considered.

4.3.2.1 Open Cut Installation under the Existing Railroad Bridge and through Salmon Creek

For this construction technique, the section of pipe from the effluent pump station to the east side of the BNSF railroad right-of-way would parallel the existing outfall alignment, maintaining a minimum of 20 feet of separation to provide protection from damage occurring during construction of the new effluent pipeline. At the railroad right-of-way, the pipeline separation would be reduced to allow construction of the new effluent pipeline within the narrow corridor beneath the BNSF bridge. There is only 15 feet between the existing outfall pipeline and the railroad bridge abutment, allowing enough area for only a single 48-inch-diameter pipeline in a 60-inch casing (required by BNSF) to be constructed within the BNSF railroad right-of-way. The BNSF bridge will impact the overhead construction area, limiting the equipment that can be utilized to install this segment. These horizontal and overhead constraints need to be clearly defined with BNSF input during final design. Consequently, a temporary bridge would be constructed over Salmon Creek to allow equipment access via the Curtis Lake Ranch property. The temporary bridge would require a bridge permit from the U.S. Coast Guard, would need to maintain vessel navigation, and would need to be removed upon project completion.

The open cut section for the Salmon Creek crossing would parallel the existing pipeline, maintaining 20 feet of separation for protection. This portion of pipe would be constructed in phases utilizing cofferdams, dewatering, and sediment controls. The pipeline would be constructed below the existing grade of Salmon Creek and capped to ensure that erosion of the streambed does not uncover the effluent pipeline. The open cut would temporarily impact Salmon Creek wetlands.

This alternative was later eliminated after discussions with BNSF confirmed a mandatory 150-foot requirement from the railroad abutment.

4.3.2.2 Auger Bore under the Railroad and Open Cut through Salmon Creek

This alternative uses auger boring to install the required steel casing under the railroad tracks, a crossing length of about 513 feet, paired with an open cut crossing of Salmon Creek, which is a crossing length of about 375 feet. This auger boring length is beyond the typical crossing length for this trenchless construction method; however, local contractors have successfully installed these at longer lengths. The open cut portion would be completed by using a cofferdam to complete construction within half of the creek at a time. Environmental permits would be required to excavate and fill within Salmon Creek.

Auger boring in saturated sands carries a high risk of flooding the casing with flowing sand, which may cause the auger boring equipment to become stuck underground. Rescue would require significant dewatering for personnel entry into the tunnel (high safety risk) or for a rescue shaft, which would be challenging because of the presence of the railroad embankment. If equipment retrieval were not possible, it would be abandoned in place and a new crossing would have to be attempted. The technique of carrying a soil plug at the leading end of the casing is recommended to provide a barrier to reduce the risk of unanticipated flowing sands entering the casing. As noted previously, dewatering is likely required at the east end of the crossing. As long as an adequate soil plug is maintained, issues are not anticipated with the presence of a limited zone of soft silts on the west side of the embankment.

Given access restrictions to the west side of the BNSF embankment, it may be preferable to install the casing under the railroad in a downward direction from the east side. There are no tunneling machines to recover with the auger boring method. The downside to this is that any groundwater encountered would not drain from the leading end of the casing; however, the predominantly silty materials are low

in plasticity and should not clog the augers. Additional advantages and limitations for this construction approach are presented in Appendix H.

This alternative would require the use of a temporary trestle to cross Salmon Creek to install the cofferdam, excavate the soils, place the pipe, and backfill the pipe. The temporary bridge would require a bridge permit from the U.S. Coast Guard, would need to maintain vessel navigation, and would need to be removed upon project completion. The pipeline would be constructed below the existing grade of Salmon Creek and capped to ensure that erosion of the streambed does not uncover the effluent pipeline. The open cut would temporarily impact Salmon Creek wetlands.

4.3.2.3 Microtunneling under the Railroad and Salmon Creek in One Drive

Microtunneling is an ideal trenchless construction method for conditions below the groundwater table because it is a pressurized system. It is also capable of mining the entire length of the combined crossing below the BNSF railroad and Salmon Creek in a single drive. The tunnel length of a single microtunneled crossing would be approximately 900 feet, crossing the railroad at approximately a 90-degree angle from the right bank of Salmon Creek to the SCTP shaft.

The soil in the proposed tunnel zone at Salmon Creek, on the west side of the crossing, is too soft and loose to support the weight of a microtunnel boring machine (MTBM). In this material, a microtunneled crossing is not feasible. However, if the proposed pipeline were lowered approximately 10 feet, the crossing could be completed in the loose to medium dense and firm material, which could provide the support required for the weight of the microtunneling equipment. However, this change would result in a deeper shaft on the west side of the single crossing, which in turn increases construction costs for the additional and deeper excavations. Advantages and limitations for this construction approach are presented in Appendix H.

4.3.2.4 Rank Order and Value Comparison

Three alternative construction techniques/routes, depicted in Figure 4-5, were evaluated for this crossing. Planning level cost estimates for each technique/route were developed for this segment and are included below for comparison of alternatives:

- **Baseline Alternative (Route 3).** This baseline alternative assumes an auger bore or pipe ram for the railroad crossing and an open cut construction approach for the Salmon Creek crossing (\$1.1 million).
- **Baseline + Trenchless (Route 2).** This alternative assumes a trenchless crossing of both Salmon Creek and the BNSF railroad using microtunneling for the entire length (\$4.9 million).
- **Baseline + Open Cut (Route 1).** This alternative uses a parallel route to the existing route effluent pipeline route and assumes open cut construction under the railroad bridge (\$2.5 million).

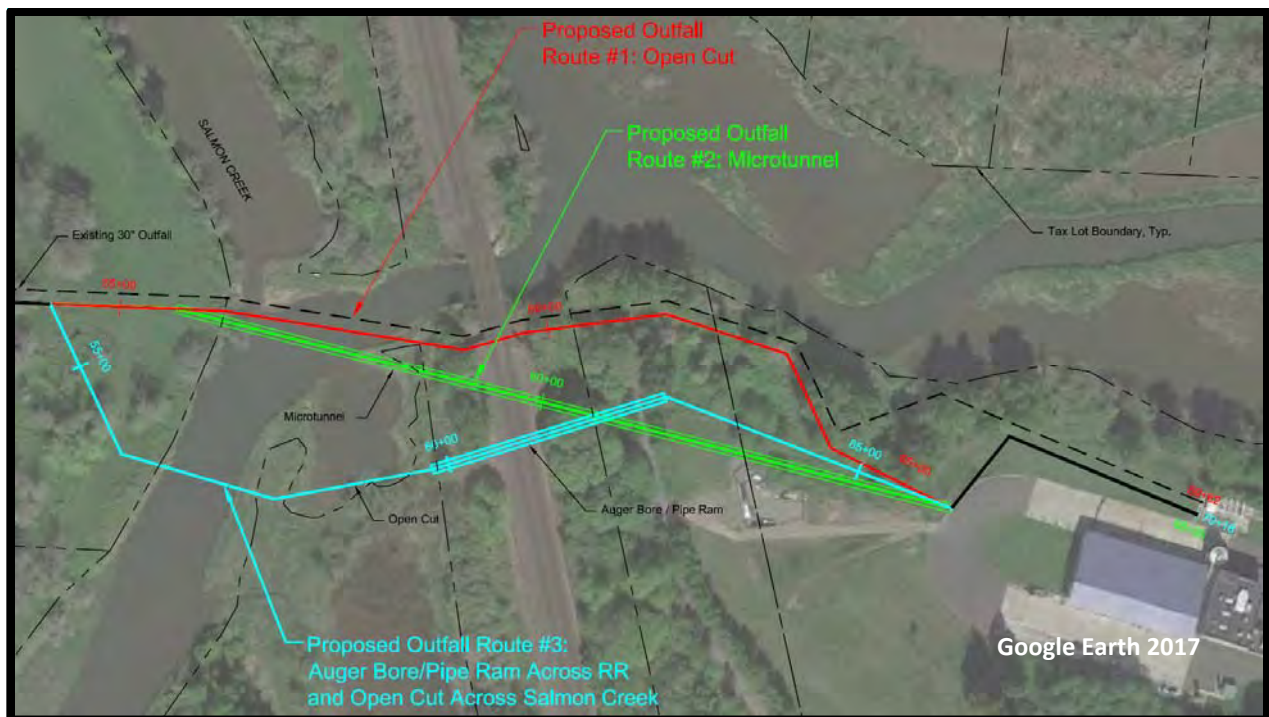


Figure 4-5. Salmon Creek and BNSF Railroad Crossing Alternatives
 Engineering Report for the Phase 5A Project—Columbia River Outfall and Effluent Pipeline

The construction technique/route alternatives evaluation uses specific criteria and goals outlined in Section 4.1.11 defined by the CWA Section 404(b)(1) Guidelines. These criteria and goals account for cost, risk, constructability, and environmental criteria. Scoring for each option is presented in Table 4-6 and allows for comparison and ranking of each construction technique/route in the reach with an individual score, ranging from -5 to +5, for each goal and an overall score for the construction technique/route. Results show that the three construction techniques/routes are similar in their total score.

Route 1 has the highest (most favorable) score but was eliminated after discussions with BNSF confirmed a mandatory 150-foot requirement from the railroad abutment. Route 2 has the next most favorable score but recent geotechnical investigations confirmed that low blow count soils would require a deeper profile for a successful microtunnel crossing approach. The deeper microtunnel profile would further increase the cost for this construction method and potentially create additional environmental impacts with deeper shafts on both ends of the crossing. Route 3 was selected for this reach as it provides a practicable and permittable alternative while providing a the most cost- effective solution for this challenging reach of the project. Further refinements to Route 3 alignment were made after additional archeological and geotechnical field investigations were completed in 2017. These refinements consist of straightening the alignment over the entire BNSF railroad and Salmon Creek crossing while maintaining 150-ft offset from the railroad abutment, avoiding the archeological area adjacent to the railroad, selecting the best location for an auger bore launching shaft and allowing for contractors with microtunneling equipment to bid on the project should they be able to provide a low-cost bid. The final recommended Route 3 alignment is presented in Section 5.

Table 4-6. List of Non-Cost Evaluation Criteria and Goals*Engineering Report for the Phase 5A Project—Columbia River Outfall and Effluent Pipeline*

Criteria	Goals	Baseline Alternative (Route 3)	Baseline+ Trenchless (Route 2)	Baseline +Open Cut (Route 1)
Location	Avoids disruption of surface hydrology	-2	2	-1
	Favors previously used sites	0	3	3
	Minimizes the extent of discharge plume	4	4	4
	Avoids sites with unique habitat or other value	-2	0	-1
	Minimizes impacts associated with future maintenance activities	3	3	3
Timing	Construction during low flow	3	3	3
	Construction during low fish presence	-1	2	-1
	Construction during low groundwater conditions	3	3	3
Technology	Uses appropriate equipment (e.g., low ground pressure)	3	3	3
	Minimizes footprint	0	-1	1
	Creates ecological uplift	2	0	4
	Reduces risk of failure due to catastrophic events	3	3	3
	Proactively plans for compliance with increasingly stringent regulations	2	2	2
	Provides flexibility to respond to future land use and economic development	4	4	4
Work Method	Maintains natural substrate contours (e.g., avoids net floodplain fills)	5	5	5
	Clearing outside migratory bird nesting season	3	3	3
Logistics	Minimizes impact to treatment facilities during construction	2	-1	2
	Minimizes impact to property owners	1	1	2
	Minimizes temporary disturbance during construction	3	3	1
Cost	Achieves reasonable life cycle cost	0	-2	1
Total Score		36	40	44

4.3.3 Reach 2: Salmon Creek to Lake River

Reach 2 of the effluent pipe alignment begins on west side of Salmon Creek and continues to the eastern side of Lake River (Station 68+50 to 46+50 in the 30 percent design drawings provided at the end of Section 5). This reach of the effluent pipeline covers approximately 2,200 linear feet. The only alternative evaluated for this reach was open cut with direct burial. Tunneling or other methods were not deemed cost efficient. The alignment will parallel the existing outfall, maintaining a 20-foot separation. Based on the soil borings, it appears that the native material could be suitable for backfill

above the pipe zone, limiting the amount of hauling of spoils required. The alignment will limit wetland impacts to only unavoidable crossings of Curtis Lake and an unnamed slough. The dewatering requirements will be greatly influenced by the construction season, but this reach could be constructed any time of the year with proper dewatering in place.

While the actual installation of the pipeline does not utilize a specialty construction technique, except perhaps a trench box for the wetland crossing, this reach has limited accessibility. There are four ways to mobilize equipment to the west side of Salmon Creek as follows:

1. **Private At-Grade Railroad Crossing.** This crossing is utilized by the land owner (Curtis Lake Ranch) to move large farming equipment across the tracks. To use this crossing, Curtis Lake Ranch is required to notify the BNSF Railway Company in advance of the planned crossing. The use of this crossing would need to be negotiated with the land owner and BNSF.
2. **Private Tunnel Below the Railroad.** This tunnel is adequate to move small farm vehicles and livestock onto and away from the property. However, this tunnel lacks an opening large enough to pass the sizes of trucks and equipment required to construct this reach. Any use of this tunnel would need to be negotiated with the land owner.
3. **Barge.** The heavy equipment could be loaded onto a flat-bottom barge, floated from the Columbia River up Lake River, and offloaded to the project site. At this time, it is assumed that Lake River would provide adequate depth to float a barge to the project site, but this has not been verified with survey beyond project limits.
4. **Temporary Bridge.** A temporary bridge could be constructed over Lake River, which could allow equipment access via Lower River Road, then along the pipeline construction easement at the New Columbia Garden property. The temporary bridge requires a bridge permit from the U.S. Coast Guard, would need to maintain vessel navigation, and would need to be removed upon project completion.

4.3.4 Reach 3: Lake River Crossing

Reach 3 of the effluent pipe alignment begins on the eastern side of Lake River and continues across Lake River (Station 46+50 to 42+00 in the 30 percent design drawings provided at the end of Section 5). The alignment includes a “jog” away from existing pipeline to protect existing 30-inch-diameter effluent pipe during construction.

Trenchless and open cut crossing alternatives were evaluated for Lake River. Trenchless alternatives included HDD, direct pipe, and microtunneling. Construction approaches, challenges, and costs for these alternatives were compared. A site meeting with WDFW on August 15, 2017, also helped highlight the permitting challenges with some of the construction approaches.

Horizontal Directional Drilling

The Lake River crossing will be below the groundwater table, so a pressurized-face trenchless construction method is possible. HDD can be used to directly install an HDPE or PVC pipe from the surface without a casing (Refer to Figure 1 in Appendix H for schematic representation of HDD process).

HDD is typically a surface-launched process where a small-diameter pilot borehole is drilled along the design alignment and stabilized by filling it with drilling mud. The pilot borehole is enlarged by successive reaming passes, while keeping the borehole filled with drilling mud. When the borehole diameter is approximately 12 inches larger than the pipe or 1.5 times the outside diameter (OD) of the pipe, the pipe is pulled into the borehole, displacing most of the drilling mud. Pipelines up to 54 inches in diameter have been installed using HDD. Shafts are not typically required because HDD bores are installed along a sweeping vertical curve (concave up) from surface to surface. Dewatering is also typically not required. HDD crossing lengths are a function of the allowable bending radius for the pipe

material being installed. The minimum bend radii for HDPE pipe is on the order of 50 to 100 times the OD of the pipe; however, the steel drill pipe usually controls the design, with a minimum design radius of 1,200 times the OD of the steel drill pipe. HDD is a steerable tunneling method; however, it is less-accurate than other steerable trenchless methods. HDD can be used in a wide range of soil conditions.

Concerns with using HDD for this crossing include the length of the required bore, which will be significantly longer than the distance required to cross Lake River, and the diameter of the pipe required for an inside diameter of 48 inches, which will be on the upper end of the comfortable range for HDD installation. Another significant concern is frac-out of the drilling fluid to the ground surface or into Lake River. In a site meeting with WDFW (August 2017), WDFW staff expressed concerns about the possibility of frac-out because the substrate is loose and unconfined and because the large pipe is at the limits of operability. While there are several approaches to mitigating the risk of frac-out, there are significant environmental concerns associated with this risk.

Because of the long bend radius required under Salmon Creek and the frac-out risk concerns, HDD was dropped as a construction method.

Direct Pipe under Lake River

Direct pipe installation can be used for this crossing. This is a pressurized-face method; however, slurry pressures are lower than those for HDD, reducing risk of frac-out into Lake River. Using direct pipe, the pipeline would be directly installed from either the east or west side of Lake River from surface to surface. Dewatering would not be required; however, the method requires the use of a steel casing, which is not considered necessary and adds additional cost to the crossing.

Microtunnel under Lake River

Microtunneling, as described above for Reach 1, can be used for this crossing. Microtunneling is also a pressurized-face method, but unlike HDD and direct pipe, is installed as a horizontal alignment between two shafts. Launching and receiving shafts would be located on the east and west sides of Lake River, and a steel casing would be installed with microtunneling techniques. A steel casing with a minimum diameter of 60 inches would be installed at this location to accommodate a 48-inch-diameter carrier pipe. For a 36-inch-diameter carrier pipe, a minimum 48-inch-diameter steel casing would be required. Dewatering at the shafts would be required for this construction method.

Open Cut through Lake River

Open cut of Lake River could be achieved with several different open cut construction methods: wet construction, use of a flume or dike, and pump construction with full isolation or a cofferdam approach. WDFW staff confirmed that they were not likely to permit a wet excavation construction because it would be difficult to control turbidity given muddy bottom. A flume or a dike and pump construction method with full width isolation was also discussed, but determined to be inconsistent with WDFW's preference for a construction approach that would keep a portion of the channel open for fish passage and vessel passage during all phases of construction.

The open cut construction through Lake River would consist of a two-phase construction utilizing cofferdams, significant dewatering, and sediment controls. Sheet pile driving would likely be used and hydroacoustic impacts could be avoided if vibratory or jacking methods were used to drive piles. Pile depth might need to be deep to reduce dewatering and grouting would be used to create a hydraulic seal.

4.3.5 Reach 4: Lake River to the Columbia River Onshore Angle Point

Reach 4 of the effluent pipe alignment begins on the western side of Lake River (Station 42+00) and continues past the junction with the existing outfall pipe (Station 21+00) to the Columbia River onshore angle point (Station 13+00) as shown in the 30 percent design drawings provided at the end of Section

5). This reach of the effluent pipeline covers approximately 2,100 linear feet. The construction method for this reach is open cut with direct burial. The alignment will parallel the existing outfall, maintaining a 20-foot separation. Based on the soil boring in this area, it appears that the native material could be suitable for backfill above the pipe zone, limiting the amount of hauling of spoils required. The final alignment and trench box construction will minimize the impacts to the wetlands associated with Round Lake. Round Lake water elevation is influenced by seasonal Columbia River stage elevations and is also tidally influenced by the ebb and flood tides on the Columbia River. The time of year this reach is constructed will greatly impact the size and proximity of the proposed pipeline. As is the case in the Reach 2 between Salmon Creek and Lake River, the dewatering requirements will be greatly influenced by the construction season, but this reach could be constructed any time of the year with proper dewatering in place. Coordination with the proposed Round Lake Conservation Bank will be required.

4.3.6 Reach 5: Onshore Angle Point to Outfall Diffuser Terminus in the Columbia River

Reach 5 of the effluent pipe alignment begins at the junction with the existing outfall pipe at the outfall pipe angle point (Station 13+00) and extends offshore to the outfall diffuser terminus (Station 9+70). Refer to the 30 percent design drawings at the end of Section 5. Open cut, underwater construction was the only solution evaluated. Any type of tunneling method would not be practicable for this portion of the construction. Construction methods and limitations were discussed with specialty marine contractors. Recommendations included open cut, underwater construction, and keeping pipe depth to a maximum of 10 feet because of the limitations of keeping the trench manageable and open during underwater trenching. This depth is acceptable based on the understanding of possible future erosion in the trenched areas, which is not expected to erode depth of cover, but will mainly have effects on bank erosion as described elsewhere.

4.4 River Outfall and Diffuser Alternatives

4.4.1 Evaluation of Outfall Options in River

The iterative process of identifying, screening, and evaluating new outfall options was initiated by assessing potential diffuser or discharge sites that meet design criteria. The outfall diffuser design criteria are presented in Section 4.1.3; these include diffuser design configuration with discharge depth and port size and spacing to provide dilution performance to meet water quality standards, locate diffuser at 40- to 50-foot depth at site with stable bedforms, provide structural stability for riverbed conditions, design to address shoreline bank erosion along the Columbia River, and provide long-term hydraulic capacity.

Initial screening-level assessments of outfall options for the replacement SCTP outfall and diffuser evaluated potential diffuser sites on the Columbia River both north and south of the existing SCTP outfall diffuser. Four preliminary outfall diffuser site options were identified, three were located north (downriver) of the Willow Pile Dike (RM 95.85) and one large site located south (upriver) of the existing SCTP outfall and the Willow Pile Dike. All potential diffuser sites were located downslope of the nearshore shallow shelf and in the range of 40- to 50-foot water depths at low river stage. The two northern-most diffuser sites were eliminated since they did not provide any benefits over the two sites closest to the existing SCTP outfall and they required longer effluent pipeline routes to reach. The two outfall diffuser sites selected for further evaluation are shown in Figure 4-6.

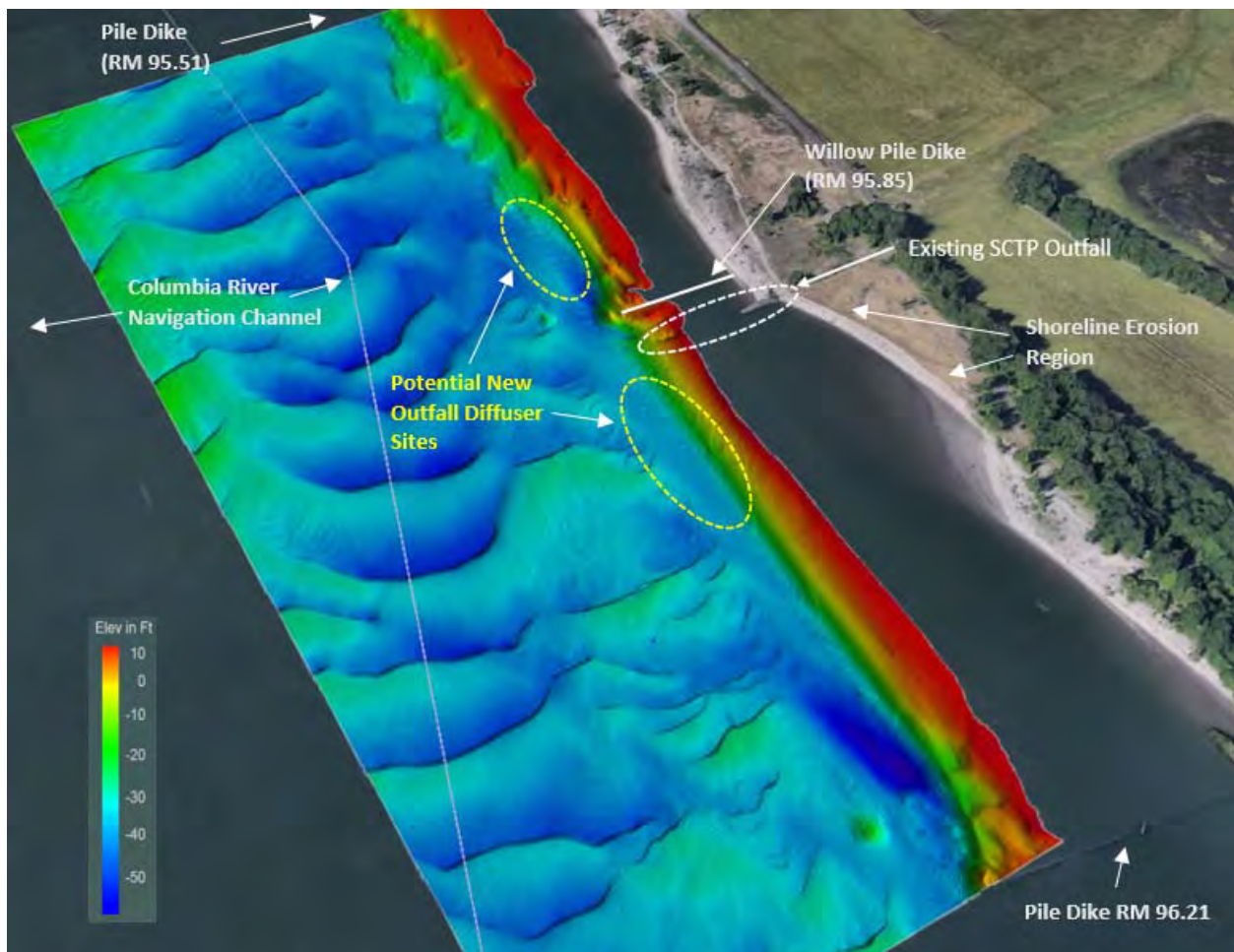


Figure 4-6. Overview of Potential New SCTP Outfall Diffuser Sites on the Columbia River
Engineering Report for the Phase 5A Project—Columbia River Outfall and Effluent Pipeline

The 2015 field data collections for the design of the replacement SCTP outfall and diffuser included extensive current measurements and discharge plume transport simulations (drogue tracking) to represent the two potential diffuser sites located north and south of the Willow Pile Dike (refer to Section 2 for details). These two potential replacement outfall routes and diffuser sites are shown in Figure 4-7.

The potential north diffuser site is shown in Figure 4-7 as a 100-foot by 100-foot box. The potential north diffuser site and outfall route have riverbed features that could pose problems in construction or long-term diffuser function, including unknown outcrop or rock pile features along the outfall route, and a large scour area downstream of the end of the Willow Pile Dike. The outcrops or rock piles would pose a challenge to cut and cover trenching the outfall installation and would require additional geophysical and geotechnical investigations to resolve.

The potential south diffuser site is shown in Figure 4-7 as a 200-foot wide by 100-foot long box. The potential outfall route is shown at 200 feet south of the existing SCTP outfall alignment. The potential south diffuser site and outfall route does not show any riverbed features that could pose problems in construction or long-term diffuser function, and the potential area to site the outfall and diffuser is larger. The riverbed along the south outfall route and diffuser site is uniform sands that are conducive to open trench construction.

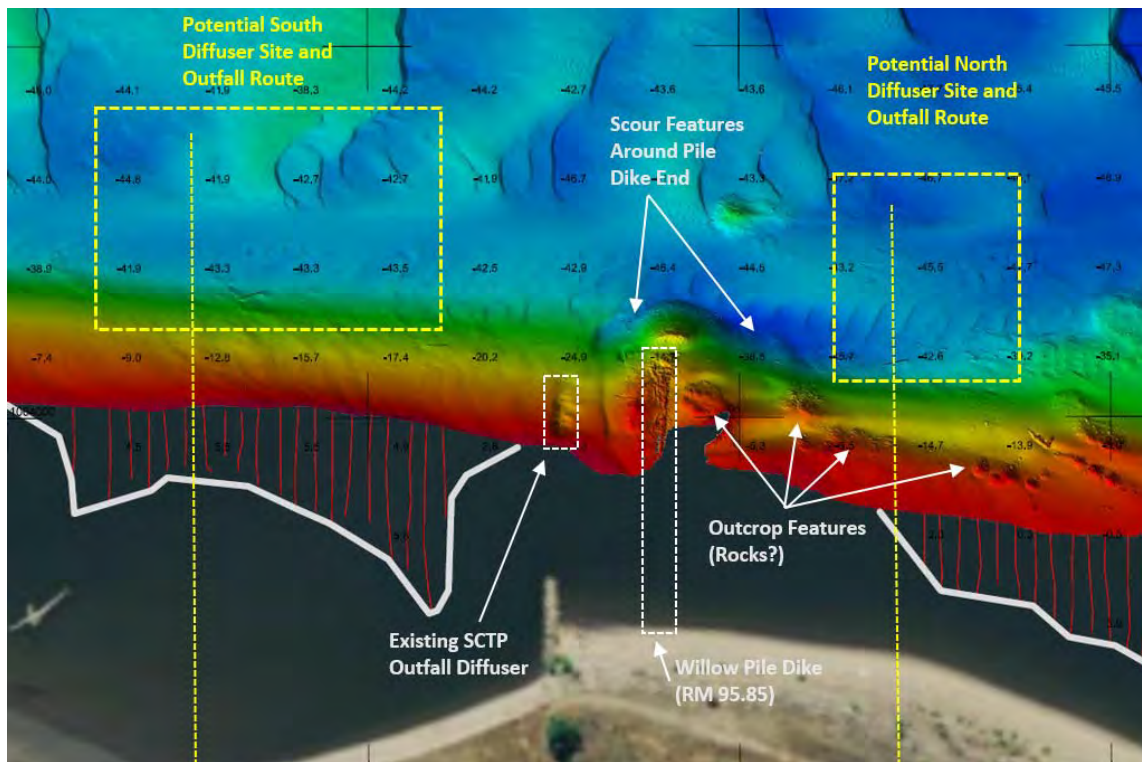


Figure 4-7. Locations of Potential New SCTP Outfall Routes and Diffuser Sites on the Columbia River Near RM 96
 Engineering Report for the Phase 5A Project—Columbia River Outfall and Effluent Pipeline

Based on the results of the 2015 field data collections, detailed evaluations of the riverbed bathymetry features at the two potential diffuser sites and outfall routes, and landowner preference, the diffuser site south of the existing SCTP outfall and Willow Pile Dike was selected to advance into design. The selected outfall route is located 200 feet south and parallel to the existing SCTP outfall (see Figure 4-8), and this separation distance was selected to allow for the open trench construction of the new outfall and staging of construction barges and cranes to avoid impacts to the functioning of the existing SCTP outfall diffuser during construction.

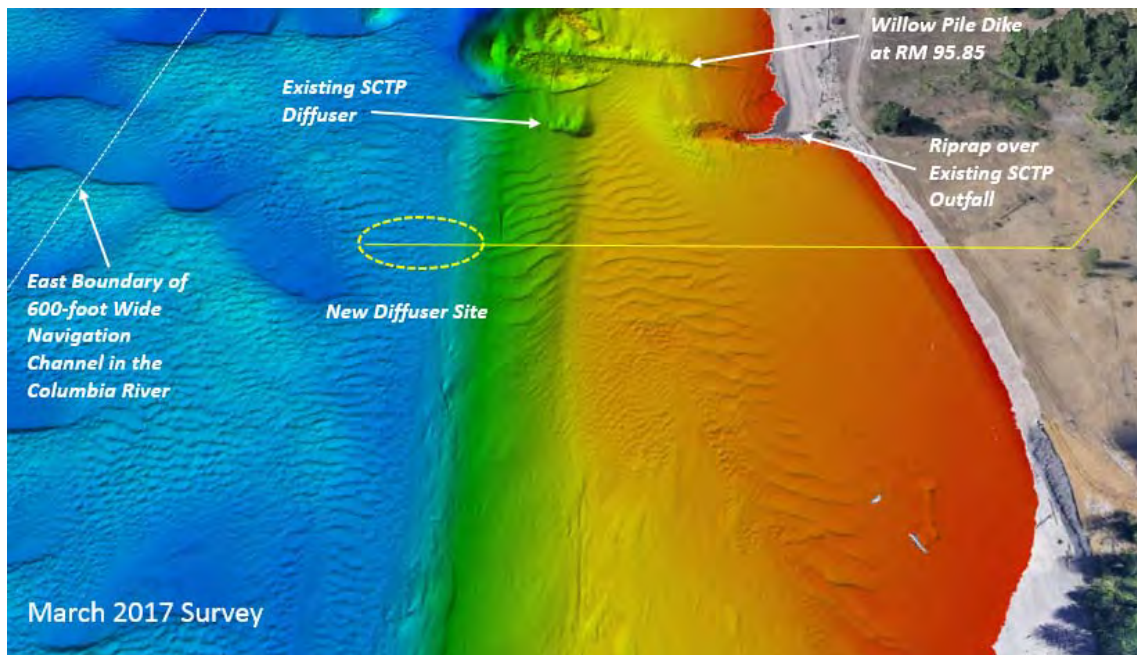


Figure 4-8. Replacement SCTP Outfall Route and Diffuser Site on the Columbia River Near RM 96
 Engineering Report for the Phase 5A Project—Columbia River Outfall and Effluent Pipeline

The selected replacement outfall diffuser site is approximately 200 feet south (upriver) of the existing SCTP outfall, more than 300 feet from the nearest Columbia River navigation channel, and outside of any designated commercial vessel anchorage area (south of Pile Dike 96.21). Figure 4-9 illustrates the new SCTP outfall diffuser site relative to the federal navigation channel and the designated commercial vessel anchorage area.

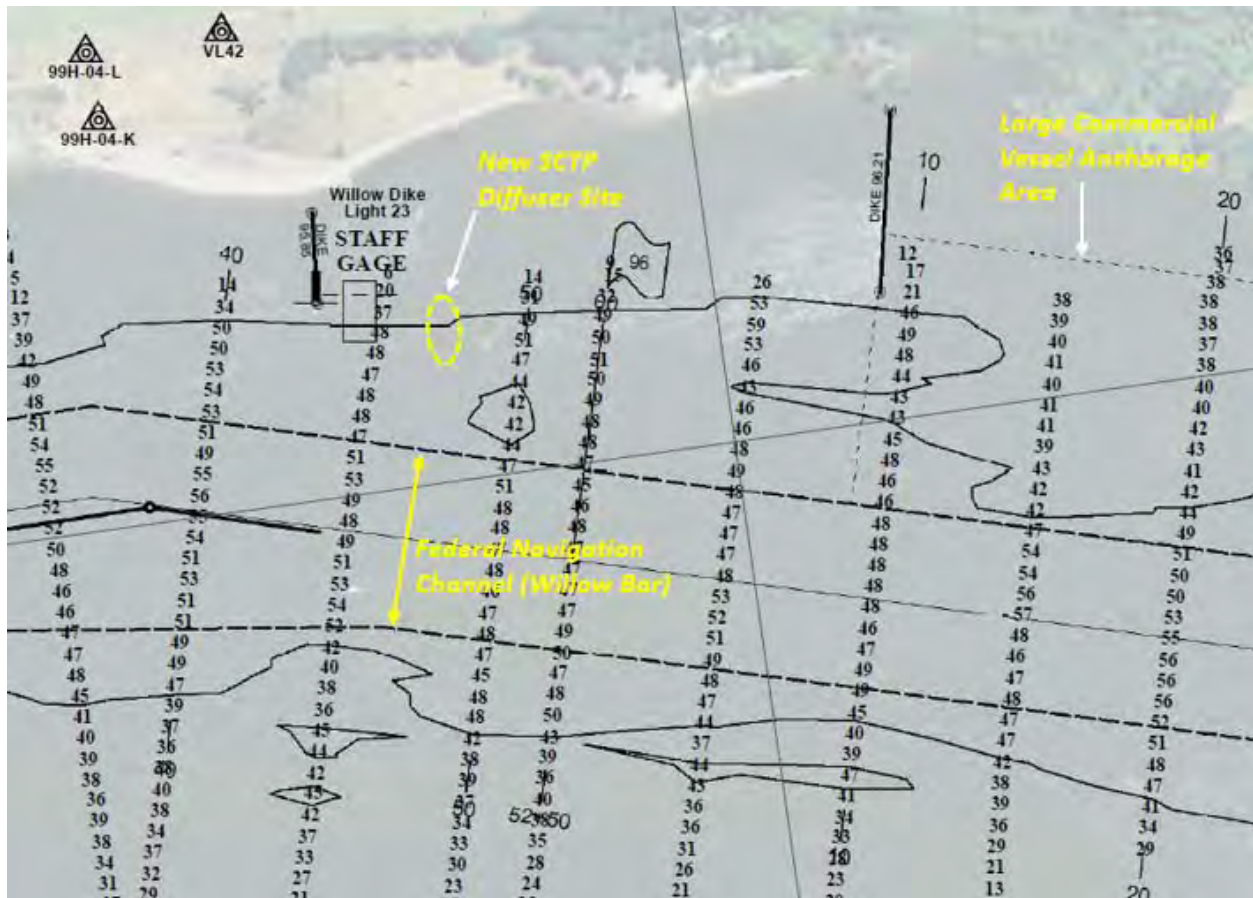


Figure 4-9. Location of New SCTP Outfall Diffuser Site on the Columbia River Near RM 96 Relative to Designated Navigation Channel and Anchorage Areas

Source: USACE Willow Bar Condition Survey, December 2014
Engineering Report for the Phase 5A Project—Columbia River Outfall and Effluent Pipeline

To address the design criteria of structural stability and long-term hydraulic capacity, the entire length of the outfall and diffuser will be a buried 48-inch concrete-coated steel pipe, and the outfall diffuser section will be buried with thick-walled vertical steel risers fitted with elastomeric check valve ports. The number, size, spacing, and depth of the diffuser ports is developed in the following section based on dilution modeling, as well as the results of the river bedform evaluation.

To address the design criteria of structural stability the outfall diffuser section will be pile-supported and the buried outfall pipe in the river will have multiple ball joints to allow deflection induced by settlement. To address river bank erosion, the outfall pipe will be buried deep and the most vulnerable portion of the pipe will be bedded in quarry rock and covered by an articulated concrete revetment mat.

The river outfall and diffuser pipe will be constructed in an open cut trench that will necessitate approximately 4 to 1 slopes due to the sands that constitute the entire route and the tidal-reversing river currents at the site. Marine construction equipment will need to stage on the river south of the outfall route and either north or south of Pile Dike 96.21. A navigation marker will need to be constructed at 40 to 50 feet offshore (west) of the outfall diffuser terminus to provide protection of the

outfall diffuser from errant tug and barge traffic that is outside of the defined navigation channel (refer to Section 4.1.7, Navigation Marker).

4.4.2 Diffuser Alternatives Analysis

Diffuser configurations were reviewed as part of the identification and evaluation of outfall diffuser alternatives that meet the dilution performance design criteria. These diffuser configurations also need to provide structural stability and incorporate the bedform height variability at the site. The outfall diffuser design criteria presented in Section 4.1.3 include diffuser configurations with varying discharge depth, port size, and port spacing to provide dilution performance to meet water quality standards. Based on the design criteria, eight outfall diffuser configurations were identified and evaluated for port velocities, head loss, and dilution performance.

The eight outfall diffuser alternatives that were developed and evaluated are summarized below:

- Alternative 1: 7, 24-inch elastomeric check valve ports on 7 risers at 20-foot spacing
- Alternative 2: 8, 20-inch elastomeric check valve ports on 8 risers at 20-foot spacing
- Alternative 3: 10, 20-inch elastomeric check valve ports on 10 risers at 18-foot spacing
- Alternative 4: 10, 16-inch elastomeric check valve ports on 10 risers at 16-foot spacing
- Alternative 5: 14, 18-inch elastomeric check valve ports on 7 risers at 20-foot spacing
- Alternative 6: 16, 16-inch elastomeric check valve ports on 8 risers at 18-foot spacing
- Alternative 7: 20, 12-inch elastomeric check valve ports on 10 risers at 18-foot spacing
- Alternative 8: 20, 14-inch elastomeric check valve ports on 10 risers at 18-foot spacing

Based on the evaluations of these eight alternative diffuser configurations, Alternative 4 (10, 16-inch elastomeric check valves on 10 risers at 16-foot spacing) was selected as the preferred diffuser alternative based on dilution and hydraulic modeling results. This optimized diffuser configuration will yield approximately 1.5-foot head loss from 10 ports, with peak discharge velocity of 12.7 fps at a peak hour effluent flow (at buildout) of 72 mgd. Dilution modeling analyses of the selected diffuser configuration is presented in the following section in detail.

4.4.2.1 Outfall Dilution Modeling Development

Dilution modeling was used to predict dilution performance of the new SCTP outfall diffuser under critical (worst-case) receiving water conditions and for the range of receiving water conditions expected at the discharge site. Outfall dilution modeling was conducted for specific effluent flows and temperatures and critical receiving water conditions of temperatures, discharge depth, tidal direction, and current velocities in accordance with guidance provided in Chapters 6 and 7 and Appendix C of the Program Permit Writer's Manual (Ecology, 2015).

The specific inputs of effluent flow and temperature and receiving water conditions are defined in the following sections. The modeling conditions that produce the lowest predicted dilutions identify the site-specific critical conditions for the discharge.

River Conditions for Modeling

River flow and stage elevation statistics and calculated river channel parameters for the various discharge scenarios used in dilution modeling were developed using the Bentley® FlowMaster® V8i program (Bentley Systems, 2009). FlowMaster® is a hydraulic analysis program approved by the Federal Emergency Management Agency for the design and analysis of open and irregularly-shaped channels, and other applications.

Water surface elevations (WSEs), cross-sectional flow area, channel average velocity, channel top width, and channel average water depth were calculated for a range of discharge conditions using Manning’s equation within FlowMaster®. Hydraulic model input data include cross-section geometry, longitudinal slope (based on transect data from the NOAA 2009 and Solmar 2015 bathymetric surveys of the river), and Manning’s roughness coefficient. Since the bottom roughness is an important variable in the calculations, these values were estimated to represent both critical low river discharge conditions and high river (wet season) discharge conditions. Average depth was calculated by comparing the WSE predicted by the model to the average submerged elevation of the channel bottom. Aerial photographs from Google Earth and field observations from site visits were used to estimate the slope of the bank above the waterline on the opposite (west) riverbank. Once the calibration was complete, the average velocity in each model scenario was determined by changing discharge rate in the FlowMaster® setup file and assessing average channel depth by comparing WSE to average bottom elevation. Table 4-7 summarizes the FlowMaster results for the Columbia River at RM 96 and includes calculated channel average current velocities based on the river flow and cross-sectional area for the various river stages.

Table 4-7. FlowMaster Results for the Columbia River at the SCTP (RM 96) for Dry and Wet Season, Annual Average, and Field-Measured Discharge Conditions ^a

Engineering Report for Phase 5A Project—Columbia River Outfall and Effluent Pipeline

Columbia River Discharge Condition	River Discharge (cfs) ^b	WSE, feet (NGVD29 datum)	Cross-Sectional Area (square feet)	Channel Average Velocity (ft/sec)	Channel (Top) Width (feet)	Channel Average Depth (feet)	Diffuser Port Depth, Average (feet)
Site Conditions During Summer 2015 Field Measurements							
August 26, 2015 ^c	152,775	+5.9	96,790	1.14	2,501	55.3	45.4
Critical Low River Flow (Dry Season) Conditions							
7Q10 Low Flow	83,506	+3.1	94,712	0.88	2,474	54.4	42.6
Annual Average Conditions (Based on Entire Record Period)							
30Q5 Flow	99,893	+3.9	95,028	1.05	2,487	54.6	43.4
Harmonic Mean	191,106	+7.0	97,778	1.95	2,508	55.7	46.5
Wet Season Conditions (November through April only)							
7Q10 Low Flow- Wet Season	108,766	+4.2	96,219	1.13	2,496	55.0	43.7
7Q90 High Flow – Wet Season	575,000	+21.5	169,450	3.04	3150	76	62.0

^a An estimated river channel slope of 0.000035 (0.18 foot/mile) and a Manning’s roughness coefficient of 0.030 (natural stream-clean) were used as input for the FlowMaster program for low river flows (< 100,000 cfs); an estimated slope of 0.000022 (0.12 foot/mile) and roughness coefficient of 0.041 were used for river flows > 150,000 cfs.

^b Critical design river flows were developed using DFLOW (EPA, 2006).

^c Mean Columbia River discharge at RM 96 during the instrument deployment (August 2015) is based on combined recorded flows for the Columbia River at The Dalles, plus the Hood, Klickitat, White Salmon, Sandy, and Willamette Rivers.

Model Selection

The following dilution models were considered for use in modeling the new SCTP outfall diffuser:

- Visual Plumes, a model interface and file manager with the plume model UM3 (Frick et al., 2003) and DKHW (Baumgartner et al., 1994)

- CORMIX2 (Doneker and Jirka, 2007)

The dilution model selection and approach was developed through numerous screening model runs and reviews with a senior reviewer and modeler. The UM3 and CORMIX2 models were compared using several critical discharge model scenarios. UM3 consistently provided acute and chronic dilution results lower than those from CORMIX2 (i.e., more conservative). For this reason, the Visual Plumes model UM3 was selected to represent dilution factors for the SCTP replacement outfall diffuser. The following provides additional details of these two models and the rationale for the model selection.

Visual Plumes (UM3)

Visual Plumes is an update of the PLUMES modeling system developed by the Environmental Research Division of the EPA. Visual Plumes (VP) is a Windows-based computer application that supersedes the DOS PLUMES (Baumgartner et al., 1994) mixing zone modeling system. VP simulates single and merging submerged plumes in arbitrarily stratified ambient flow and buoyant surface discharges. VP includes the three-dimensional UM3 model based on UM, the DKHW model that is based on UDKHDEN (Muellenhoff et al., 1985), the surface discharge model PDS (Shirazi and Davis, 1974), and the NRFIELD model based on RSB (Roberts et al., 1989a; 1989b; 1989c). The Brooks equations (Brooks, 1960) are retained in VP to simulate far-field plume behavior.

The UM3 model within VP calculates the flux-average dilution, plume trajectory, and trapping level for submerged, buoyant plumes from a single diffuser or single row of multiple diffuser ports in either stagnant or flowing environments. UM3 is a two-dimensional mathematical model that analyzes effluent discharges by tracing the position of the plume through the trajectory path. The model approximates the plume development by using single, one-step integrations over discrete time increments.

The output of the UM3 model runs provide sequential calculation of both dilution and plume distance from the port until initial dilution is completed, and the output were used to predict the dilutions and plume depth at the completion of initial dilution and at various distances downstream of the outfall. As stated previously, the VP interface contains far-field dilution algorithms based on equations developed by Brooks.

CORMIX

The CORMIX mixing zone modeling system, developed for EPA at Cornell University, is a rule-based system that classifies the interaction of discharges and the receiving water (Doneker and Jirka, 2007). The program makes many of the decisions for the model user based on the input parameters that are provided. The system was designed for the non-specialist model user, in order that plume predictions could be made without necessarily having prior knowledge about dilution modeling and mixing processes. The CORMIX models use empirically-derived curve fit equations to make dilution predictions. These equations are selected from length scales that are determined from parameters that are input by the user.

CORMIX 2, which simulates submerged multiport line diffusers, is the CORMIX module that was considered for this application. CORMIX 2 simplifies near-field mixing processes and represents multiport diffusers with a line of individual discharge ports as an “equivalent slot” (line source) of momentum and buoyancy. This approach is used when CORMIX predicts that a hydrodynamically unstable discharge will occur in the near-field. Under these conditions, mixing is based on the plume characteristics *after* the individual ports have merged. For this reason, CORMIX 2 may over-predict the dilution in the near-field under this condition, and which can be a significant drawback to the use of this model that should be recognized. The CORMIX models are, however, an appropriate choice when boundary interactions (e.g., bottom or bank(s)) are an important factor. Given the outfall site’s water depths and the offshore distance from the east river bank, boundary interaction is not an overriding factor in the model selection.

Sensitivity Analysis

Because of the uncertainty associated with model input data, performing a sensitivity analysis on selected input parameters is an important step in determining the range of results that can be expected. Sensitivity analysis also assists in determining which input parameters the model is most sensitive to. When more than one variable at a time is changed, it is difficult to determine which input variable caused the changes in the modeling results. As a result, an important rule-of-thumb when performing sensitivity analyses is to change only one input variable at a time.

Sensitivity analysis generally requires performing two model runs for each parameter to be evaluated. For one of these simulations, the parameter in question should be set to the lowest expected value; the other simulation is set to the highest expected value. The results from these two simulations will then represent how “sensitive” the model is to the parameter that was tested.

Extensive sensitivity model cases were performed to evaluate the optimal configuration for the new SCTP outfall diffuser, specifically—the length, number, and spacings of ports, port angles, and discharge depths. The objective of these sensitivity model runs was to minimize the overall length of the diffuser while still achieving the target dilutions at both the acute and mixing zone boundaries over the entire range of effluent flows (existing conditions through buildout).

The sensitivity modeling was performed initially using only the UM3 model to evaluate the horizontal and vertical angles for the diffuser, in addition to the optimal port spacing. In addition to horizontal and vertical discharge angles of 45 degrees (relative to the ambient current) and 20 degrees (above horizontal), respectively, port spacings of 10, 12, 16, 18, and 20 feet on center were evaluated in sensitivity modeling evaluations to assess outfall diffuser configurations. The UM3 model was selected because it provides more conservative (lower) dilution results at both the AZB and MZB.

Several different multiport diffuser configurations were evaluated to determine the configuration that has been selected: a 144-foot-long diffuser with ten, 16-inch elastomeric, duckbill check valve ports with a port spacing of 16 feet on center. The horizontal and vertical angles of the diffuser ports are 45° and 20°, respectively. This outfall diffuser will have all ports located at water depth of -42.6 feet (NGVD29). The elevation or height of each port above the riverbed will vary slightly depending upon the slope of the bottom and the location along the diffuser.

As determined in the *Columbia River Bedform Analysis for Salmon Creek WWTP - Columbia River Outfall and Effluent Pipeline Project Technical Memorandum* (CH2M, 2016a) (copy provided in Appendix D), bedform heights can vary significantly at this site and need to be taken into account for the outfall design (without compromising the hydraulic performance of the outfall). For this reason, port elevations above the riverbed are assumed to vary from about 3 to 7 feet along the length of the diffuser, with most of the outboard ports having a port elevation of 5 to 6 feet above the riverbed. The port elevation above the riverbed was assumed to be 4.3 feet in the dilution modeling.

Model Comparison

After an optimized diffuser configuration was determined through the sensitivity analysis modeling, the results from the UM3 and CORMIX 2 models were compared directly using a set of cases based on worst-case discharge and ambient conditions. These comparison model cases assumed buildout effluent flows and ambient conditions that provided worst-case predicted dilution factors (7Q10 river flow, flood tide, 10th and 50th percentile current velocities). The results of this model comparison are provided in Table 4-8 at the AZB and MZB distances for the 7Q10 low and 7Q10 high river conditions.

Table 4-8. Comparison of Dilution Factors Between Visual Plumes (UM3) and CORMIX 2 Models Under Worst-Case Effluent and Ambient Conditions at Buildout Effluent Flow Conditions

Engineering Report for Phase 5A Project—Columbia River Outfall and Effluent Pipeline

Description of Model Case	Predicted Dilution Factors by UM3 ^a		Predicted Dilution Factors by CORMIX 2 ^a	
	AZB (24 feet) ^b	MZB (243 feet) ^b	AZB (24 feet) ^b	MZB (243 feet) ^b
7Q10-low river flow, dry season flood tide, 10 th percentile current, DWDM effluent flow at Buildout (37.3 mgd) ^c	16		17	
7Q10-high river flow, wet season, flood tide, 50 th percentile current, WWMM effluent flow at Buildout (38.2 mgd) ^d		71		94

^a Model-predicted (flux-average) dilution factors since the discharge site is subject to tidal-induced flow reversals.

^b AZB is the acute zone boundary; MZB is the mixing zone (chronic) boundary.

^c DWDM is the dry weather daily maximum effluent flow for buildout conditions.

^d WWMM is the wet weather monthly maximum effluent flow for buildout conditions.

As shown in Table 4-8, while the models compare favorably in most instances (particularly for the case assuming 7Q10-low river flow conditions), CORMIX consistently predicts slightly higher dilutions (i.e., less conservative) at both the acute zone and mixing zone boundaries. Therefore, as a conservative approach to the dilution modeling and for the outfall design, the UM3 model was used for all subsequent dilution modeling.

Dilution Model Inputs

The effluent and receiving water characteristics and diffuser configuration are required inputs for modeling dilution and plume behavior. The dilution performance of the new SCTP outfall diffuser was modeled using UM3 and the following model input parameters:

- **Number, diameter, and spacing of discharge ports:** ten, 16-inch diameter elastomeric check valve ports with a spacing of 10 feet on center. *Note: the effective port diameters for elastomeric check valve ports were calculated using the effluent flow rate per port in the ProFlex check valve calculation spreadsheet to determine the port velocities; port velocities were then used to derive the equivalent round port diameter for use in the modeling.*
- **Effluent flow and temperature:** refer to Tables 4-9 through 4-12.
- **Ports horizontal angle:** 45° relative to the ambient current direction.
- **Ports vertical angle:** 20° relative to the water surface.
- **Angle of diffuser axis relative to ambient current direction:** 90°.
- **Discharge depth:** refer to Tables 4-9 through 4-12.
- **Ambient temperature:** 21.1°C (dry season, 90th percentile), 10.7°C (wet season, 90th percentile), and 12.4°C (annual average).
- **Ambient current speeds:** 12.9, 31.1, and 37.6 cm/sec (10th, 50th, and 90th percentile dry season ebb tide, respectively); 4.2, 15.5, and 25.1 cm/sec (10th, 50th, and 90th percentile dry season flood tide, respectively); 17.1 cm/sec (50th percentile, flood tide-7Q10 high, wet season); 32.0 cm/sec (50th percentile, ebb tide-30Q5 flow); 34.4 cm/sec (50th percentile, ebb tide-7Q10 high, wet season); and 59.4 cm/sec (50th percentile, ebb tide-harmonic mean).

The input parameters developed for modeling the new SCTP outfall diffuser are summarized in Tables 4-9 through 4-12.

4.4.2.2 Dilution Modeling of Proposed Outfall Diffuser

Dilution modeling input and analyses were based on the site-specific current and water column measurements collected during the low river flow period in 2015, available effluent flow and temperature data and statistics between 2010 and 2016, and projected effluent flows through buildout. Modeling was conducted to represent discharge scenarios specified in the Permit Writer's Manual (Ecology, 2015).

A total of 44 combinations of discharge and ambient receiving water conditions were modeled to represent the range of critical discharge conditions for the proposed new SCTP outfall diffuser. The model-predicted flux average dilutions are presented at the acute criteria exceedance boundary (AZB) and at the chronic criteria compliance boundary (or MZB) for the various effluent flows and critical receiving water conditions.

A total of 44 discharge scenarios were developed to evaluate dilutions for the selected new SCTP outfall diffuser. For each set of effluent flow scenarios (i.e., existing, 2025, 2040, and buildout), 6 discharge scenarios were developed for the dry season discharge conditions. Seasonal discharge scenarios were developed to match guidance provided in the Permit Writer's Manual (Ecology, 2015) Table 11 (Effluent and Receiving Water Design Conditions for Temperature), Table 12 (Applicable Criteria/Design Conditions), as well as Table C-1 (Point Source Steady-State Flow for Mixing Zone Analysis) and Table C-3 (Critical Ambient Conditions) in Appendix C to the Permit Writer's Manual.

The dry season (May through October) modeling scenarios are summarized as follows:

- **Acute Criteria Conditions:** 7Q10-low river flow and the maximum daily dry weather effluent flow
- **Chronic Criteria Conditions:** 7Q10 low river flow and maximum month dry weather effluent flow
- **Human Health (Non-Carcinogen) Criteria Condition:** 30Q5 low river flow and maximum month dry weather effluent flow
- **Human Health (Carcinogen) Criteria Condition:** harmonic mean river flow and annual average effluent flow

The wet season (November through April) scenarios are summarized as follows:

- **Acute Criteria Condition:** 7Q10-high river flow and the maximum daily wet weather effluent flow
- **Chronic Criteria Condition:** 7Q10-high river flow and the maximum month wet weather effluent flow

These dry and wet season scenarios align with the guidance defined in Tables 11 and 12 of the Permit Writer's Manual (Ecology, 2015) for critical low flow conditions and human health criteria conditions for carcinogens. The matrixes of dry and wet season modeling scenarios, including effluent flows and temperature used, river flow, current velocities, and temperatures, and discharge port depths, are summarized in Tables 4-9 through 4-12.

The record period used to develop effluent flows and effluent temperatures for modeling was January 2010 through April 2016. Peaking factors were developed for dry and wet season conditions to provide flow projections for 2025, 2040, and buildout. A 99th percentile effluent temperature of 23.0°C was calculated to represent *dry weather* conditions, and a 99th percentile effluent temperature of 19.8°C was calculated to represent *wet weather* conditions. These temperatures were used to represent maximum temperature for *acute* water quality criteria. A 95th percentile effluent temperature of 22.7°C was calculated to represent *dry weather* conditions, and a 95th percentile effluent temperature of 19.5°C was calculated to represent *wet weather* conditions. These temperatures were used to represent maximum

temperature for *chronic* water quality criteria. Lastly, an effluent temperature of 17.8°C was calculated to represent annual average conditions.

Columbia River receiving water conditions used in the modeling were developed from field measurements at the proposed offshore diffuser site, and these were collected by CH2M during the August to October 2015 period under low river flow conditions. The receiving water characteristics applied in the modeling of the selected outfall diffuser configuration are summarized in Tables 4-9 through 4-12.

Other key model inputs include ambient temperature and water (discharge) depth. The current meter records and water column profiles collected in 2015 were also used to validate ambient river temperatures used for the modeling of dry weather conditions. Long-term records collected by the USGS at Vancouver, Washington (gage 14144700) for the 13-year period from August 1967 to October 1979 were used to develop a cumulative frequency distribution of river temperature.

Based on these data sources, a 90th-percentile ambient river temperature of 21.1°C was calculated to represent typical dry weather (May through October) conditions. Similarly, a 90th-percentile ambient river temperature of 10.7°C was calculated to represent typical wet weather (November through April) conditions. An annual average temperature of 12.4°C is based on the 13-year period of record (1967 to 1979) collected by the USGS for the Columbia River at Vancouver, Washington.

Water depths used in the modeling evaluation are based on information provided by the bathymetric survey conducted in July 2015, the FlowMaster program, and depth confirmations at the outfall site during the field data collections in the August–October period in 2015.

Modeling Results

The selected outfall diffuser configuration (144-foot-long, 10-port diffuser) was modeled using VP (the UM3 model) and the inputs listed in Tables 4-9 through 4-12. These modeling summary tables include the defined scenarios (based on water quality criteria, effluent flow scenario, and critical river flow scenario), effluent flow and temperatures, river flow and temperature, ambient current velocity, diffuser discharge depth, and model-predicted dilution factors at the AZB and MZB.

An additional column has been added to the right side of each of the summary tables for the chronic water quality criteria results. For chronic mixing zones located in salt water and tidally-influenced freshwater, Appendix C of the Permit Writer's Manual (Ecology, 2015) specifies that the critical receiving water current velocity is defined as the 50th-percentile current velocity derived from a cumulative frequency distribution analysis *over at least one tidal cycle*. Since site-specific current velocities (measured during the low river flow period) demonstrated that flood tides occur only about 24 percent of the time at the proposed discharge site, a time-weighted proportion (i.e., 24 percent flood tide/76 percent ebb tide) was applied to the dilution factors to represent tidally-averaged results at the chronic MZB.

The model-predicted dilution factors are summarized in Table 4-9 for the existing (2010 to 2016) effluent flows, Table 4-10 for projected 2025 effluent flows, Table 4-11 for projected 2040 effluent flows, and Table 4-12 for ultimate (buildout) effluent flows. The Permit Writer's Manual specifies that dilutions in a tidally influenced river will be flux-average dilutions at both the acute zone boundary (AZB) and at the chronic mixing zone boundary (MZB); these are presented in the modeling results summary tables. The UM3 model input and output are included in Appendix I.

The modeling results for the effluent flow scenarios with the selected outfall diffuser configuration described previously are summarized in the following sections.

Existing Effluent Flows

The results of the dilution modeling for existing (2010 to 2016) effluent flows are represented by Model Cases SCTP1 through SCTP11 in Table 4-9 for dry and wet season acute dilution conditions (Model Cases

SCTP1 to SCTP5), dry and wet season chronic dilution conditions (Model Cases SCTP6 to SCTP9), and for human health conditions (Model Cases SCTP10 and SCTP11).

The modeling results for acute aquatic life criteria conditions show predicted dilution factors at the AZB (24.3 feet upstream and downstream) from 29 to 42 under all seasonal effluent and receiving water conditions. The worst-case acute dilution factor of 29 is predicted to occur under dry season conditions, a 7Q10-low river flow (83,506 cfs), the lowest 10th percentile flood tide current velocity (4.2 cm/sec), and the highest daily maximum effluent flow (10.01 mgd).

The modeling results also show that the predicted dilution factor at the chronic mixing zone boundary (243 feet upstream and downstream) is 178 under critical dry season conditions of low river flows and velocities, and 188 under wet season conditions of high river stage and velocities. The lowest predicted dilution factor at the chronic mixing zone boundary is based on the tidally-averaged/time weighted dilution factor of 178 (represented by Model Cases SCTP6 and SCTP7). Model-predicted dilution factors under annual average conditions (30Q5 river flow and the harmonic mean flow) range from 188 to 195, as shown in Table 4-9.

Projected 2025 Effluent Flows

The results of the dilution modeling for projected 2025 effluent flows are represented by Model Cases SCTP12 through SCTP22 in Table 4-10 for dry and wet season acute dilution conditions (Model Cases SCTP12 to SCTP16), dry and wet season chronic dilution conditions (Model Cases SCTP17 to SCTP20), and for human health conditions (Model Cases SCTP21 and SCTP22).

The modeling results for acute aquatic life criteria conditions show predicted dilution factors at the AZB (24.3 feet upstream and downstream) from 21 to 37 under all seasonal effluent and receiving water conditions. The worst-case acute dilution factor of 21 is predicted to occur under dry season conditions, a 7Q10-low river flow (83,506 cfs), the lowest 10th percentile flood tide current velocity (4.2 cm/sec), and the highest daily maximum effluent flow (18.92 mgd).

The modeling results also show that the predicted dilution factor at the chronic MZB (243 feet upstream and downstream) is 139 under critical dry season conditions of low river flows and velocities, and 142 under wet season conditions of high river stage and velocities. The lowest predicted dilution factor at the chronic mixing zone boundary is based on the tidally-averaged/time weighted dilution factor of 139 (represented by Model Cases SCTP17 and SCTP18). Model-predicted dilution factors under annual average conditions (30Q5 river flow and the harmonic mean flow) range from 142 to 156, as shown in Table 4-10.

Projected 2040 Effluent Flows

The results of the dilution modeling for projected 2040 effluent flows are represented by Model Cases SCTP23 through SCTP33 in Table 4-11 for dry and wet season acute dilution conditions (Model Cases SCTP23 to SCTP27), dry and wet season chronic dilution conditions (Model Cases SCTP28 to SCTP31), and for human health conditions (Model Cases SCTP32 and SCTP33).

The modeling results for acute aquatic life criteria conditions show predicted dilution factors at the AZB (24.3 feet upstream and downstream) from 18 to 34 under all seasonal effluent and receiving water conditions. The worst-case acute dilution factor of 18 is predicted to occur under dry season conditions, a 7Q10-low river flow (83,506 cfs), the lowest 10th percentile flood tide current velocity (4.2 cm/sec), and the highest daily maximum effluent flow (25.93 mgd).

The modeling results also show that the predicted dilution factor at the chronic mixing zone boundary (243 feet upstream and downstream) is 122 under critical dry season conditions of low river flows and velocities, and 124 under wet season conditions of high river stage and velocities. The lowest predicted dilution factor at the chronic mixing zone boundary is based on the tidally-averaged/time-weighted dilution factor of 122 (represented by Model Cases SCTP28 and SCTP29). Model-predicted dilution

factors under annual average conditions (30Q5 river flow and the harmonic mean flow) range from 127 to 140, as shown in Table 4-11.

Projected Buildout Effluent Flows

The results of the dilution modeling for projected buildout (ultimate) effluent flows are represented by Model Cases SCTP34 through SCTP44 in Table 4-12 for dry and wet season acute dilution conditions (Model Cases SCTP34 to SCTP38), dry and wet season chronic dilution conditions (Model Cases SCTP39 to SCTP42), and for human health conditions (Model Cases SCTP43 and SCTP44).

The modeling results for acute aquatic life criteria conditions show predicted dilution factors at the AZB (24.3 feet upstream and downstream) from 16 to 31 under all seasonal effluent and receiving water conditions. The worst-case acute dilution factor of 16 is predicted to occur under dry season conditions, a 7Q10-low river flow (83,506 cfs), the lowest 10th percentile flood tide current velocity (4.2 cm/sec), and the highest daily maximum effluent flow (37.31 mgd).

The modeling results also show that the predicted dilution factor at the chronic mixing zone boundary (243 feet upstream and downstream) is 107 under critical dry season conditions of low river flows and velocities, and 109 under wet season conditions of high river stage and velocities. The lowest predicted dilution factor at the chronic mixing zone boundary is based on the tidally-averaged/time weighted dilution factor of 107 (represented by Model Cases SCTP39 and SCTP40). Model-predicted dilution factors under annual average conditions (30Q5 river flow and the harmonic mean flow) range from 126 to 127, as shown in Table 4-12.

Table 4-9. Model-Predicted Dilution Factors under Critical Dry Season, Wet Season, and Annual Average Discharge Conditions for the Salmon Creek Outfall Replacement—Existing (2010–2016) Effluent Flows
Engineering Report for the Phase 5A Project—Columbia River Outfall and Effluent Pipeline

Model Case No.	Columbia River Receiving Water Conditions						Effluent Conditions ^b			Outfall Diffuser Configuration				Model-Predicted Dilution Factors (DF) at Mixing Zone Boundaries ^d			
	Seasonal Basis ^a	River Discharge	River Flow (cfs)	Temperature (deg. C)	Tidal Condition	Current Speed (cm/sec)	Flow Rate (mgd)	Temperature Frequency	Temperature (deg. C)	No./Size Ports (in.) & Spacing (ft)	Headloss (feet)	Equivalent Port Diam. (in.) & Port Velocity (fps)	Diffuser Discharge Depth (feet) ^c	Acute Zone (24.3 feet) ^e	Mixing Zone (243 feet) ^f	Tidally-Averaged & Time Weighted (Chronic Only) ^g	
Acute Water Quality Criteria																	
SCTP1	dry	7Q10-low	83,506	21.1 (90th percentile)	ebb (downstream)	12.9 (10th percentile)	10.01 (highest daily maximum)	99th percentile (dry season)	23.0	10-16" TFDs at 16-ft	0.24	8.30 (4.12)	42.6	42	n/a	n/a	
SCTP2						37.6 (90th percentile)									38	n/a	n/a
SCTP3					flood (upstream)	4.2 (10th percentile)									29	n/a	n/a
SCTP4						25.1 (90th percentile)									41	n/a	n/a
SCTP5	wet	7Q10-high	108,766	10.7 (90th percentile)	ebb (downstream)	34.4 (50th percentile)	14.81 (highest daily max.)	99th percentile (wet season)	19.8	10-16" TFDs at 16-ft	0.36	9.10 (5.07)	43.2	38	n/a	n/a	
Chronic Water Quality Criteria																	
SCTP6	dry	7Q10-low	83,506	21.1 (90th percentile)	ebb (downstream)	31.1 (50th percentile)	8.07 (highest monthly avg.)	95th percentile (dry season)	22.7	10-16" TFDs at 16-ft	0.20	7.89 (3.68)	42.6	n/a	171	178	
SCTP7					flood (upstream)	15.5 (50th percentile)									n/a		201
SCTP8	wet	7Q10-high	108,766	10.7 (90th percentile)	ebb (downstream)	34.4 (50th percentile)	10.73 (maximum monthly)	95th percentile (wet season)	19.5	10-16" TFDs at 16-ft	0.26	8.44 (4.27)	43.2	n/a	186	188	
SCTP9					flood (upstream)	17.1 (50th percentile)									n/a		194
Human Health Criteria: Carcinogen																	
SCTP10	annual	harmonic mean	191,106	12.4 (50th percentile)	ebb (downstream)	59.4 (50th percentile)	7.41 (annual average)	50th percentile	17.8	10-16" TFDs at 16-ft	0.18	7.73 (3.52)	43.8	n/a	188	n/a	
Human Health Criteria: Non-Carcinogen																	
SCTP11	annual	30Q5	99,893	12.4 (50th percentile)	ebb (downstream)	32.0 (50th percentile)	8.07 (highest monthly avg.)	50th percentile	17.8	10-16" TFDs at 16-ft	0.20	7.89 (3.68)	42.7	n/a	195	n/a	

Notes:

^a Dry season is assumed to be the period from May 1 to October 31, wet season from November 1 to April 30.

^b Flow and temperature values are based on effluent measurements from January 2010 through April 2016. Peaking factors were developed for dry and wet weather conditions to provide flow projections.

^c Discharge depth represents the approximate average depth of the diffuser ports based on (relative to) 7Q10 low flow conditions.

^d Based on procedures in the Water Quality Program Permit Writer's Manual (Ecology, revised 2015), model-predicted dilution factors for discharges in 'marine and rotating direction' environments (i.e., estuaries) are flux-average values for both acute and chronic conditions.

^e The zone where the acute criteria may be exceeded (i.e., acute zone boundary) is a distance of 24.3 feet (7.4 meters) from any discharge port in both the upstream and the downstream direction.

^f The mixing zone boundary is 243 feet (74 meters) in both the upstream and the downstream direction.

^g For chronic mixing zones located in salt water and tidally-influenced freshwater, Appendix C of the Water Quality Program Permit Writer's Manual (Washington Department of Ecology, January 2015) specifies that the critical receiving water current velocity is defined as the 50th percentile current velocity derived from a cumulative frequency distribution analysis *over at least once tidal cycle*. Since site-specific current velocities (measured during the low river flow period) demonstrated that flood tides occur approximately 24 percent of the time at the proposed outfall site, this time-weighted proportion (i.e., 24% flood tide/76% ebb tide) was applied in order to represent tidally-averaged results at the chronic mixing zone boundary.

Table 4-10. Model-Predicted Dilution Factors under Critical Dry Season, Wet Season, and Annual Average Discharge Conditions for the Salmon Creek Outfall Replacement—Projected 2025 Effluent Flows
Engineering Report for the Phase 5A Project—Columbia River Outfall and Effluent Pipeline

Model Case No.	Columbia River Receiving Water Conditions						Effluent Conditions ^b			Outfall Diffuser Configuration				Model-Predicted Dilution Factors (DF) at Mixing Zone Boundaries ^d		
	Seasonal Basis ^a	River Discharge	River Flow (cfs)	Temperature (deg. C)	Tidal Condition	Current Speed (cm/sec)	Flow Rate (mgd)	Temperature		No./Size Ports (in.) & Spacing (ft)	Headloss (feet)	Equivalent Port Diam. (in.) & Port Velocity (fps)	Diffuser Discharge Depth (feet) ^c	Acute Zone (24.3 feet) ^e	Mixing Zone (243 feet) ^f	Tidally-Averaged & Time Weighted (Chronic Only) ^g
								Frequency	(deg. C)							
Acute Water Quality Criteria																
SCTP12	dry	7Q10-low	83,506	21.1 (90th percentile)	ebb	12.9 (10th percentile)	18.92 (highest daily maximum)	99th percentile (dry season)	23.0	10-16" TFDs at 16-ft	0.45	9.64 (5.78)	42.6	31	n/a	n/a
SCTP13					(downstream)	37.6 (90th percentile)								36	n/a	n/a
SCTP14					flood	4.2 (10th percentile)								21	n/a	n/a
SCTP15					(upstream)	25.1 (90th percentile)								37	n/a	n/a
SCTP16	wet	7Q10-high	108,766	10.7 (90th percentile)	ebb	34.4 (50th percentile)	25.82 (highest daily max.)	99th percentile (wet season)	19.8	10-16" TFDs at 16-ft	0.60	10.33 (6.87)	43.2	35	n/a	n/a
Chronic Water Quality Criteria																
SCTP17	dry	7Q10-low	83,506	21.1 (90th percentile)	ebb	31.1 (50th percentile)	14.82 (highest monthly avg.)	95th percentile (dry season)	22.7	10-16" TFDs at 16-ft	0.36	9.11 (5.07)	42.6	n/a	139	139
SCTP18					(downstream)	15.5 (50th percentile)								n/a	139	
SCTP19	wet	7Q10-high	108,766	10.7 (90th percentile)	ebb	34.4 (50th percentile)	19.36 (maximum monthly)	95th percentile (wet season)	19.5	10-16" TFDs at 16-ft	0.46	9.68 (5.86)	43.2	n/a	149	142
SCTP20					(downstream)	17.1 (50th percentile)								n/a	118	
Human Health Criteria: Carcinogen																
SCTP21	annual	harmonic mean	191,106	12.4 (50th percentile)	ebb	59.4 (50th percentile)	14.67 (annual average)	50th percentile	17.8	10-16" TFDs at 16-ft	0.35	9.09 (5.04)	43.8	n/a	142	n/a
Human Health Criteria: Non-Carcinogen																
SCTP22	annual	30Q5	99,893	12.4 (50th percentile)	ebb	32.0 (50th percentile)	14.82 (highest monthly avg.)	50th percentile	17.8	10-16" TFDs at 16-ft	0.36	9.11 (5.07)	42.7	n/a	156	n/a

Notes:

- ^a Dry season is assumed to be the period from May 1 to October 31, wet season from November 1 to April 30.
- ^b Flow and temperature values are based on effluent measurements from January 2010 through April 2016. Peaking factors were developed for dry and wet weather conditions to provide flow projections.
- ^c Discharge depth represents the approximate average depth of the diffuser ports based on (relative to) 7Q10 low flow conditions.
- ^d Based on procedures in the Water Quality Program Permit Writer's Manual (Ecology, revised 2015), model-predicted dilution factors for discharges in 'marine and rotating direction' environments (i.e., estuaries) are flux-average values for both acute and chronic conditions.
- ^e The zone where the acute criteria may be exceeded (i.e., acute zone boundary) is a distance of 24.3 feet (7.4 meters) from any discharge port in both the upstream and the downstream direction.
- ^f The mixing zone boundary is 243 feet (74 meters) in both the upstream and the downstream direction.
- ^g For chronic mixing zones located in salt water and tidally-influenced freshwater, Appendix C of the Water Quality Program Permit Writer's Manual (Washington Department of Ecology, January 2015) specifies that the critical receiving water current velocity is defined as the 50th percentile current velocity derived from a cumulative frequency distribution analysis *over at least once tidal cycle*. Since site-specific current velocities (measured during the low river flow period) demonstrated that flood tides occur approximately 24 percent of the time at the proposed outfall site, this time-weighted proportion (i.e., 24% flood tide/76% ebb tide) was applied in order to represent tidally-averaged results at the chronic mixing zone boundary.

Table 4-11. Model-Predicted Dilution Factors under Critical Dry Season, Wet Season, and Annual Average Discharge Conditions for the Salmon Creek Outfall Replacement—Projected 2040 Effluent Flows

Engineering Report for the Phase 5A Project—Columbia River Outfall and Effluent Pipeline

Model Case No.	Columbia River Receiving Water Conditions						Effluent Conditions ^b			Outfall Diffuser Configuration				Model-Predicted Dilution Factors (DF) at Mixing Zone Boundaries ^d		
	Seasonal Basis ^a	River Discharge	River Flow (cfs)	Temperature (deg. C)	Tidal Condition	Current Speed (cm/sec)	Flow Rate (mgd)	Temperature		No./Size Ports (in.) & Spacing (ft)	Headloss (feet)	Equivalent Port Diam. (in.) & Port Velocity (fps)	Diffuser Discharge Depth (feet) ^c	Acute Zone (24.3 feet) ^e	Mixing Zone (243 feet) ^f	Tidally-Averaged & Time Weighted (Chronic Only) ^g
								Frequency	(deg. C)							
Acute Water Quality Criteria																
SCTP23	dry	7Q10-low	83,506	21.1 (90th percentile)	ebb (downstream)	12.9 (10th percentile)	25.93 (highest daily maximum)	99th percentile (dry season)	23.0	10-16" TFDs at 16-ft	0.61	10.34 (6.88)	42.6	27	n/a	n/a
SCTP24						37.6 (90th percentile)								34	n/a	n/a
SCTP25					flood (upstream)	4.2 (10th percentile)								18	n/a	n/a
SCTP26						25.1 (90th percentile)								33	n/a	n/a
SCTP27	wet	7Q10-high	108,766	10.7 (90th percentile)	ebb (downstream)	34.4 (50th percentile)	35.38 (highest daily max.)	99th percentile (wet season)	19.8	10-16" TFDs at 16-ft	0.81	11.05 (8.22)	43.2	32	n/a	n/a
Chronic Water Quality Criteria																
SCTP28	dry	7Q10-low	83,506	21.1 (90th percentile)	ebb (downstream)	31.1 (50th percentile)	20.30 (highest monthly avg.)	95th percentile (dry season)	22.7	10-16" TFDs at 16-ft	0.48	9.79 (6.01)	42.6	n/a	127	122
SCTP29					flood (upstream)	15.5 (50th percentile)								n/a	107	
SCTP30	wet	7Q10-high	108,766	10.7 (90th percentile)	ebb (downstream)	34.4 (50th percentile)	26.53 (maximum monthly)	95th percentile (wet season)	19.5	10-16" TFDs at 16-ft	0.62	10.39 (6.97)	43.2	n/a	135	124
SCTP31					flood (upstream)	17.1 (50th percentile)								n/a	91	
Human Health Criteria: Carcinogen																
SCTP32	annual	harmonic mean	191,106	12.4 (50th percentile)	ebb (downstream)	59.4 (50th percentile)	20.10 (annual average)	50th percentile	17.8	10-16" TFDs at 16-ft	0.48	9.76 (5.98)	43.8	n/a	127	n/a
Human Health Criteria: Non-Carcinogen																
SCTP33	annual	30Q5	99,893	12.4 (50th percentile)	ebb (downstream)	32.0 (50th percentile)	20.30 (highest monthly)	50th percentile	17.8	10-16" TFDs at 16-ft	0.48	9.79 (6.01)	42.7	n/a	140	n/a

Notes:^a Dry season is assumed to be the period from May 1 to October 31, wet season from November 1 to April 30.^b Flow and temperature values are based on effluent measurements from January 2010 through April 2016. Peaking factors were developed for dry and wet weather conditions to provide flow projections.^c Discharge depth represents the approximate average depth of the diffuser ports based on (relative to) 7Q10 low flow conditions.^d Based on procedures in the Water Quality Program Permit Writer's Manual (Ecology, revised 2015), model-predicted dilution factors for discharges in 'marine and rotating direction' environments (i.e., estuaries) are flux-average values for both acute and chronic conditions.^e The zone where the acute criteria may be exceeded (i.e., acute zone boundary) is a distance of 24.3 feet (7.4 meters) from any discharge port in both the upstream and the downstream direction.^f The mixing zone boundary is 243 feet (74 meters) in both the upstream and the downstream direction.^g For chronic mixing zones located in salt water and tidally-influenced freshwater, Appendix C of the Water Quality Program Permit Writer's Manual (Washington Department of Ecology, January 2015) specifies that the critical receiving water current velocity is defined as the 50th percentile current velocity derived from a cumulative frequency distribution analysis *over at least once tidal cycle*. Since site-specific current velocities (measured during the low river flow period) demonstrated that flood tides occur approximately 24 percent of the time at the proposed outfall site, this time-weighted proportion (i.e., 24% flood tide/76% ebb tide) was applied in order to represent tidally-averaged results at the chronic mixing zone boundary.

Table 4-12. Model-Predicted Dilution Factors under Critical Dry Season, Wet Season, and Annual Average Discharge Conditions for the Salmon Creek Outfall Replacement—Projected Ultimate (Buildout) Effluent Flows
Engineering Report for the Phase 5A Project—Columbia River Outfall and Effluent Pipeline

Model Case No.	Columbia River Receiving Water Conditions						Effluent Conditions ^b			Outfall Diffuser Configuration				Model-Predicted Dilution Factors (DF) at Mixing Zone Boundaries ^d		
	Seasonal Basis ^a	River Discharge	River Flow (cfs)	Temperature (deg. C)	Tidal Condition	Current Speed (cm/sec)	Flow Rate (mgd)	Temperature Frequency	Temperature (deg. C)	No./Size Ports (in.) & Spacing (ft)	Headloss (feet)	Equivalent Port Diam. (in.) & Port Velocity (fps)	Diffuser Discharge Depth (feet) ^c	Acute Zone (24.3 feet) ^e	Mixing Zone (243 feet) ^f	Tidally-Averaged & Time Weighted (Chronic Only) ^g
Acute Water Quality Criteria																
SCTP34	dry	7Q10-low	83,506	21.1 (90th percentile)	ebb	12.9 (10th percentile)	37.31 (highest daily maximum)	99th percentile (dry season)	23.0	10-16" TFDs at 16-ft	0.61	11.17 (8.48)	42.6	23	n/a	n/a
SCTP35					ebb	37.6 (90th percentile)								31	n/a	n/a
SCTP36					flood	4.2 (10th percentile)								16	n/a	n/a
SCTP37					flood	25.1 (90th percentile)								28	n/a	n/a
SCTP38	wet	7Q10-high	108,766	10.7 (90th percentile)	ebb	34.4 (50th percentile)	50.90 (highest daily max.)	99th percentile (wet season)	19.8	10-16" TFDs at 16-ft	0.81	11.89 (10.22)	43.2	27	n/a	n/a
Chronic Water Quality Criteria																
SCTP39	dry	7Q10-low	83,506	21.1 (90th percentile)	ebb	31.1 (50th percentile)	29.21 (highest monthly avg.)	95th percentile (dry season)	22.7	10-16" TFDs at 16-ft	0.48	10.61 (7.36)	42.6	n/a	116	107
SCTP40					flood	15.5 (50th percentile)								n/a	81	
SCTP41	wet	7Q10-high	108,766	10.7 (90th percentile)	ebb	34.4 (50th percentile)	38.17 (maximum monthly)	95th percentile (wet season)	19.5	10-16" TFDs at 16-ft	0.62	11.23 (8.59)	43.2	n/a	121	109
SCTP42					flood	17.1 (50th percentile)								n/a	71	
Human Health Criteria: Carcinogen																
SCTP43	annual	harmonic mean	191,106	12.4 (50th percentile)	ebb	59.4 (50th percentile)	28.92 (annual average)	50th percentile	17.8	10-16" TFDs at 16-ft	0.48	10.59 (7.32)	43.8	n/a	127	n/a
Human Health Criteria: Non-Carcinogen																
SCTP44	annual	30Q5	99,893	12.4 (50th percentile)	ebb	32.0 (50th percentile)	29.21 (highest monthly)	50th percentile	17.8	10-16" TFDs at 16-ft	0.48	10.61 (7.36)	42.7	n/a	126	n/a

Notes:

- ^a Dry season is assumed to be the period from May 1 to October 31, wet season from November 1 to April 30.
- ^b Flow and temperature values are based on effluent measurements from January 2010 through April 2016. Peaking factors were developed for dry and wet weather conditions to provide flow projections.
- ^c Discharge depth represents the approximate average depth of the diffuser ports based on (relative to) 7Q10 low flow conditions.
- ^d Based on procedures in the Water Quality Program Permit Writer's Manual (Ecology, revised 2015), model-predicted dilution factors for discharges in 'marine and rotating direction' environments (i.e., estuaries) are flux-average values for both acute and chronic conditions.
- ^e The zone where the acute criteria may be exceeded (i.e., acute zone boundary) is a distance of 24.3 feet (7.4 meters) from any discharge port in both the upstream and the downstream direction.
- ^f The mixing zone boundary is 243 feet (74 meters) in both the upstream and the downstream direction.
- ^g For chronic mixing zones located in salt water and tidally-influenced freshwater, Appendix C of the Water Quality Program Permit Writer's Manual (Washington Department of Ecology, January 2015) specifies that the critical receiving water current velocity is defined as the 50th percentile current velocity derived from a cumulative frequency distribution analysis *over at least once tidal cycle*. Since site-specific current velocities (measured during the low river flow period) demonstrated that flood tides occur approximately 24 percent of the time at the proposed outfall site, this time-weighted proportion (i.e., 24% flood tide/76% ebb tide) was applied in order to represent tidally-averaged results at the chronic mixing zone boundary.

4.4.3 Water Quality Standards Compliance

This section presents evaluations for the SCTP discharge compliance with state water quality standards including numeric water quality chemical criteria defined in WAC 173-201A-240 and antidegradation standards defined in WAC 173-201A-310 and -320.

4.4.3.1 Compliance with Water Quality Chemical Criteria

Table 4-13 summarizes the water quality chemical criteria compliance results for the new SCTP outfall diffuser in the Columbia River based on the dilution modeling results presented in Section 4.4.2 and the evaluation of dilution requirements based on effluent and background river chemistry data presented in Section 3.3. These results demonstrate that the new SCTP outfall diffuser will provide dilutions substantially greater than those required for effluent compliance with water quality criteria. As previously discussed in Section 3.3, the chemical bis(2ethylhexyl)phthalate (plasticizer used in cosmetics and soft and hard plastics) is present in low concentrations, but it cannot be addressed solely by dilution and it will require continued monitoring, source control, and treatment technology assessment for all dischargers in Washington.

Table 4-13. Model-Predicted Minimum Dilutions for Critical Conditions

Engineering Report for the Phase 5A Project—Columbia River Outfall and Effluent Pipeline

Effluent Flow Conditions	Acute Criteria – Aquatic Life	Chronic Criteria – Aquatic Life	Human Health Criteria – Non-Carcinogen	Human Health Criteria – Carcinogen
Phase 4	29	178	195	188
2025 Projected	21	139	156	142
2040 Projected	18	122	140	127
Buildout	16	107	126	127
Minimum Dilutions Required for Chemical Criteria Compliance ^a	7 (Copper)	68 (Ammonia)	None	556 (Phthalates) ^b 125 (Arsenic)

^a Refer to Table 3-4 in Section 3.

^b Effluent concentrations of bis(2ethylhexyl)phthalate is low (16.8 µg/L), but 2016 human health criterion is very low and will require monitoring, source control, and treatment technology assessment for all dischargers in Washington.

4.4.3.2 Water Quality and Tier II Antidegradation Evaluation

This section provides an evaluation of the Phase 5A Project and new outfall diffuser effects on water quality in the Columbia River and Washington water quality standards (WAC 173-201A). The Phase 5A Project effluent flows will be discharged into the Columbia River through the new outfall and diffuser. This evaluation has been prepared to be consistent with WAC 173-201A, and to align with the Permit Writer’s Manual (Ecology, 2015) and Supplemental Guidance on Implementing the Tier II Antidegradation (Ecology, 2011b).

The elements of this evaluation include assessment of discharge compliance with state water quality standards antidegradation rules, and a summary of biological resources and uses of the Columbia River discharge site.

The Water Quality Standards for Surface Waters of the State of Washington (WAC 173-201A) include narrative and numerical receiving water quality standards, as well as antidegradation rules in WAC 173-201A-300 that are consistent with the federal CWA. These standards address many water quality parameters: dissolved oxygen, temperature, toxicity, turbidity, pH, coliform bacteria, dissolved gases,

aesthetic water conditions, radioisotope concentrations, and toxic substances. Effects on each of these water quality parameters have been evaluated in the sections below using projected Phase 5A Project buildout effluent flows, existing wastewater data, updated dilution factors for the new outfall diffuser, and background Columbia River receiving water data.

Ecology has designated the lower Columbia River for spawning and rearing (as well as migration) of aquatic life in WAC 173-201A-602, and this designation is protective of rearing and migration year-round as well as salmon and trout spawning and emergence during the non-summer period (defined as September 17 to June 13). This designation is relevant to the application of water quality numeric standards for dissolved oxygen, temperature, pH, and turbidity.

Ecology has listed the lower Columbia River as impaired for temperature and dissolved oxygen upstream (approximately 5 miles) and downstream (approximately 8 miles) of the outfall site, under the Ecology 303(d) list approved by EPA in July 2016. Both are Class 5 listings, meaning that a TMDL study is expected to be developed unless additional data collections disqualify the listing. Reaches of the lower Columbia River have been listed for temperature for decades, and EPA has taken the lead in developing temperature TMDLs for the Columbia and Snake Rivers. The SCTP discharge compliance with temperature and dissolved oxygen standards is addressed below. This reach of the Columbia River is also listed as impaired for bacteria, and no new bacteria data have been collected since the 1998 listing.

Water Quality Compliance Evaluation

This section provides evaluations of the Phase 5A Project discharge compliance with water quality standards for dissolved oxygen, temperature, turbidity, pH, coliform bacteria, dissolved gases, aesthetic water conditions, radioisotope concentrations, toxicity, and toxic substances. Table 4-14 summarizes the water quality standards compliance evaluation provided in the following subsections.

Table 4-14. Summary of Water Quality Compliance Evaluation

Engineering Report for the Phase 5A Project—Columbia River Outfall and Effluent Pipeline

Parameter	Water Quality Standards (WQS)	WQS Allowable Change or Maximum	Calculated Maximum or Change	Compliance with WQ Standards
Dissolved Oxygen	6.5 mg/L 1-day minimum (June 14 – Sept 16)	0.2 mg/L	0.05 to 0.07 mg/L*	Yes
	8.0 mg/L 1-day minimum (Sept. 17 – June 13)			
Temperature	20.0°C 1-day Biological Criteria	0.3°C	0.02°C*	Yes
	33.0°C 1-day maximum acute temperature	< 33.0°C	23.0°C	Yes
	23.0°C 1-day maximum temperature	23.0°C	21.1°C*	Yes
	22.0°C 7-day maximum temperature	22.0°C	21.1°C*	Yes
Turbidity	5 NTU maximum increase if background ≤ 50 NTU	10 – 95%	0.9%*	Yes
	10% increase maximum if background > 50 NTU	10%	0.9%*	Yes
Total Dissolved Gas	Maximum < 110% Saturation	10%	0.9%*	Yes
pH	River pH 6.5 to 8.5 units		7.7 – 8.4*	Yes
Bacteria	100 cfu/100 mL and 200 cfu/100 mL fecal coliform		< 100 cfu/100 mL fecal coliform	Yes
Toxic Substances	Ammonia	2.3 mg/L (acute); 0.3 mg/L (chronic)	1.31 mg/L; 0.23 mg/L*	Yes
	Copper	10.3 µg/L (acute); 7.0 µg/L (chronic)	5.9 µg/L; 1.6 µg/L*	Yes

*Calculated based on minimum chronic dilution at MZB under buildout flows (107).

Dissolved Oxygen

The applicable water quality standard for dissolved oxygen (WAC 173-201A-200(1)(d)) specifies a lowest 1-day minimum dissolved oxygen of 6.5 mg/L during the summer period when salmon rearing and migration may occur, and a lowest 1-day minimum dissolved oxygen of 8.0 mg/L during the period when salmon spawning, rearing, and migration may occur (September 17 to June 13). The aquatic life dissolved oxygen criteria also state that “when a water body’s dissolved oxygen (DO) is lower than the criteria in Table 200 (1)(d) (or within 0.2 mg/L of the criteria) and that condition is due to natural conditions, then human actions considered cumulatively may not cause the DO of that water body to decrease more than 0.2 mg/L.” Site-specific criteria for the lower Columbia River also specify that “dissolved oxygen shall exceed 90 percent saturation.”

The wastewater influence on the receiving waters can be identified as immediate dissolved oxygen demand that occurs during the dilution process in the river. Receiving water dissolved oxygen concentrations at the completion of wastewater dilution (at the MZB) were predicted using Ecology’s spreadsheet calculation “Dissolved oxygen concentration following initial dilution” assuming the lowest model-predicted dilution factor at the MZB under 7Q10 low river flow conditions (dilution factor = 107; see Table 4-12). This calculation assumes a conservative effluent dissolved oxygen concentration of 3 mg/L, and an immediate effluent dissolved oxygen demand of 2 mg/L.

Thus, using the mass balance calculation in Ecology’s spreadsheet and a conservative assumption that the ambient dissolved oxygen concentration is just above the criteria, the dissolved oxygen concentration in the Columbia River at the SCTP discharge MZB is:

$$DO_{ambient} + \left(\frac{DO_{effluent} - DOD_{effluent} - DO_{ambient}}{DF \text{ at the MZB}} \right) = DO_{mixed}$$

$$6.6 \frac{mg}{L} + \left(\frac{3 \frac{mg}{L} - 2 \frac{mg}{L} + 6.6 \frac{mg}{L}}{107} \right) = 6.55 \frac{mg}{L}$$

And

$$8.1 \frac{mg}{L} + \left(\frac{3 \frac{mg}{L} - 2 \frac{mg}{L} - 8.1 \frac{mg}{L}}{107} \right) = 8.03 \frac{mg}{L}$$

Where:

DF = dilution factor

DO = dissolved oxygen

DOD = dissolved oxygen demand

The calculated worst-case decrease in dissolved oxygen is the difference between the dissolved oxygen concentration of the effluent and ambient (DO_{mixed}) and the ambient dissolved oxygen ($DO_{ambient}$). According to WAC 173-201A-200(1)(d), a reduction in dissolved oxygen of less than 0.2 mg/L is allowed, even in waterbodies that do not meet the applicable dissolved oxygen criterion. Under these worst-case scenarios, the decrease in dissolved oxygen at the MZB is limited to 0.05 mg/L (during the summer salmon rearing and migration period) and 0.07 mg/L (during the September through June spawning, rearing and migration period). Therefore, the SCTP discharge would not cause or contribute to a violation of this criterion.

Temperature

The temperature standards (WAC 173-201A-200(1)(c)) include narrative and numeric criteria. The lower Columbia River has specific temperature criteria that are defined in WAC 173-201A-602, Table 602. The numeric criteria for the lower Columbia River are:

“Temperature shall not exceed a 1-day maximum (1-DMax) of 20.0°C due to human activities. When natural conditions exceed a 1-DMax of 20.0°C, no temperature increase will be allowed which will raise the receiving water temperature by greater than 0.3°C; nor shall such temperature increases, at any time, exceed 0.3°C due to any single source or 1.1°C due to all such activities combined.”

In addition, WAC 173-201A-200(1)(c) stipulates that the maximum incremental temperature increase allowed and resulting from an individual point source cannot exceed $28/T+7$ (in degrees C) at the MZB, where T is background temperature. This maximum incremental temperature is only relevant when background river temperatures are equal to or less than 16.3°C.

The temperature standards also have guidelines for preventing acute lethality and barriers to migration of salmonids in WAC 173-201A-200(1c)(vii), as follows:

“(vii) The department will incorporate the following guidelines on preventing acute lethality and barriers to migration of salmonids into determinations of compliance with the narrative requirements for use protection established in this chapter (e.g., WAC 173-201A-310(1), 173-201A-400(4), and 173-201A-410 (1)(c)). The following site-level considerations do not, however, override the temperature criteria established for waters in subsection (1)(c) of this section or WAC 173-201A-600 through 173-201A-602:

- (A) Moderately acclimated (16-20°C, or 60.8-68°F) adult and juvenile salmonids will generally be protected from acute lethality by discrete human actions maintaining the 7-DADMax temperature at or below 22°C (71.6°F) and the 1-day maximum (1-DMax) temperature at or below 23°C (73.4°F).
- (B) Lethality to developing fish embryos can be expected to occur at a 1-DMax temperature greater than 17.5°C (63.5°F).
- (C) To protect aquatic organisms, discharge plume temperatures must be maintained such that fish could not be entrained (based on plume time of travel) for more than two seconds at temperatures above 33°C (91.4°F) to avoid creating areas that will cause near instantaneous lethality.
- (D) Barriers to adult salmonid migration are assumed to exist any time the 1-DMax temperature is greater than 22°C (71.6°F) and the adjacent downstream water temperatures are 3°C (5.4°F) or cooler.”

The compliance temperatures at the MZB in the river for the new SCTP wastewater discharge at buildout effluent flow conditions are summarized below. Based on an assumed maximum SCTP effluent temperature of 23.0°C and minimum dilution factor of 107 at the MZB (and 16 at the AZB) each compliance temperature condition has been assessed and the estimated maximum allowable effluent temperature is identified for each [answers in brackets below].

- 1) Aquatic life temperature criteria (1-day maximum temperature at or below 23°C) – [Maximum effluent temperature prior to discharge = 23.0°C]
- 2) Site-specific temperature criteria (year-round) = 20.0°C (1-DMax) due to human activities – [Maximum mixed effluent temperature at regulatory mixing zone (RMZ) = 20.02°C]
- 3) Site-specific temperature criteria (year-round) when natural conditions > 1-DMax of 20.0°C, then no temperature increase greater than 0.3°C – [Maximum mixed effluent temperature at RMZ = 20.02°C; temperature change of 0.02°C]

- 4) Individual point source (year-round) cannot exceed $28/T+7$ at the MZB, where T is background temperature – [not relevant due to high dilutions]
- 5) Acute lethality protection (adult and juvenile salmon) = 7-DADMax temperature $\leq 22^{\circ}\text{C}$, and 1-DMax temperature $\leq 23^{\circ}\text{C}$ – [Maximum mixed effluent temperature at AZB = 20.2°C]
- 6) Acute lethality protection (fish embryo) = 1-DMax temperature $< 17.5^{\circ}\text{C}$ – [not applicable to Columbia River site]
- 7) Acute lethality protection (fish) = plume discharge temperature after 2 seconds $< 33.0^{\circ}\text{C}$ – [Maximum effluent temperature 23°C]
- 8) Migration protection (adult salmon) = 1-DMax temperature $< 22^{\circ}\text{C}$, and background river temperature $\geq 3^{\circ}\text{C}$ cooler – [Maximum mixed effluent temperature at RMZ = 20.02°C]

To support this screening-level temperature compliance assessment of the Phase 5A Project discharge at buildout effluent flow, the temperature calculations described below have been developed.

An energy (mass) balance equation was applied to calculate the excess temperature at the MZB (the difference between the mixed temperature of effluent and river water and the background river temperature or temperature criteria). The worst-case temperature screening evaluation assumed that the river water temperature equals the temperature criterion of 20.0°C , and applied the maximum measured effluent temperature of 23.0°C (based on effluent data for the period of May 2010 through April 2016).

Using a mass balance equation and applying the following inputs, the mixed temperature increase at the MZB was calculated:

$$(Q_0 \times T_{effluent}) + (Q_{entrain} \times T_{criterion}) = (Q_0 + Q_{entrain}) \times (T_{mixed})$$

Where $T_{criterion}$ is the temperature of the receiving stream (based on applicable temperature criterion, $T_{criterion} = 20.0^{\circ}\text{C}$), $T_{effluent}$ is the maximum daily effluent temperature ($T_{effluent} = 23.0^{\circ}\text{C}$), Q_0 represents the effluent dilution factor prior to dilution ($Q_0 = 1$), and $Q_{entrain}$ is the river dilution portion that mixes with the effluent, $Q_{entrain} = 107$.

Using the model-predicted worst-case dilution factor of 107 at the MZB for buildout effluent flow, $Q_0 = 1$ (by definition) and $Q_{entrain} = 106$, solving the equation for T_{mixed} yields:

$$\frac{(1 \times 23.0^{\circ}\text{C}) + (106 \times 20.0^{\circ}\text{C})}{107} = T_{mixed} = 20.02^{\circ}\text{C}$$

The average temperature increase is the difference between the temperature of combined wastewater and stream mixture at the MZB (T_{mixed}) and the applicable stream temperature criterion ($T_{criterion}$), or $(20.02^{\circ}\text{C}) - (20.0^{\circ}\text{C}) = 0.02^{\circ}\text{C}$. Therefore, the estimated worst-case excess temperature difference is 0.02°C , and it is therefore not a “measurable” temperature increase (defined as *greater* than 0.3°C).

Turbidity

The turbidity criterion allows a maximum turbidity change of 5 nephelometric turbidity units (NTU) at the MZB when background river turbidity is 50 NTU or less, and up to a 10 percent increase in stream turbidity when background river turbidity is greater than 50 NTU (WAC 173-201A-200(1)(e)). SCTP is not required to monitor effluent turbidity or receiving water turbidity, and there is no basis to estimate values.

Based on the model-predicted dilution factors at the MZB under buildout flows, the effluent discharged through the SCTP outfall diffuser will be diluted by a factor of 107 and the mixed effluent and river turbidity will not exceed the turbidity criterion.

Total Dissolved Gas

The numeric and narrative standards for total dissolved gas are set forth in WAC 173-201A-200(1)(f), which limits dissolved gases in freshwater to less than 110 percent of saturation. The SCTP discharge will not release dissolved gases such as hydrogen sulfide, carbon dioxide, or other gases that would cause or contribute to a violation of this criterion in the Columbia River. The treated wastewater discharged to the Columbia River will contain dissolved oxygen as the only significant dissolved gas, and will not exceed 110 percent saturation for dissolved gases. Therefore, the SCTP discharge would not cause or contribute to a violation of this criterion.

pH

The effluent pH limit in the NPDES permit is a daily maximum of 6.0 to 9.0 standard units. The applicable pH standard for the Columbia River (WAC 173-201A-200(1)(g)) is between 6.5 and 8.5. According to effluent data from January 2010 through June 2015, effluent pH has remained between 6.13 and 7.39. Based on Columbia River monitoring data, the river pH ranges between 7.8 and 8.4. Based on a calculation of the mixed pH at the MZB using Ecology's RPA calculation spreadsheet (March 2015 version), the worst-case mixed pH at the MZB would not be less than 7.7 or more than 8.4. Therefore, the SCTP discharge would not cause or contribute to a violation of this criterion.

Bacteria

The numeric and narrative bacterial standards are set forth in WAC 173-201A, Table 200(2)(b). The freshwater bacteria criterion for primary contact recreation applicable in the lower Columbia River specifies that "fecal coliform organism levels must not exceed a geometric mean value of 100 colonies/100 mL, with not more than 10 percent of all samples (or any single sample when less than ten sample points exist) obtained for calculating the geometric mean value exceeding 200 colonies/100 mL."

Because the SCTP uses ultraviolet light disinfection to treat the wastewater before discharge, the discharge would not cause or contribute to a violation of this criterion.

Radioisotopes

WAC 173-201A-250 prohibits radioisotope concentrations in excess of maximum permissible concentrations defined in federal statutes. The SCTP treatment unit processes and discharge will not contain any radioisotopes.

Toxic Substances

WAC 173-201A-240 prohibits discharge of toxic pollutants in amounts that may be harmful to beneficial uses. WAC 173-201A-240, Table 240(3), establishes numeric criteria for the protection of aquatic organisms in freshwater and marine water, and the EPA-approved numeric criteria for the protection of human health were established in November 2016. An evaluation of the dilution factors required for the SCTP effluent maximum discharge concentrations to comply with the aquatic life and human health-based water quality criteria is presented in Table 3-4 in Section 3.3.

The dilution factors required for SCTP effluent compliance with acute aquatic life criteria are 8 (based on copper) and 13 (based on cyanide method detection limits). The minimum model-predicted acute dilution factor is 16 under dry season conditions for buildout effluent flow. The dilution factors required for SCTP effluent compliance with chronic aquatic life criteria are 12 (based on copper) and 37 (based on ammonia in the dry season). The minimum model-predicted chronic dilution factor is 107 under dry season conditions for buildout effluent flow.

For human health-based criteria, a required dilution factor of 125 is calculated for arsenic; however, the receiving water data show that the current approved human health criterion for arsenic is lower than the measured background arsenic concentrations in the Columbia River by an order of magnitude, and is therefore not attainable. In addition, three other detected chemicals that require high dilution factors

were bis(2-ethylhexyl)phthalate and pesticides beta-BHC and heptachlor (based on single measured pesticides in 2012). The pesticides beta-BHC and heptachlor are legacy pesticides and are no longer sold, so these may be due to private residences improperly disposing of old pesticides into the sewage system, and ongoing monitoring will resolve these sources. Bis(2-ethylhexyl)phthalate is ubiquitous in municipal wastewater effluents, and state and federal restriction could be needed to reduce sources to sewage systems.

Acute and Chronic Toxicity

The most recent permit requires the SCTP to perform quarterly acute and bi-annually chronic WET testing. All of the required WET test results have been in compliance with the permit effluent limits for both acute and chronic toxicity since 2011 through 2015. Because the projected Phase 5A Project discharge is not expected to result in an increase in pollutant concentrations, it is not expected to cause or contribute to a violation of acute and chronic toxicity criteria.

Antidegradation Rule

Washington's antidegradation rule is defined in WAC 173-201A-300, and the rule specifies the following purpose of the antidegradation policy:

- “(a) Restore and maintain the highest possible quality of the surface waters of Washington;
- (b) Describe situations under which water quality may be lowered from its current condition;
- (c) Apply to human activities that are likely to have an impact on the water quality of a surface water;
- (d) Ensure that all human activities that are likely to contribute to a lowering of water quality, at a minimum, apply all known, available, and reasonable methods of prevention, control, and treatment (AKART); and
- (e) Apply three levels of protection for surface waters of the state, as generally described below:
 - (i) Tier I is used to ensure existing and designated uses are maintained and protected and applies to all waters and all sources of pollution.
 - (ii) Tier II is used to ensure that waters of a higher quality than the criteria assigned in this chapter are not degraded unless such lowering of water quality is necessary and in the overriding public interest. Tier II applies only to a specific list of polluting activities.
 - (iii) Tier III is used to prevent the degradation of waters formally listed in this chapter as "outstanding resource waters," and applies to all sources of pollution.”

Washington's antidegradation rule provides the three levels of protection (Tiers I, II, and III) listed above. Tier I protections include maintaining and protecting existing designated uses, improving water quality conditions to align with water quality standards and protect existing designated uses, and identifying where natural conditions (exclusive of human actions) do not allow water quality standards to be met. Washington's antidegradation rule also provides that waterbodies “may not be further degraded” except as authorized by the rule (refer to WAC 173-201A-310(1)).

Tier II antidegradation protections address “new or expanded actions ... that are expected to cause a measurable change in the quality of the water,” and such actions “may not be allowed unless the department determines that the lowering of water quality is necessary and in the overriding public interest” (refer to WAC 173-201A-320(1)). Ecology has specified in the rule that a Tier II review will only be conducted for new or expanded actions conducted in accordance with the processes associated with NPDES discharge permits, as well as other permitting.

Ecology has interpreted “degradation” as a “measurable change in water quality” away from conditions unaffected by the source area (after allowing for mixing consistent with WAC 173-201A-400(7)). In the context of this rule, a measurable change is defined by Ecology as a:

- (a) Temperature increase of 0.3°C or greater

- (b) Dissolved oxygen decrease of 0.2 mg/L or greater
- (c) Bacteria level increase of 2 colony forming units/100 mL or greater
- (d) pH change of 0.1 units or greater
- (e) Turbidity increase of 0.5 NTU or greater, or
- (f) Any detectable increase in the concentration of a toxic or radioactive substance

Ecology rules specifies that “to determine that a lowering of water quality is necessary and in the overriding public interest, an analysis must be conducted for new or expanded actions when the resulting action has the potential to cause a measurable change in the physical, chemical, or biological quality of a water body.” The preceding evaluation of water quality standards compliance for the SCTP Phase 5A Project wastewater discharge to the Columbia River provides specific results to demonstrate that the discharge will not cause a measurable change in the river water quality.

Biological Resources and Uses of the Columbia River

The Columbia River supports both anadromous and non-anadromous (resident) species of fish. At the SCTP outfall discharge site, the Columbia River is used by anadromous fish primarily for migration. Fourteen salmonids are federally listed as threatened or endangered within this watershed. Juvenile salmon occur in the river estuary all year, as different species, size classes, and life history types continually move downstream and enter tidal waters from upstream.

StreamNet (2016) shows the following fish uses in the Columbia River near the SCTP outfall site:

- Spring, summer, and fall Chinook – migration
- Coho – rearing and migration
- Summer and winter steelhead – migration
- Sockeye – migration
- Chum – migration
- Pink – migration
- Eulachon – migration
- Green sturgeon – rearing and migration
- Bull trout – migration

Lower Columbia River Chinook salmon and Lower Columbia River steelhead are federal threatened species under the Endangered Species Act (ESA), and critical habitat was designated for both species in 2000 (NMFS and NOAA, 2000). These species use the lower Columbia River for rearing and migration. Lower Columbia River coho salmon is a state endangered and federal threatened species, and critical habitat was designated in 2016. Columbia River chum salmon is a federal threatened species and critical habitat was designated for Columbia River chum salmon in 2000 (NMFS and NOAA, 2000). Other evolutionarily significant units of these species and sockeye salmon may pass through the action area.

NOAA NMFS listed river eulachon (also known as “smelt”) for protection under the ESA on May 17, 2010. Eulachon ascend the Columbia River to spawn in the lower mainstem and tributaries. The lower Columbia River is critical habitat for eulachon (NOAA, 2012). Critical habitat for green sturgeon occurs in the Columbia River estuary, downstream of the proposed outfall.

The SCTP discharge is rapidly diluted, without adverse effects on the listed salmonid species, eulachon, or their aquatic habitat. As reviewed in the preceding section, the SCTP discharge will not cause or contribute to violations of temperature or other instream water quality standards. These standards have been developed to protect sensitive cold-water aquatic organisms, including ESA-listed species, and there are no uniquely sensitive species using the lower Columbia River that would not be adequately protected by these standards.

4.5 SCTP Effluent Pump Station Alternatives

SCTP pump station alternatives were evaluated and are described in this section, including pump configurations, control schemes, and an overview of a possible scheme for phasing pumps during Phases 5 through 9 of the SCTP Expansion Program (CH2M, 2013). (Recall that the Phase 5A Project and the Phase 5B Project together comprise Phase 5 of the Expansion Program. The Phase 5B Project will not trigger pump station configuration changes.)

4.5.1 Configurations

Projected effluent PHFs described in Section 3.1 that account for the Battle Ground equalization basin being offline were used as a basis of design for maximum flow for pump configuration and selection. Pump station alternatives for more than four pumps were not evaluated due to space limitations of the existing pump station. The existing pump station has four effluent pumps, and the wet well has little room for expansion, although expansion could be possible with significant structural and site modifications. Pump sizing alternatives consist of two general configurations as follows:

- Four equally sized pumps
- Two large pumps, two small pumps

Replacing two pumps at a time allows the pump station to alternate between equally sized pumps and two large/two small pumps. Replacing two pumps at a time limits capital investment and construction impacts; however, pump equipment age is extended, requiring additional maintenance to ensure pumps are in proper working order throughout the required service duration.

4.5.2 Control Schemes

4.5.2.1 Existing Effluent Controls

The effluent pump station is controlled via wet well water level monitoring. When wet well WSEs are low, pumps are off and the gravity effluent pipeline valve is open. When wet well WSEs rise above a LEAD PUMP ON set point, the gravity effluent pipeline valve is closed via an electric actuator and the lead pump is turned on at minimum speed. As the wet well rises, the LEAD pump speeds up until it reaches a 100 percent speed. If the level in the wet well continues to rise to the LAG 1 PUMP ON set point, a second pump is turned on and the LEAD and LAG 1 pump run at a reduced speed. As the wet well rises, the LEAD and LAG 1 pump speed up until they reach 100 percent speed. If the level in the wet well continues to rise to the LAG 2 PUMP ON set point, the LAG 2 pump is turned on and the LEAD, LAG 1, and LAG 2 pumps run at a reduced speed. As the wet well rises, all three pumps speed up until they reach 100 percent speed. If the level in the wet well continues to rise, the LAG 3 pump is turned on at 100 percent speed. However, firm capacity for current PHF is achieved with the largest pump out of service.

4.5.2.2 Pump Control Alternatives

Gravity flow versus river stage and required timing of pumping is described in the design criteria Section 4.1.4. Table 4-15 summarizes flows for Expansion Program Phases 4 through 9 using flow projections described in Section 3.1 and applying phasing as set out in the 2004 Facilities Plan (CH2M, 2004b). Minimum effluent flow rates are based on historical 2016 plant flow data in 15 minute intervals. Minimum observed flows were 21 percent of average annual flow rates. Flow control is as follows:

- Gravity Flows: Minimum flow rates must either be conveyed by gravity or pumped. During all scenarios except for when river approaches the 100-year flood stage minimum flow can be conveyed by gravity.

- **Pumped Flows:** At high river stage levels, pumping is required. To ensure there is trouble free transition between gravity and pumped effluent flows and to maximize gravity flow during high river stage conditions, the pump station control could raise the LEAD PUMP ON control elevations. Limited headroom is available in the effluent wet well, so elevations may only be raised approximately 12 inches. This change in pump control set points increases the maximum gravity flow from 3 mgd during a 100-year flood event to approximately 8.5 mgd.

Table 4-15. Flow Projections*Forecasted flow (mgd) without battleground equalization basin**Engineering Report for the Phase 5A Project—Columbia River Outfall and Effluent Piping*

Design phase	Year	Minimum Flow (mgd) ^a	AAF (mgd)	PHF (mgd)
Phase 4	2016	1.6	7.5	22
Phase 5 ^b	2022	2.1	10	29
Phase 6	2030	3.4	16	37
Phase 7	2036	4.3	20.7	44
Phase 8	2048	5	23.7	55
Phase 9	2066	6.5	31	72

^a Minimum flows based on historical 2016 plant flow data in 15 minute intervals. They are equal to 21% of AAF.^b Includes the Phase 5A Project.

AAF = Average Annual Flow

PHF = Peak Hour Flow

4.5.3 Pump Phasing Alternatives

SCTP Expansion Program pump phasing is described in detail in Appendix J. Table 4-16 shows the proposed pump station phasing improvements and equipment sizing for SCTP Expansion Program Phase 5 and possible pump phasing alternatives for future Phases 6 through 9. Note that the Phase 5A Project will provide capacity through Expansion Program Phase 6.

Table 4-16. Pump Station Phasing for the SCTP Expansion Program*Proposed pump station phasing and equipment sizing**Engineering Report for the Phase 5A Project—Columbia River Outfall and Effluent Pipeline*

Facilities Plan Phase	Phase 5*	Phase 6	Phase 7	Phase 8	Phase 9
Facilities plan phase years	2020–2029	2029–2035	2035–2047	2047–2057	2057–2066
Design phasing years	2020–2035		2035–2045	2045–2056	2056–2066
Pump station firm capacity (gpm)	30,400		35,900	44,650	50,700
[mgd]	[43.8]		[51.7]	[64.3]	[73]
Small pumps (two)					
Make	Fairbanks Nijhuis		Fairbanks Nijhuis	Fairbanks Nijhuis	
Model	24-inch - 8312-30-inch		30-inch - 8312-30-inch	30-inch - 8312-30-inch	
Flow/pump (gpm)	10,145		8,700	14,880	15,630
[mgd]	[14.6]		[12.5]	[21.4]	[22.5]

Table 4-16. Pump Station Phasing for the SCTP Expansion Program*Proposed pump station phasing and equipment sizing**Engineering Report for the Phase 5A Project—Columbia River Outfall and Effluent Pipeline*

Facilities Plan Phase	Phase 5*	Phase 6	Phase 7	Phase 8	Phase 9
Total dynamic head (feet)	20.7		27.0	42	52.6
Motor speed (rpm)	600		600	600	600
Motor horsepower	75		75	200	250
Bowl size (inches)	24		24	30	30
Pump column & discharge size (inches)	30		30	30	30
Discharge pipe and valv size (inches)	30		30	30	30
Large pumps (two)					
Make Model	Fairbanks Nijhuis 24-inch - 8312-30-inch		Fairbanks Nijhuis 30-inch- 8312-30-inch		Fairbanks Nijhuis 30-inch - 8312-36-inch
Flow/pump (gpm) [mgd]	10,145 [14.6]		18,500 [26.7]	14,880 [21.4]	19,380 [28]
Total dynamic head (feet)	20.7		30.0	42	54
Motor speed (rpm)	600		600	600	600
Motor horsepower	75		200	200	300
Bowl size (inches)	24		30	30	30
Pump column & discharge size (inches)	30		30	30	36
Discharge pipe and valve size (inches)	30		30	30	36

* Includes the Phase 5A Project.

gpm = gallons per minute

rpm = revolutions per minute

Figure 4-10 shows the effluent pump capacity by phase and year.

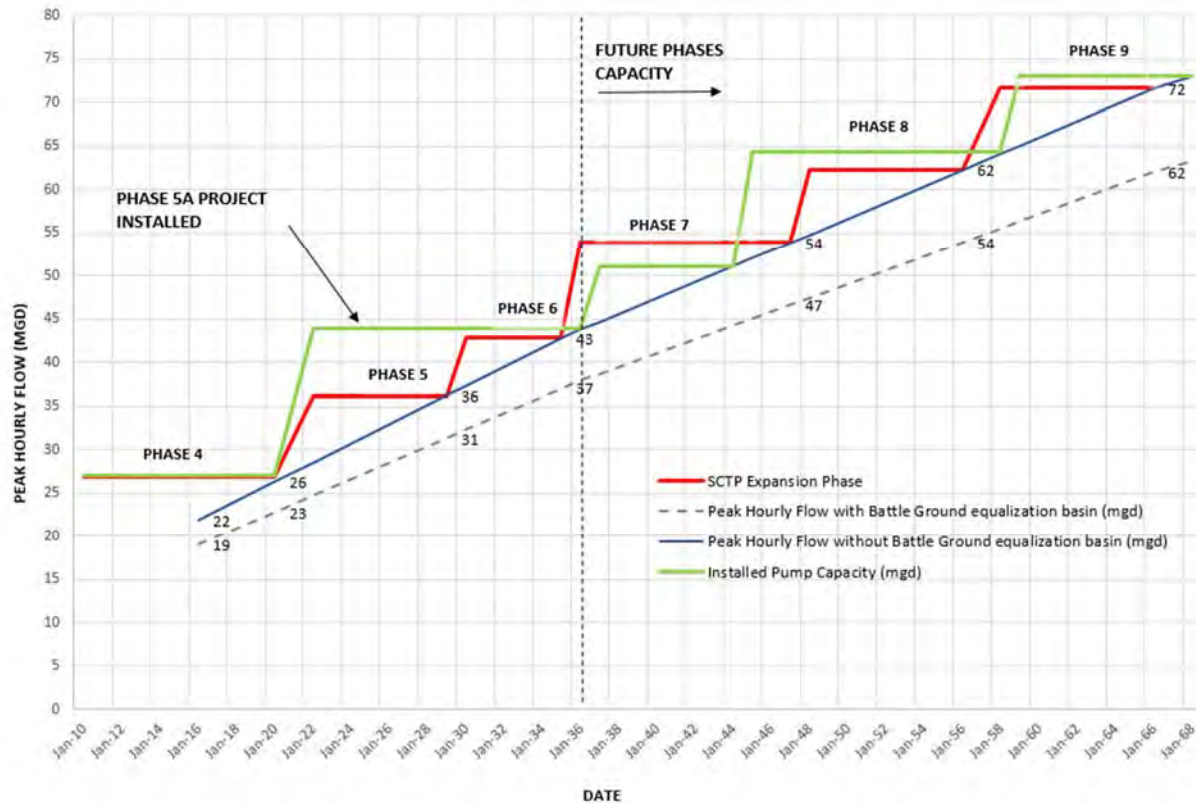


Figure 4-10. Effluent Pump Capacity by Phase and Year
 Engineering Report for the Phase 5A Project—Columbia River Outfall and Effluent Pipeline

4.6 Future Plans for Existing Effluent Pipeline and Diffuser

The existing outfall and diffuser will no longer be used to convey and diffuse treated effluent from SCTP into the Columbia River. For this reason, at a minimum, the diffuser could be removed. The following four alternatives were considered for the disposition of the existing effluent pipeline and outfall pipe. All alternatives assume removal of the diffuser:

- **Alternative 1:** Keep the outfall pipe, supporting piles, riprap, and effluent pipeline in place.
- **Alternative 2:** Remove the outfall pipe with the diffuser and supporting piles under the diffuser section; leave the riprap, remaining piles, and effluent pipeline in place.
- **Alternative 3:** Remove the outfall pipe with the diffuser and supporting piles under the diffuser section; also remove the supporting piles, riprap, and effluent pipeline section that could potentially be affected by the Columbia River shoreline erosion; keep the remaining piles and effluent pipeline in place.
- **Alternative 4:** Remove the entire system: outfall pipe, supporting piles, riprap, and effluent pipeline back to SCTP.

As discussed in the Section 4.1, Design Criteria, several criteria were considered to inform the decision of removing or maintaining the outfall and effluent pipeline. They include the following:

- Operational redundancy considerations
- Condition of the existing effluent pipeline and consideration of potential future uses
- Removal cost of outfall diffuser

- Risk and liability around potential exposure of the pipe in the Columbia River where shoreline erosion is a concern
- DNR easement requirements

The existing 30-inch-diameter effluent pipe between SCTP and the outfall is in good condition and could still serve for many years as a conveyance line. The Alliance sees a benefit in leaving it in place and using it as a back-up pipeline if maintenance is required on the new effluent pipeline. In the future, it could also serve as a local effluent reuse supply should reuse gain traction with local stakeholders.

An evaluation of shoreline erosion along the Columbia River (described in Appendix D) confirms the risk of continued future erosion at a rate of 3 to 5 feet per year. This would cause further exposure of the existing effluent pipeline along the shoreline beyond the section currently protected by riprap. If exposed, the pipeline between the Columbia River and the existing manhole could require further protection and maintenance even though it would not be used. This represents a liability and a cost for the Alliance. The cost and permitting efficiency of removing the 870-foot section of pipe during the construction of the new outfall becomes more obvious. Furthermore, based on discussions with DNR, future removal of this section of pipe would be required in 2035 when the easement lease with DNR comes up for renewal. DNR also could not confirm during a meeting in October 2017 that removal would not be required sooner than 2035 because the use of the easement would be altered once the outfall is no longer used for effluent discharge.

Removal of the riprap, placed in 2004 to protect the pipe, would also be required if the existing 30-inch-diameter pipe is removed. As explained in Appendix D, the riprap reduces erosion of the shoreline downstream of the outfall; however, at low flows, the riprap also contributes to the shoreline erosion process upstream of the outfall potentially increasing the risk of exposure of the future effluent pipe.

Based on the information presented above, Alternatives 1, 2, and 4 will not be evaluated further. The recommended Alternative 3 is summarized in Section 5.

4.7 Conclusion

Several effluent pipeline alignments, outfall configurations, and pump station upgrade alternatives were developed and evaluated for the project. They are within the range of effluent pipeline and outfall alternatives that were proposed and evaluated in the *Salmon Creek Wastewater Treatment Plant Expansion Program Final Environmental Impact Statement* (CH2M, 1995). The recommended alternative, summarized in Section 5, is developed from the available alignments and feasible construction techniques for each reach of the project, taking into account landowner and easement restrictions, environmental impacts, archaeological and wetland resources, practicable and permissible construction methods, utility conflicts, site access, anticipated shoreline erosion and river scour, geotechnical conditions, cost implications, and implementation risk. The evaluation was conducted to meet the project purpose and need, described in Section 1, as practicable, as follows:

- The selected effluent pipeline alignment, outfall diffuser configuration, and construction methods will minimize the construction footprint and adverse natural resources effects. It will also increase pipe reliability, minimize future maintenance activities and risks of damage or exposure of the pipeline, especially at waterway crossings and in the Columbia River. Maintenance at the discharge location will be reduced by extending the height of diffuser ports above prevalent sand wave heights and by laying the approach pipeline deeper and below the erodible shoreline.
- The pipeline diameter and material selection provides long-term capacity to support planned growth within the service area. The new effluent pipeline will allow for future increased effluent flow capacity for sewer customers served by the Alliance.

- The new Columbia River discharge facility (outfall diffuser) will ensure adequate mixing and dilution of treated wastewater discharged into the Columbia River and the diffuser improvements will achieve water quality standards over the foreseeable future. It will meet the effluent limitations and other wastewater discharge permit terms and conditions necessary to protect public health and the environment and will comply with Washington water quality standards (WAC 173-201A-200 to -260) and with the state’s antidegradation policy (WAC 173-201A-300 to -410).
- The cost of the recommended alternative ensures that the Alliance can continue to provide reliable wastewater treatment service at an affordable rate.
- The design of the effluent pipe at the Columbia River shoreline will account for riverbed and shoreline stability and erosion-caused exposure through removal of the existing outfall diffuser and placement of the pipeline below the general scour prism.
- The new pipeline, and concomitant pump station improvements, will allow the Ridgefield Treatment Plant and its outfall into Lake River to be decommissioned in the future, after additional collection system projects are in place, by providing sufficient capacity to convey Ridgefield flows.

The Alliance’s Phase 5A Project—Columbia River Outfall and Effluent Pipeline ensures that the agency can meet the region’s long-term wastewater treatment needs and continue safeguarding public health, environmental quality, and the service area’s economic future. The transmission system upgrade from the SCTP will support planned growth in the community. By ensuring adequate mixing and dilution of discharged treated effluent, the project will improve water quality in the Columbia River. And by planning and constructing an effluent pipeline that will satisfy future phased flow increases—as part of the Phase 5 expansion—the Alliance will make efficient use of limited funds and avoid repeated environmental impacts.

Recommended Alternative

5.1 Effluent Pipeline and Outfall Alignment

5.1.1 Recommended Alternative for the Effluent Pipeline

The Alliance developed and evaluated alternatives for a new effluent pipeline and outfall as described in Section 4. The recommended alternative was refined from available alignments and feasible construction techniques for each reach of the project, taking into account landowner and easement restrictions, environmental impacts, archaeological and wetland resources, practicable and permissible construction methods, utility conflicts, site access, anticipated shoreline erosion and river scour, geotechnical conditions, cost implications, and implementation risk. A summary of the recommended alternative pipe material, diameter and alignment for the effluent pipeline is provided below. Construction methods for each alignment reach are described in greater detail in Section 5.4. The 30 percent design drawings for the recommended alternative are provided at the end of this section.

The proposed effluent pipe extends approximately 6,100 feet from the effluent pump station at the western end of the SCTP to the planned outfall pipe extending into the Columbia River. The installation of the new line will include construction in open fields and crossing under BNSF railroad, Salmon Creek, Lake River, and NW Lower River Road.

Effluent Pipeline Diameter and Material. The new effluent discharge piping will consist of a single 48-inch-diameter pipe. Based on the cost comparison and history of use, steel pipe and HDPE pipe were selected as the preferred materials. Pipe materials are further discussed in Section 5.2.

Alignment Reach 1: SCTP to Salmon Creek. Reach 1 of the effluent pipe alignment begins at the connection to the SCTP, crosses the BNSF railroad, and continues across Salmon Creek onto Curtis Lake Ranch property (See PP-07 between Station 81+94 to 68+50 in the 30 percent design drawings).

The connection of the new effluent pipeline to the SCTP (PS-01) will be downstream of the pump station and will need to maintain the functionality of the existing 30-inch-diameter effluent line for continued operations during and after construction. Given the limited amount of storage at the plant, shutdown duration will need to be very short (no more than a 2 to 8 hours). Temporary line stops or plugs will be required with a temporary bypass pipe to allow for construction of the connection between the new and existing effluent pipelines. The new pipe and fittings will include two 48-inch-diameter butterfly valves to direct the flow into either the new 48-inch-diameter pipe or the existing 30-inch-diameter pipe. Access ports will be provided into the new pipe on both sides of each valve. Where necessary, thrust restraint at the connection between the existing pipe and the new pipe will be provided with thrust ties.

The recommended effluent pipeline installation at the BNSF railroad crossing consists of a trenchless construction using an auger boring method across the 513-foot railroad embankment with a 60-inch diameter steel casing as described in Section 4.3.2.2. Given the proximity of the railroad to Salmon Creek, the relatively steep terrain, and limited-access area on the west side of the railroad embankment, it is recommended to install the casing under the railroad in a downward direction from the east (SCTP) side, but this will be dictated by the contractor's means and methods.

An open cut trench method is recommended for the crossing of Salmon Creek. The open cut would be accomplished using a cofferdam to complete construction within half of the creek at a time, leaving the other half open for navigation by the public. Permits would be required to excavate within Salmon Creek. This alternative may require the use of a temporary trestle to access Salmon Creek to install the cofferdam, excavate the soils, place the pipe, and backfill the pipe.

Alignment Reach 2: Salmon Creek to Lake River. Reach 2 of the effluent pipe alignment begins on west side of Salmon Creek and continues to the eastern side of Lake River (Station 68+50 to 46+50 in the 30 percent design drawings).

This reach of the effluent pipeline covers approximately 2,200 linear feet. The recommended construction method for this reach is open cut with direct burial, as described in Section 4.3.3.

While the actual installation of the pipeline does not utilize a specialty construction technique, this reach has limited accessibility. As described in Section 4, there are multiple ways to access the work areas. Selection of one or more options for accessing the work area will depend on contractor means and methods and possible permitting issues or other constraints, to be determined during design development.

Alignment Reach 3: Lake River Crossing. Reach 3 of the effluent pipe alignment begins on the eastern side of Lake River and continues across Lake River (Station 46+50 to 42+00 in the 30 percent design drawings). As described in Section 4.3.4, a two-part open cut is recommended as the most feasible, cost-effective, and permittable construction method for the Lake River crossing. Trenchless alternatives included both HDD and direct pipe, but they were eliminated for cost reasons. Similar to the proposed Salmon Creek crossing method, half of the river would be open for navigation during construction. This approach would consist of a two-phase construction utilizing cofferdams, significant dewatering, and sediment controls. Sheet pile driving would likely be used for cofferdams. The pipeline would be constructed during the recommended in-water work period for Lake River (June 1 through October 31st), unless extended by WDFW.

Alignment Reach 4: Lake River to the Columbia River onshore angle point. Reach 4 of the effluent pipe alignment begins on the western side of Lake River (Station 42+00) and continues past the junction with the existing outfall pipe (Station 21+00) to the Columbia River onshore angle point (Station 13+00) (Station 42+00 to 13+00 in the 30 percent design drawings).

The recommended construction method for this reach is open cut with direct burial as described in Section 4.3.5.

A junction structure will be constructed to transition from the new effluent pipe to the new outfall. This will provide the opportunity to tie the existing 30-inch-diameter effluent pipeline into the new outfall. In this manner, the existing 30-inch-diameter effluent line can provide operational flexibility by allowing bypass flow through the existing line in the event an inspection of the new pipeline is required at a future date. The new junction structure will be constructed just east of the crossing of NW Lower River Road to avoid the erosion hazard along the Columbia River shoreline. The existing outfall will be abandoned after the new outfall is operational (refer to Section 5.1.3). In addition, this junction structure will allow the new effluent pipeline and outfall diffuser to be constructed on different schedules if this proves advantageous to managing contracts or costs.

After the junction with the existing 30-inch-diameter pipe, the new effluent pipeline will connect to the outfall and diffuser section. The effluent pipe jogs away from the existing alignment with two 45-degree bends to a distance of approximately 200-feet from the existing outfall pipe. The pipeline will be buried 10 to 35 feet deep and an articulated concrete revetment mat will be placed over the outfall pipe from Station 18+25 to 18+75 where the shoreline is prone to erosion. If future erosion of the bank reaches the mat, the exposed mat will serve as an indicator that the pipe could be exposed if the erosion continues. If the mat is exposed, it will minimize further erosion of the bank and provide time for subsequent maintenance action. Depth of pipe burial and revetment mat details are provided in the 30 percent design drawings (PP-01 and D-04).

Alignment Reach 5: Onshore Angle Point to Outfall Diffuser Terminus in the Columbia River. Reach 5 of the effluent pipe alignment begins offshore of the junction with the existing outfall pipe at the outfall pipe angle point (Station 13+00) and extends to the outfall diffuser terminus (Station 9+70). Refer to the

30 percent design drawings. The recommended construction method is open cut, underwater construction.

The effluent pipe at Station 13+00 angles downward with a mitered elbow and ball joint and extends downslope from -13 feet to -60 feet NAVD 1988 at a burial depth of 8 to 10 feet over the pipe crown. The effluent pipe at Station 11+30 angles horizontally with a mitered elbow and ball joint at -61 feet NAVD 1988 at pipe invert. The 160-foot-long outfall diffuser pipe section is a horizontal pipe (Station 11+30 to Station 9+70) with a burial depth of 6 to 8 feet over the pipe crown. The outfall pipe will terminate with a steel blind flange. The horizontal outfall diffuser pipe (Station 11+30 to Station 9+70) will be pile-supported along its length with 11 pile supports at 15-foot spacing along the 160-foot diffuser pipe. The distance between the first diffuser riser port and the last one atop the access manhole is 144 feet. The plan and profile of Pipe Reach 6 and the diffuser pipe section are provided in the 30% design drawings (PP-01 and D-06). Drawings of the diffuser pile supports are provided in the 30 percent design drawings (D-06 and D-01).

A steel pile navigation marker will be installed 40 feet offshore (due west) of the diffuser pipe terminus. Three 18-inch steel piles in a triangle with 5-foot spacing will be driven to -55 feet below the riverbed surface. The steel piles will extend 15 feet to 20 feet above OHWE and they will be connected together at two points located above and below OHWE with welded steel braces. The navigation marker will include an access ladder and a steel grate platform on the top with a USCG-approved solar-powered light. The marker will also have signage affixed on three sides to indicate that an exposed structure is located inshore of the marker. Details of the navigation marker are provided in the 30 percent design drawings (Drawing D-08).

5.1.2 Recommended Alternative for the Outfall Diffuser

The buried 160-foot-long outfall diffuser pipe section is a horizontal pipe with a burial depth of 6 to 8 feet over the pipe crown (Station 11+30 to Station 9+70). The 48-inch-diameter outfall pipe will terminate with a steel blind flange. The plan and profile of the diffuser pipe section are provided in the 30 percent design Drawing PP-01. The horizontal outfall diffuser pipe will be pile-supported along its length with 11 pile supports at 15-foot spacing along the 160-foot diffuser pipe (refer to 30 percent design Drawing D-06). Paired 12-inch steel piles will connect into a precast concrete pile cap with a saddle for the 48-inch-diameter pipe and two stainless steel pipe straps will bolt to the concrete pile cap (refer to 30 percent design Drawing D-01).

The recommended outfall diffuser will consist of 10 concrete-coated steel riser pipes that extend from a flange 2-feet above the diffuser pipe crown to a flange situated above the river bed. Riser pipes may include intermediate flanges to avoid riser pipe lengths of greater than 8 feet. The first 9 riser pipes from shore will consist of 16-inch ID pipe sections that are concrete coated. The last offshore riser will consist of a 36-inch access manhole with a 2-foot length of 16-inch riser flanged to the top. All 10 risers will be fitted with mitered 16-inch ID steel pipe elbows that terminate with a flange and 16-inch elastomeric check valve port (manufacturer to be defined in specifications). The distance between the first diffuser riser port and the last one atop the access manhole is 144 feet. Drawings of the diffuser pipe section and diffuser details are provided in the 30 percent design drawings (D-06 and D-07). The horizontal and vertical angles of the riser elbows and attached elastomeric check valve ports 45° downriver (north) and 20° above horizontal, respectively. The outfall diffuser will have all ports located at water depth of 42.6 feet (NGVD29) at low river flow conditions.

5.1.3 Removal of the Existing Outfall and Effluent Pipeline

Much of the 7,462-foot-long existing 30-inch-diameter effluent pipeline will remain in place. It is anticipated that the existing effluent pipeline from the SCTP to the last manhole between Lower River Road and the Columbia River will serve as a back-up pipeline and will be used if maintenance is required

on the new effluent pipeline. A future use for the pipeline could also include serving as effluent reuse. A connection will be installed to tie in the existing and new outfall pipes between Lower River Road and the Columbia River. A butterfly valve installed on each pipeline ahead of this junction and at the SCTP connection will allow for use and inspection of one or the other pipelines if necessary. The connections between the existing 30-inch-diameter and the new 48-inch-diameter is depicted in Drawings D-02, PP-02, and PP-08 provided at the end of this section.

The existing diffuser and outfall pipe will no longer be used to dilute flows to the river. Approximately 870 feet of pipe will be removed from the end of the diffuser back to the tie-in with the existing pipeline (Refer to Drawings PP-01 and PP-02). A discussion with DNR (Smith, 2017, personal communication), confirmed that DNR would prefer to remove the effluent pipeline and diffuser. Given the recent Alliance lease renewal (2017) and structure of the lease, which includes three stream crossings, DNR was open to discussion about a later removal of the outfall pipe in the Columbia River. However, an in-depth evaluation of shoreline erosion, provided in Appendix D, confirmed that the existing and future outfall pipe are at risk of exposure from continued shoreline erosion. Given the shoreline erosion risk to further expose the existing outfall pipe and the need for additional maintenance of an outfall pipe no longer in use, the 870-foot section of outfall pipe will be removed. Several elements associated with the existing outfall pipe will also be removed during construction as follows:

- **Supporting Piles.** There are 12 supporting piles under the existing diffuser and 14 supporting piles under the existing effluent pipeline along the Columbia River shoreline. It is anticipated that the 26 piles will be completely removed or cut below the mudline.
- **Riprap.** A 200-foot length of the outfall pipeline extending from outfall Station 66+20 to 68+20 was protected by a minimum depth of 40 feet of riprap in early 2004. It also included covering 30 feet of outfall pipe inshore that was unsupported by piles. The riprap will also be removed during construction of the new outfall.
- **Navigation Marker.** The existing three-pile dolphin, serving as a navigation marker, will no longer be needed after removal of the existing diffuser and effluent pipe. A new navigation marker will replace the existing one at a location closer to the new diffuser.

5.2 Pipe Materials and Project Elements

Both steel and high-density polyethylene (HDPE) are considered as acceptable pipe materials with certain limitations within specific portions of the alignment. HDPE pipe and steel pipe with appropriate linings and coatings are both corrosion resistant materials.

The connection to the SCTP includes elbows, wyes, tees, access manways, and flanged valves. Due to the number of fittings, steel pipe is recommended for the connection. The connection piping and valves allow flow to be directed to either the existing effluent pipe or the new effluent pipe. The new effluent pipe will continue west across open land owned by the Alliance. Pipe material in this section will be steel for connections at the plant, and the section between the plant and the BNSF railroad crossing could be steel or HDPE, although steel is recommended to avoid a transition ahead of the BNSF railroad crossing. One air valve vault will be located in this section. The air valve will be connected, using a small diameter air vent pipe, to the effluent line where air may become trapped as the downward grade of the pipe increases (on the west side of the BNSF railroad near Salmon Creek).

The crossing of the BNSF railroad tracks and embankment will be through a steel casing pipe. The carrier pipe will also be steel because of BNSF preferences and long-term success history for steel carrier pipes. Also HDPE fusion of a 48-inch-diameter pipe and feeding of the pipe through the steel casing will be challenging in the tight and steep construction area near the plant. At the west end of the casing, the grade of the effluent pipe will increase to cross under Salmon Creek. The Salmon Creek crossing will be

made with steel pipe to avoid the need for a fused joint in the wet trench should HDPE be used for the remainder of the alignment.

On the west side of Salmon Creek, an air valve/access manway is proposed at the high point. The pipe west of the Salmon Creek crossing to the Lake River crossing will be either steel or HDPE pipe. The effluent pipeline will cross under two existing utilities in this section: a fiber optic cable and a petroleum line. An access manway is proposed near the low point in the profile.

An air valve/manway is proposed at the high point just before the crossing of Lake River. The pipe for the crossing of Lake River will be steel. HDPE is not recommended for this section to avoid the need for a fused joint in a wet trench. On the west side of Lake River, an access manway is proposed for access and to allow dewatering of the low spot in the profile under Lake River.

On the west side of Lake River, an access manway is proposed approximately half-way between Lake River and Lower River Road. This pipe in this section will be either steel or HDPE. Just west of Lower River Road, a steel junction connecting to the existing outfall is proposed. This junction will include isolation valves, access manways, and air valves. The existing effluent pipe leading to the existing outfall will be abandoned at this point.

West of Lower River Road, the steel effluent pipe will continue to the outfall portion of the project in the Columbia River. An air valve/access manway is proposed at the point where the pipe profile dips down sharply to the river. The top of the air relief valve will be above the 500-year flood elevation for the Columbia River. A ball joint is proposed at the base of the steep slope to provide some opportunity for the pipe to move in the event unexpected erosion were to occur causing a loss of support around the pipe. A concrete revetment mat is proposed in the slope to help protect the pipe in the event that the steep slope continues to erode to the east away from the river.

The effluent pipe will continue along a relatively flat area with an elevation of about 3 feet. This section of pipe will be below the OHWE, but slightly above the 7Q10 elevation of approximately 2.1 feet. The profile of the effluent pipe will then drop rapidly with a slope of about 25 percent down to the elevation of the horizontal outfall pipe with ten diffusers. Ball joints are proposed at both the top and base of this slope. The steel outfall pipe will be supported on piles, but the effluent pipe will be supported by the native materials, in this area, primarily sand. The ball joints will allow a considerable degree of pipe flexibility if the native materials either settle or are partially moved by the river flow.

5.3 Effluent Pipeline and Outfall Hydraulics

The effluent pipeline and outfall have been designed as cement lined and coated 48-inch-diameter welded steel pipe. Hydraulics are based on CH2M 30 percent design drawings dated November 2017. There are two sections of the pipeline that can be either HDPE or cement lined and coated welded steel pipe. These sections are between Stations 68+69 and 46+47 and between Stations 41+50 and 19+22. For the pumping analysis, the scenario that creates the largest pump head is the one where the pipe material selected for these sections is HDPE. Even though HDPE piping is smoother than cement lined and coated welded steel pipe, the reduction of the hydraulic diameter of HDPE piping causes larger head loss. As a result, the hydraulic calculations below for pump sizing assume that HDPE piping is selected for the pipeline sections that have material options. Table 5-1 shows pipeline hydraulic data and roughness assumptions are provided in Appendix J.

Table 5-1. Hydraulic Data for Proposed Pipeline Materials*Engineering Report for the Phase 5A Project—Columbia River Outfall and Effluent Pipeline*

Pipe Size and Material	Hydraulic Diameter (inches)	Velocity at Buildout 72 mgd (ft/sec)
48-inch-diameter Welded Steel	48	8.9
48-inch-diameter HDPE (IPS SDR 32.5)	44.869	10.2

The proposed outfall configuration is a 48-inch-diameter cement mortar lined and coated steel pipe with ten 16-inch diffuser risers at 16-foot spacing, each riser fitted with an elastomeric check valve port. The diffuser section will extend 144 feet at an average water depth of approximately 42 feet below CRD at low river stage. The head loss in the diffuser manifold is based on a ProFlex SW check valves at each diffuser; the diffuser manifold head loss is shown in the Figure 5-1.

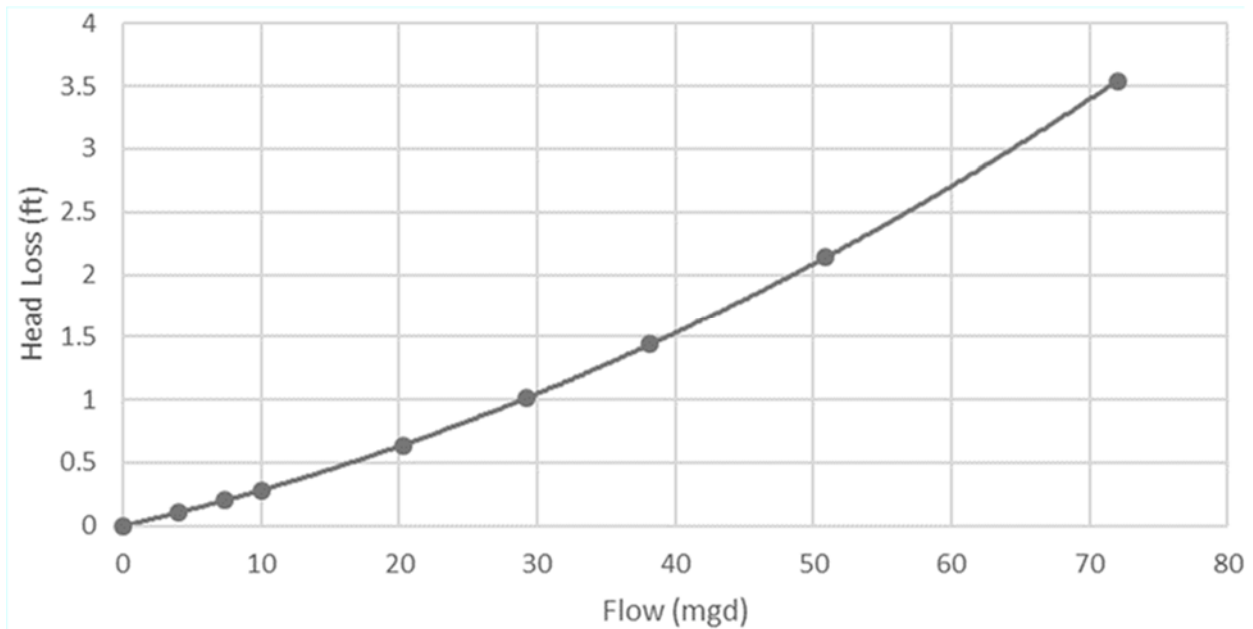


Figure 5-1. Diffuser and Manifold Head Loss
Flow (mgd) versus head loss (feet)

Engineering Report for the Phase 5A Project—Columbia River Outfall and Effluent Pipeline

Figure 5-2 shows the new 48-inch-diameter effluent pipeline system curves with one or more effluent pumps operating during 100-year flood river elevation (25.6 feet) conditions. These system curves assume HDPE piping is used for the two sections of the effluent pipeline where pipe material options are allowed. The figure also shows the existing 30-inch-diameter effluent pipeline with one pump operating. The system curves in Figure 5-2 depict the static head associated with the PUMP OFF elevation (24.18 feet).

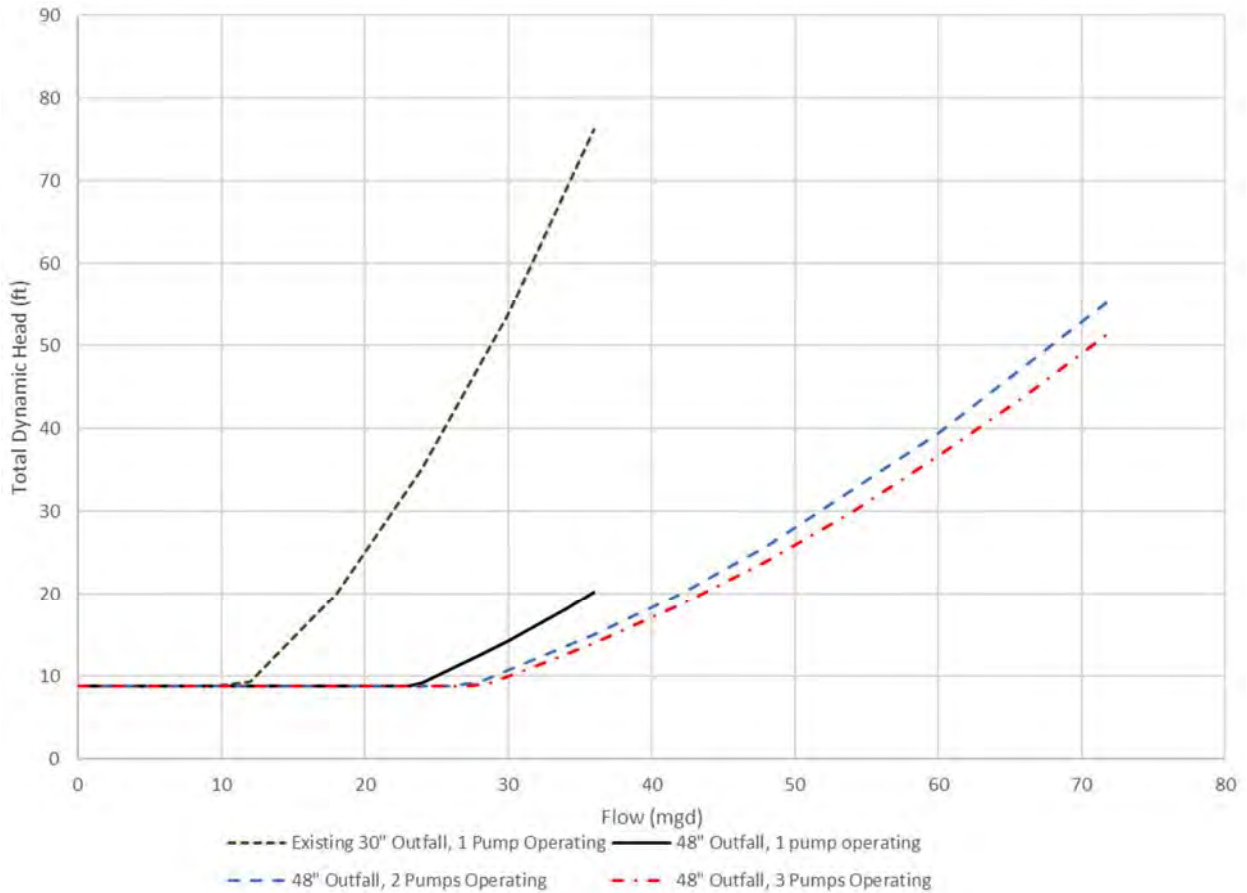


Figure 5-2. System Curves for Existing 30-Inch-Diameter and New 48-Inch-Diameter Pipelines
Assumes HDPE pipe sections
Engineering Report for the Phase 5A Project—Columbia River Outfall and Effluent Pipeline

The minimum total dynamic head for the system curves shown in Figure 5-2 is 8.8 feet. This corresponds to a difference in the elevations of the centerline of the pump discharge piping elevation (34.5 feet) and the PUMP ONElevation (25.7 feet). At this point, the effluent pumps lift the water up out of the wet well to discharge piping elevation were an air/vacuum valve will vent the pipe to atmosphere to avoid a vacuum condition and the liquid will flow by gravity through the effluent pipeline.

Table 5-2 shows the preliminary pump sections to be installed and commissioned with the new 48-inch-diameter effluent pipeline.

Table 5-2. Preliminary Pump Selection Data*Engineering Report for the Phase 5A Project—Columbia River Outfall and Effluent Pipeline*

Item	Data
Pump make and model	Fairbanks Nijhuis 24-inch –Model 8312-30-inch
Total number of pumps	4
Number of duty pumps	3
Number of standby pumps	1
Firm capacity (mgd)	3 pumps at 14.6 mgd each (43.8 total firm capacity)
Number of stages	2
BEP	89% @ 13.2 mgd
70% of BEP capacity (mgd)	9.3
120% of BEP capacity (mgd)	15.9
Motor size (horsepower)	75
Motor speed (revolutions per minute)	600
Pump column & discharge size (inches)	30
Pump bowl size (inches)	24
Discharge pipe and valve size (inches)	30

BEP = best efficiency point

Figure 5-3 shows one pump operating at 100-year flood river elevation. Although the pump capacity at 50 percent speed is approximately 4 mgd, the minimum gravity capability at 100-year food conditions is lower yet (3 mgd). However, if the PUMP ON level is raised to elevation 26.3 feet as stated above, the gravity capacity will be increased to 6 mgd. This overlap in gravity and minimum pump capacity will prevent effluent pump cycling and will provide a dead band between gravity and pumped effluent controls.

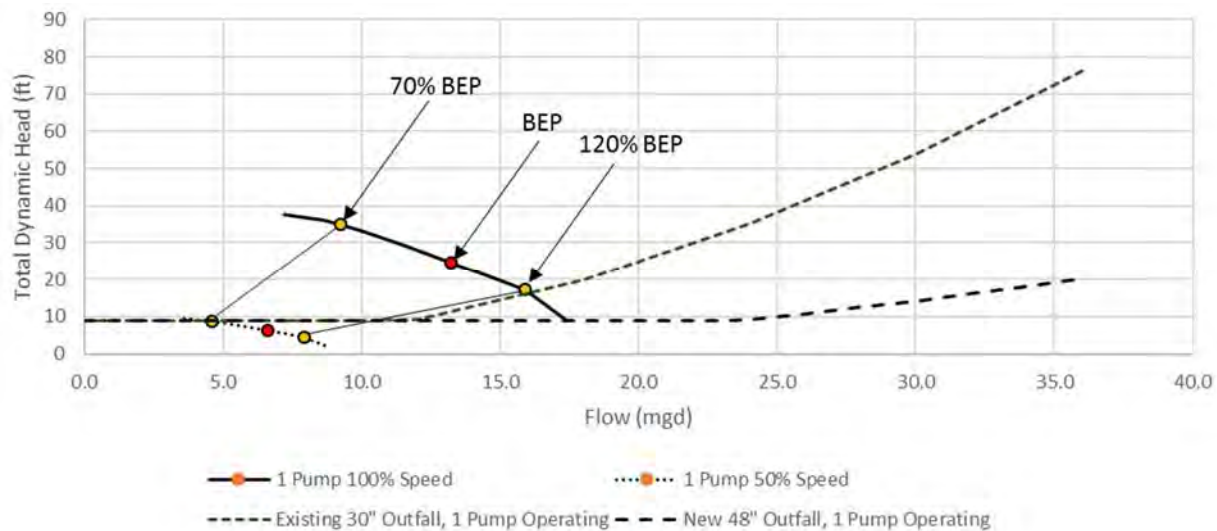
**Figure 5-3. One Pump Operating***System curve assumes 100-year flood river elevation**Engineering Report for the Phase 5A Project—Columbia River Outfall and Effluent Pipeline*

Figure 5-4 shows two pumps operating during 100-year flood river elevation conditions. The maximum capacity for two pumps running at 100 percent is approximately 33 mgd.

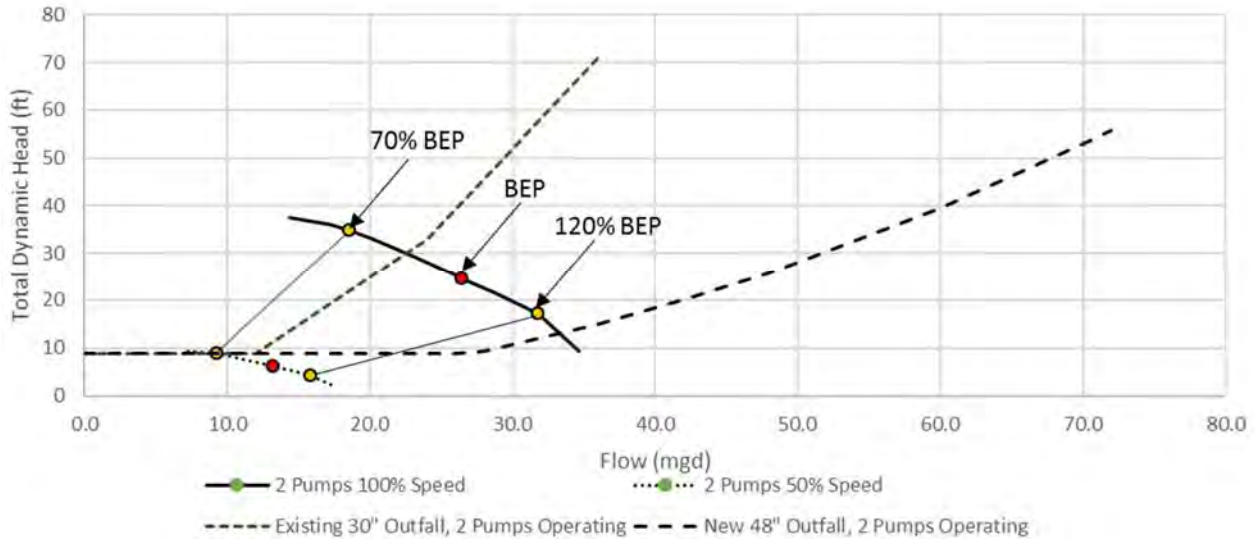


Figure 5-4. Two Pumps Operating
 System curve assumes 100-year flood river elevation
 Engineering Report for the Phase 5A Project—Columbia River Outfall and Effluent Pipeline

Figure 5-5 shows three pumps operating during 100-year flood elevation conditions. Maximum capacity of three pumps running at 100 percent is approximately 43.8 mgd with pump turn down approximately 15 mgd at 50 percent speed. This pump operating envelope is within the recommended 120 to 70 percent best efficiency point (BEP) flow range as shown.

As the design progresses, a surge analysis will be conducted to check transient pressures due to sudden pump shutdown caused by a power outage. It may be necessary to increase the size of the combination air/vacuum valves to minimize the surge pressures and the chance of vacuum conditions forming within the pipeline.

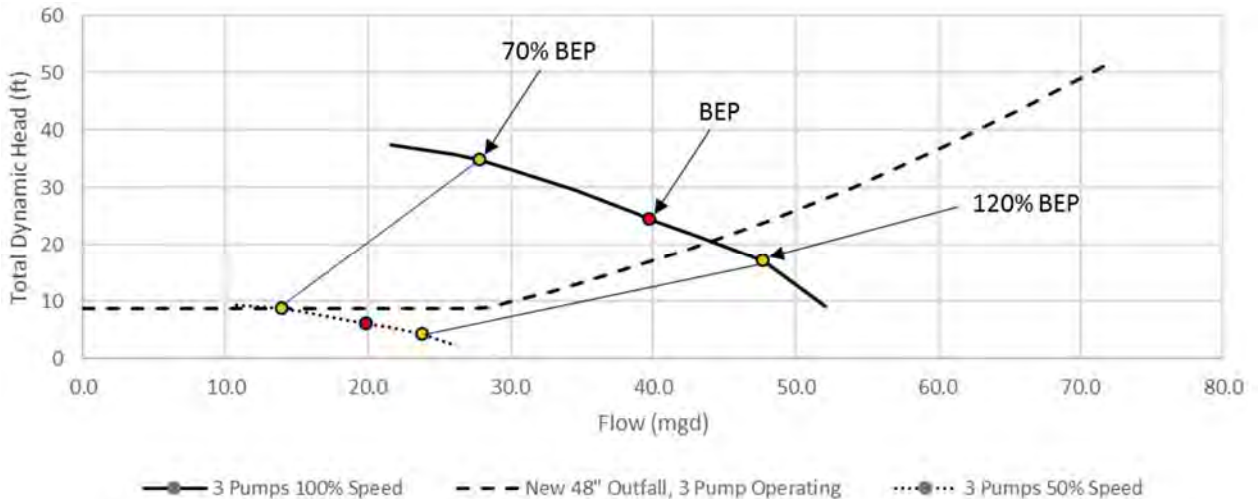


Figure 5-5. Three Pumps Operating
 System curve assumes 100-year flood river elevation
 Engineering Report for the Phase 5A Project—Columbia River Outfall and Effluent Pipeline

5.4 Construction Methods

This section provides a description of construction methods available along the route and those assumed for permitting of the pipeline and outfall. During the 30 percent design of the recommended alternative, various general, marine and trenchless contractors were contacted to discuss construction feasibility, listen to their recommendations for tunneling options, and discuss open cut feasibility and required areas available for staging and access. The following sections describe construction methods for each of the reaches of the pipeline.

5.4.1 Plant Site

Construction at the SCTP site will be open cut construction from the pump station to the auger bore shaft for the railroad undercrossing. It will require exposing the existing 30-inch-diameter effluent pipeline to make a connection to it. The connection will also require a line stop or a plug and a temporary bypass using the blind flange on the end of the pump station header and the existing 48-inch-diameter tee with a blind flange ahead of the 30-inch-diameter pipeline cross. The new connection and suggested location for line stops and bypass is depicted on design Drawing PS-01. Construction methods will likely need to include using sheet piles or shoring along the existing plant roadway access next to the steep slope to the Salmon Creek. Temporary erosion and sediment controls will be installed around the work zone perimeter. Dewatering water will be discharged to SCTP or a vegetated filter strip. Contractor staging will not be permitted within the Shoreline jurisdictional area. Upon pipeline completion, site drainage features will be restored and the surface revegetated according to conditions of the Shoreline Conditional Use Permit.

The SCTP will need to maintain road and turn-around access for biosolids hauling trucks during construction. The frequency of hauling trucks can be as high as 12 to 18 trucks a day from August 1st to September 30th, to as low as 0 to 3 trucks a week during midwinter to early spring (December 1st to April 1st). Outside of these dates, the expected hauling truck frequency is estimated at 1 truck per day.

Contractor staging and activities will be limited to not affect traffic in the roadway area as this is an essential and busy traffic route for plant solids handling operations.

5.4.2 Railroad Undercrossing

Construction of the railroad undercrossing, depicted in Drawing PP-06, will use a trenchless construction method, auger boring, to install the required steel casing under the railroad tracks. Access restrictions to the west side of the BNSF embankment significantly limit the available trenchless techniques to methods that do not require launch or recovery of major tunneling components from the west side.

The auger boring will consist of installing a casing by augering a borehole horizontally from the launching shaft to a receiving pit while simultaneously jacking the casing into place behind the leading end of the auger. In this sequence of augering and jacking the casing, the augered hole is supported by the casing. The augering operation is monitored at the shaft, where the cuttings or spoils are removed from the pipe via continuous flight augers that rotate inside the jacked casing. The vertical alignment of the casing will be monitored using a water level arrangement or by periodically using a laser or theodolite and electronic distance measurement device within the casing (after removing the augers). Steering is limited with this method, and the expected accuracy can be less than 1 percent over the length of the bore.

Given access restrictions to the west side of the BNSF railroad embankment, it is anticipated that the contractor would choose to install the casing under the railroad in a downward direction from the east side. The disadvantage is that any groundwater encountered would not drain from the leading end of the casing. There is an elevated risk of inundating the auger boring tunnel face and binding the augers in sands below the water table; however, the predominantly silty materials are low in plasticity and should

not clog the augers. The technique of carrying a soil plug at the leading end of the casing is recommended to provide a barrier to reduce the risk of unanticipated flowing sands entering the casing. As long as an adequate soil plug is maintained, issues are not anticipated with the presence of a limited zone of soft silts on the west side of the embankment, and are not anticipated beneath the embankment. There are no tunneling machines to recover with the auger boring method.

Auger boring in saturated sands carries a high risk of flooding the casing with flowing sand, which may cause the auger boring equipment to become stuck underground. Rescue would require significant dewatering for personnel entry into the tunnel (high safety risk) or for a rescue shaft, which would be challenging given the presence of the railroad embankment. If equipment retrieval were not possible, it would be abandoned in place and a new crossing would have to be attempted.

As described in the Salmon Creek Crossing (Section 5.4.3), a temporary trestle/work platform may be needed from the Curtis Lake Ranch property to access the site between Salmon Creek and the base of the railroad embankment.

The method requires construction of a launching pit on the east side of the embankment from which to advance the casing and augers. Dewatering is likely required at the east end of the crossing and specifically during launch of the casing. The pit could be completely or partially shored, per contractor preferences. On the west side of the embankment the casing can be received in the excavation for the open cut pipeline, and the augers withdrawn to the launch pit. Shoring will be installed at the receiving pit on the west side of the embankment to prevent excessive movement or settlement of the slope below the BNSF railroad. In addition, a survey monitoring program will be established to monitor the slope and railroad during trenchless work.

Once the casing is in place, the carrier pipe will be installed and centered using casing spacers. For steel pipe, individual lengths of pipe will be welded and progressively pushed into the casing. For HDPE carrier pipe, the pipe segments will be butt-fused outside the launch pit, and then pulled into the casing using a winch on the west side in combination with excavator-supported slings to support the pipe on the east side. Installation of the HDPE pipe within the casing will require an approximately 100-foot-long tapered tail excavation to accommodate the minimum bending radius of the pipe as it is bent into an S-shape from the ground surface down to the elevation of the casing in the pit. Depending on the alignment to the east of the launch pit, this tail trench could be accommodated within the adjacent open cut pipeline excavation. A small air release pipe will be routed from its penetration into the top of the main pipeline immediately west of the end of casing, through the annular space between the casing and pipeline, to the air/vacuum valve and manhole located on the east side of the railroad crossing. The annular space between the casing and effluent pipe will be grouted and end seals installed to eliminate a potential pathway for groundwater movement.

Spoils generated as the auger boring machine advances to install the steel casing will be collected in the launching pit and periodically lifted out using a crane and cleanout bucket. The spoils will either be placed directly in a dump truck to be hauled offsite, or first stockpiled at the surface before being loaded into a dump truck for removal from the site. Because drilling fluids are not used with the auger boring approach, it is not expected that any dewatering of spoils, nor any special treatment of the spoils will be needed.

Full containment will be placed around the launch pit and staging area during construction. The launch site will be restored to preconstruction grades and revegetated according to conditions of the Shoreline Conditional Use Permit. The staging area will be located outside the Shoreline jurisdictional area, as much as practical. Protection of archaeological resources will follow procedures approved by USACE and the Washington State Department of Archaeology and Historic Preservation.

5.4.3 Salmon Creek Crossing

While there are several alternative construction methods for installation of the effluent pipeline beneath Salmon Creek (and Lake River), preliminary discussions with WDFW and the USCG, place restrictions on the crossing methods that will be permissible. Regulatory agencies require that specific construction methods be described in permit applications, limiting contractor flexibility for modifying the construction approach to address field conditions without prompting re-initiation or further review of the permitting processes.

Floating silt curtain or other turbidity control measure(s) will be installed before conducting any in-water work that may disturb the streambed. The silt curtain will be installed around individual work areas or disturbance points, while maintaining fish passage and acceptable vessel navigation, and avoiding flood hazards, without the need for bypass pumping or fluming of stream flows around the work area.

The seasonally shallow water of Salmon Creek prevents mobilization of a deep-draft barge to the work site during the anticipated in-water work window. Therefore, it is expected that the contractor will utilize a temporary work trestle/platform. The work trestle will be constructed from the right bank (west side) of the creek and progress easterly. The trestle will be constructed by driving temporary steel piles into the ground or stream bottom to form bents that will be 40 to 50 feet apart to allow vessel navigation and woody debris passage. Piles driven or proofed using an impact hammer may necessitate sound attenuation mitigation (e.g., bubble curtain) to reduce hydroacoustic impacts to fish. A sealed work deck will be placed across abutments and bents for complete containment. Depending on USCG Bridge Permit requirements, it may be necessary to construct the working trestle with a removable span that can be removed to allow for passage of boats or personal watercraft. If this is the case, a dedicated crane may be required to ensure the removable segment can be lifted on short notice.

Because fish passage and vessel traffic must be maintained, a construction approach using a split-river cofferdam system will be used. This approach involves installation of a cofferdam across a portion of the stream, construction of the pipeline within the cofferdam, followed by moving the cofferdam to the other side of the stream to allow for construction of the remaining portion of the pipeline to complete the stream crossing while keeping one side of the river open at all times.

The sequence of construction of the crossing of Salmon Creek will be determined by the contractor. However, it is expected that the pipeline will be installed across the eastern portion of the stream first, followed by installation across the western portion of the stream. For this sequence, the cofferdam system will be installed from the work trestle initially across the eastern portion of the stream. After obligatory fish salvage from within the cofferdam, soil will be excavated from within the cofferdam down to the required trench subgrade elevation. Excavation of soil can be accomplished either “in the dry” (by dewatering) or “in the wet;” determination of which method to use will be left to the contractor. Dry excavation requires the inside of the cofferdam to be dewatered, which necessitates that the joints of the cofferdam to be sealed to minimize leakage. It also requires treatment of the water pumped from inside the cofferdam, and likely increased internal bracing because removing the internal water reduces the water pressure inside the cofferdam that helps to resist buckling and displacement resulting from the external soil and water horizontal loads. If the pipeline trench is excavated in the wet, the spoil materials will be removed from within the water column and will therefore have an elevated water content, which can make it more difficult to prevent sediment and turbid water from entering the stream and to temporarily store or stockpile the material without return water. It is also more difficult to excavate the trench and verify that the trench has been excavated to the proper depth when the excavation is completed in the wet.

Pipeline segments to be installed across the stream will be welded up and tested on land and then moved into place once the excavation inside the cofferdam is complete. Once in place, the pipeline segment inside the cofferdam will be sunk into place and backfilled, leaving only the mid-creek end of

the segment exposed to allow it to be joined to the final segment of pipeline to complete the crossing. With the initial pipeline segment in place, the floating silt curtain and cofferdam will be removed and repositioned to allow for installation of the final segment of pipeline to complete the crossing. Installation of the western portion of the pipeline will follow the same procedures used to install the initial portion of the pipeline crossing.

A critical aspect of the stream crossing construction is joining the two segments of pipeline near the center of the stream. This connection should be made in the dry to allow for control of the work and proper inspection and testing. The contractor can use different methods to dewater the area where the pipeline segments will be joined. The area around the now-installed pipeline must be sealed so that seepage around the pipeline does not flood the work area. One method that can be used to make the critical connection is to install a tie-in box at the location where the connection will be made before installing the pipeline segments. The tie-in box can be constructed using sheet piles or can be a prefabricated concrete box section. Cutouts in the tie-in box allow the pipeline segments to be threaded through the walls of the box, and the cutouts must be capable of being sealed once the pipeline is installed. With the pipeline installed and the cutouts sealed, the tie-in box can be dewatered to allow for the final connection of the two pipe segments to be made, inspected, and tested. Following the connection, as much of the tie-in box as possible will be removed, without leaving an obstruction or fish trap in the streambed.

After the effluent pipeline is installed and joined across the river and the tie-in box removed, the temporary work trestle will be removed. The banks of the stream will then be restored using bioengineering techniques, and the silt curtain removed.

5.4.4 Lake River Crossing

The effluent pipeline crossing of Lake River will progress in a similar manner to that described for the Salmon Creek crossing. The main difference is that the increased water depth in Lake River allows for at least a portion of the work to be completed from barges. However, the selected contractor will determine how best to approach in-water work based on available equipment, river conditions, and regulatory constraints. If a temporary work trestle is used, vessel navigation must be accommodated by either maintaining 35 feet of vertical clearance or installing lower work platforms from each riverbank that access only half the river width at a time.

5.4.5 Farmland Crossing

The pipe will be installed by open trenching where it crosses farmland and adequate work space is available for operation of equipment, pipe storage, excavated material storage, and hauling of materials. Some dewatering of the trench may be required. It is anticipated that the contractor will use a trench box for worker safety. Suitable pipe zone bedding and pipe zone material will be placed in trench and compacted to bed and support the pipe. This material could be either imported material or native material excavated from the trench (if the moisture content and native soil type are suitable). Above the pipe zone, it is anticipated that native material will be used for trench backfill. If the excavated material is not suitable for topsoil, the existing topsoil will be excavated and stored separate from the other excavated materials. The stored topsoil will then be replaced as the last of the trench backfill. After the trench has been backfilled, the disturbed area will be reseeded.

5.4.6 Wetland Crossings

Permanent structures such as access vaults and air valves will be sited outside wetlands. An unavoidable permanent wetland fill will occur at approximately Station 66+00 to provide sufficient cover over the pipe. Staging areas and dewatering facilities will be located outside wetlands. Temporary wetland impacts will be unavoidable for trench excavation and construction access. However, temporary impacts

will be minimized by specifying trench shoring for excavation and designated narrower access to reduce the construction footprint. Wetland topsoil will be salvaged for reapplication over the backfill surface. Wetland vegetation is expected to regenerate naturally from the salvaged wetland topsoil.

Trench plugs, consisting of low permeability trench backfill, will be installed at periodic intervals along the pipeline alignment to prevent water from flowing along the pipeline and eroding trench backfill materials and to minimize the potential for groundwater flow through the trench backfill. Where the pipeline trench crosses a wetland, trench plugs will be installed as necessary to maintain the original wetland hydrology. Trench plugs will be installed on both sides of the wetland boundary, between the wetland and adjacent upland area. Trench plugs will be keyed into the trench sidewalls and trench bottom.

5.4.7 Round Lake Conservation Bank Crossing

The Round Lake Conservation Bank (Bank) has been proposed by the New Columbia Garden Company on Parcel 191177000, where the existing effluent pipeline easement lies and where new temporary and permanent easements will be acquired. The Bank project involves creating, restoring, and enhancing fish and wildlife habitat by breaching the levee at two locations along the Columbia River, filling drainage ditches, constructing tidal floodplain channels, creating and restoring wetlands, and planting native vegetation. If effluent pipeline construction precedes Bank construction, the property within the existing and acquired easements will be restored to preconstruction conditions. If effluent pipeline construction follows Bank construction, the easements will be restored to conditions consistent with the regulatory conditions for the Bank.

5.4.8 Outfall Construction in the Columbia River

Construction of the outfall for the effluent pipeline will involve marine construction with near shore work being completed from land and a temporary work trestle/platform extending offshore in shallow water. A partial (open-ended) floating silt curtain will be installed around the excavation area in shallow water, up to a 20-foot depth. Construction within deeper water will be accomplished from barges without a turbidity curtain.

Immediately before the outfall section, a concrete revetment mat will be placed as the trench is constructed. A wide sloped area will be excavated at an angle to the trench alignment in order to place the mat. The mat will then be buried with native materials as the trench is backfilled and completed, and permanent markers placed at the top edge of the mat for future reference.

The near shore and shallow water outfall pipeline trench will be excavated to the required depth using either an excavator or clamshell dredge using an ecology bucket. Limited sidecasting of trench spoils downstream of the trench excavation may be possible to limit the need to raise the spoil material through the water column. However, complete sidecasting of spoils may not be possible because the existing effluent outfall downstream of the proposed outfall needs to remain operational through new construction. Therefore, a portion of the excavated spoils will likely need to be lifted to the surface and placed directly onshore, or placed on a barge and moved offsite for permanent disposal.

Excavation of the outfall trench and placement of the new outfall pipeline will proceed from the shore into the river. Steel pipe piles will be installed to support the diffuser section of the outfall. Pipe piles will be vibratory-driven in pairs and spaced at about 15 feet on-centers. A precast concrete pile cap with a saddle to support the outfall pipe will be placed over each pipe pile pair. Once the outfall pipe is in-place, it will be connected to the pile cap using a pipe strap bolted or embedded into the pile cap.

The outfall pipe will consist of steel pipe with mechanical couplings and Carnegie-style bell-and-spigot gasketed joints. The use of mechanical couplings will allow the pipeline to be constructed in segments that can be picked up and lowered into place using a trestle- or barge-mounted crane. Divers and

remotely operated underwater vehicle equipment will be used to help position each stick of pipe, fit it up with the previously installed pipe, and tighten the mechanical couplings to seal the joint. Where diffuser risers extend from the outfall pipe, the diffuser riser will be welded to the pipe, tested, and coatings applied in the shop before bringing the segments to the site. The pipe segment with attached diffuser riser will be positioned using cranes and divers in much the same way that standard pipe segments are positioned and joined.

The outfall pipeline trench will be backfilled with granular bedding and pipe zone material. This backfill material will cover the top of the pipeline. Angular stone or riprap will be placed above the granular backfill to provide protection against erosion that could otherwise expose the outfall pipe. Spoil material from the pipe trench excavation will be placed to backfill the upper portion of the pipeline trench. The native sand will restore the bottom of the river and cover the granular backfill materials. Bioengineering techniques will be applied for riverbank restoration.

5.4.9 Navigation Marker

The ultimate configuration of the PATON (i.e., three-pile dolphin navigation marker at the end of diffuser) has not yet been determined, but will be finalized in consultation with the USCG. The existing three-pile dolphin might remain, or it could be replaced with a dolphin or buoy at the new diffuser, or removed without replacement. USCG approval will be required if the marker is relocated. A navigation marker is needed to warn and divert any river traffic away from the diffuser area, which might otherwise be at risk of damage from tug chains or small craft anchors.

If a new navigation marker is added, it will be constructed using steel pipe pile. A template will be constructed to maintain the position of each individual pile as they are installed. The pile will be positioned and installed using a vibratory hammer, which will reduce hydroacoustic impacts to fish. An impact hammer will only be used if the required embedment depth cannot be achieved using a vibratory hammer. Hydroacoustic impacts to fish associated with the use of an impact hammer will be mitigated with the use of a bubble curtain or other attenuation mitigation measures. Once the individual pipe piles are installed, cross bracing, maintenance ladder, and warning markers will be installed.

5.4.10 Removal of Existing Outfall and Effluent Pipe near the Columbia River

If necessary, the existing outfall and effluent pipeline will be removed after the new outfall is operational. Removal of the outfall will involve marine construction with near shore work being completed from land and/or a temporary work trestle/platform extending offshore in shallow water. A partial (open-ended) floating silt curtain will be installed around the excavation area in shallow water, up to a 20-foot depth. Construction within deeper water will be accomplished from barges without a turbidity curtain.

Removal will consist of excavating soil and backfill material to expose the existing pipeline and diffusers. Native soil removed from the excavation will be sidecast downstream of the excavation. Riprap and quarry stone used for scour protection and trench backfill will be lifted to the surface and placed directly onshore, or on a barge. These materials will be utilized onsite or moved offsite for reuse or permanent disposal.

If necessary for removal of the effluent pipe, divers will be used to cut the straps that secure the pipe to existing pile caps. If possible, the pile caps will be removed with the pipeline. If the pile caps cannot be removed without disturbing the supporting timber piles, the caps will be left in place where they will be buried to a depth of at least 4 feet upon backfilling the trench. Existing treated and untreated timber piles supporting the existing outfall diffuser pipeline will be left in place since they will be buried to a depth of at least 5 feet once the trench is backfilled.

Native sand material obtained from excavation of the trench for the proposed or existing effluent pipeline and outfall will be used to backfill the trench after the existing outfall pipeline is removed.

In addition to removing the existing outfall, the existing effluent pipeline between the outfall and the existing manhole on the shoreline of the Columbia River will be removed. The removal of this section of effluent pipeline will be accomplished using tracked or rubber-tired excavation equipment working from the land. The pipeline will be exposed and removed in segments. To the extent possible, non-native trench backfill material will be separated from native materials. Native material will be used to backfill the trench after the pipeline is removed, while non-native material will be removed from the site and reused or disposed of.

5.4.11 Access and Staging

Existing roads will be used for contractor access as possible (reference Drawing D-05). The private, paved Lower River Road will be used to access the New Columbia Garden (Fazio) property along the Columbia River and between the Columbia River and Lake River. The paved NW McCann Road will be used to access the SCTP and pipeline east of Salmon Creek. NW 169 Street and NW 61st Avenue will be used to access the Curtis Lake Ranch (Meyer) property.

Entry onto the Meyer property must either use an existing railroad undercrossing or an at-grade, un signaled railroad crossing. The railroad undercrossing can accommodate only regular passenger vehicles and small trucks. The at-grade railroad crossing can accommodate large equipment and semi-trailer trucks, but may require profile and turning radius improvements or re-alignment for large trucks to safely pass. The Meyer property has a network of existing unpaved farm roads, many of which will require load-bearing improvements with geotextile and gravel (as shown in Drawing D-04) to extend operability for contractor employees and equipment traffic during wet weather. Roads will be delineated through environmentally sensitive areas.

The at-grade railroad crossing is critical for moving equipment and materials to the pipeline construction area; however, its use is contingent on approval by the BNSF Railway Company, which operates frequent freight and passenger trains. If the BNSF Railway Company limits access at the at-grade railroad crossing, alternate access to Curtis Lake Ranch would be pursued. One alternate method of equipment and materials access would be via barges on Lake River with a landing at the effluent pipeline easements. Another alternate method would be via NW Lower River Road and the New Columbia Garden property, over Lake River by temporary work bridge, to the pipeline construction limits on the Curtis Lake Ranch property. (A temporary work bridge would require water permits from USACE and WDFW, and a Bridge Permit from the USCG.)

Access will also be available within the temporary and permanent pipeline easements, which are shown on the plan and profile sheets (Drawings PP-01 through PP-07). Generally, the permanent easement for the existing pipe is 20 feet. Parallel to this easement, 40-foot permanent easements for the new pipe will be accessible for construction, as well as additional 60-foot-wide temporary construction easements. Easements will be wider at the approaches to Columbia River, Lake River, and Salmon Creek where additional space is needed to maneuver construction equipment.

Contractor work areas and staging areas have been identified and depicted on design Drawing D-05. The staging and work areas will be located in key areas at the river crossings and along the pipeline for the contractor to manage construction, store materials, and access the pipeline. Soil and vegetation disturbance within the Shoreline jurisdictional areas will be minimized to the extent practicable.

Some access roads (mostly existing farm roads) will require improvement for construction activities and related truck traffic widths and turning radii. Staging areas will need to be equipped for spill prevention, containment, and countermeasures.

Rehabilitation of these areas and all areas within the construction limits will be performed to return them to preconstruction conditions. Rehabilitation may include decompacting soils through disking, tilling, and seeding; or reapplication of stripped topsoil on disturbed farmland. Temporary geotextile and gravel will be removed from staging areas and existing farm roads, unless avoidance of an adverse flood hazard effect can be demonstrated. Lower River Road may require rehabilitation after pipeline construction.

5.5 Effluent Pump Station Improvements and Phasing

5.5.1 Phase 5 Pump Station Improvements

The four existing pump slots will be replaced with new vertical line shaft pumps. The initial pump replacements will be four equally sized pumps with a firm capacity of 43.8 mgd. This will give the effluent pump station enough capacity through 2013 Facilities Plan Phases 5 (PHF 36 mgd) and 6 (PHF 43 mgd). Table 5-2 above shows the preliminary pump selections to be installed and commissioned with the new 48-inch-diameter effluent pipeline.

5.5.2 Pump Station Control System

Refer to Section 4.5.2 for pump station control system.

5.5.3 Constructability Sequencing and Provisions

The pumps will be replaced one at a time to keep the pump station in service at all times. Pump replacement may be constrained to dry weather season to ensure that gravity effluent flow is possible.

5.6 Design Criteria Summary

Table 5-3 summarizes the design criteria for the SCTP outfall and effluent pipeline for the project.

Design Element	Design Criteria	Design Implementation
Effluent Design Flows	Peak hour effluent flow at buildout (72 mgd) Dry weather maximum day flow at buildout (37.3 mgd) Wet weather maximum day flow at buildout (50.9 mgd) SCTP effluent pump station improvements (43.8 mgd)	Flow Characteristics (Section 3.1), Effluent Pipeline and Outfall Hydraulics (Section 5.3), and Effluent Pump Station Improvements and Phasing (Section 5.5)
Design Vertical and Horizontal Datum	Horizontal datum is Washington State plane coordinates (South Zone, NAD83 (2011)) Vertical datum (feet) is NGVD29	Civil and Hydraulic Designs (Sections 4 and 5) and Design Drawings (Section 5.7)
Pipeline Route Criteria	Parallel alignment to existing SCTP pipeline Separation and offset requirements Use of existing negotiated easements and utilities avoidance Access to pipeline for construction and O&M Soil, groundwater, wetlands and cultural resource conditions on route Construction methods feasibility	Effluent Pipeline Design (Section 4.3), Pipe Materials and Pipeline Elements (Section 5.2), Construction Methods (Section 5.4), and Design Drawings (Section 5.7)
Pipeline Design Criteria	Pipe materials for minimum 50-year life span Pipe support requirements using native soils and imported backfill	Effluent Pipeline Design (Section 4.3), Pipe Materials and Pipeline Elements (Section 5.2), Effluent Pipeline and Outfall Hydraulics (Section 5.3),

Table 5-3. Summary of Design Criteria for SCTP Effluent Pipeline and Outfall Project <i>Engineering Report for the Phase 5A Project—Columbia River Outfall and Effluent Pumping</i>		
Design Element	Design Criteria	Design Implementation
	Pipe protection on river shoreline use minimum burial depth to crown (10 feet) and buried concrete revetment mat Combination air/vacuum release valves at high points along pipeline Pipeline inspection manholes for internal pipe inspections	Construction Methods (Section 5.4), and Design Drawings (Section 5.7)
Outfall and Diffuser Site and Design	Hydraulic capacity, head loss limits, and discharge velocity Dilution requirements to meet water quality standards with safety factor Structural stability of river outfall and diffuser pipe Design to accommodate river bedform dynamics and bank erosion Navigation marker (lighted) to protect diffuser in river	Water Quality Standards and Design Dilutions (Section 3.3), Outfall and Diffuser Design (Section 4.4), Effluent Pipeline and Outfall Alignment (Section 5.1), and Effluent Pipeline and Outfall Hydraulics (Section 5.3)
Pipeline and Pump Hydraulics	100-year flood river elevation (25.6 feet, NGVD29) Four effluent pumps (allow one pump out of service for reliability and redundancy) Effluent flows > 36.2 mgd must be pumped regardless of river elevation	Effluent Pipeline and Outfall Hydraulics (Section 5.3) and Effluent Pump Station Improvements and Phasing (Section 5.5)
Safety Factors	Steel pipe to AWWA standards and Manual 11 guidelines for steel (a minimum of 2 for internal pressure) HDPE pipe to AWWA standards and Manual 55 guidelines HDPE pipe Outfall pipe minimum burial depth to crown in river (8 feet) Diffuser dilution factors at buildout effluent flow and at critical river discharge conditions of 100 percent to meet acute and chronic aquatic life criteria	Water Quality Standards and Design Dilutions (Section 3.3), Civil and Hydraulic Designs (Sections 4 and 5) and Design Drawings (Section 5.7)
Connection to SCTP	Minimize removal of existing 30-inch effluent pipeline Minimize head loss Allow for effluent flow conveyance through existing or new pipeline Thrust restraints against unbalanced hydrostatic forces Minimize duration of flow shut-downs to make new pipeline connections	Civil and Hydraulic Designs (Sections 4 and 5) and Design Drawings (Section 5.7)

5.7 30 Percent Design Drawings

The 30 percent design drawings for the Phase 5A Project—Columbia River Outfall and Effluent Pipeline are provided at the end of this section.

5.8 O&M and Staffing

The Phase 5A Project seeks to minimize future O&M inputs. Manhole access, valve types, and valve locations have been designed with input from staff at the SCTP to minimize future O&M resources. See Section 4.1.5 for pipeline design criteria.

The pipeline materials have been selected to provide a service life of at least 50 years.

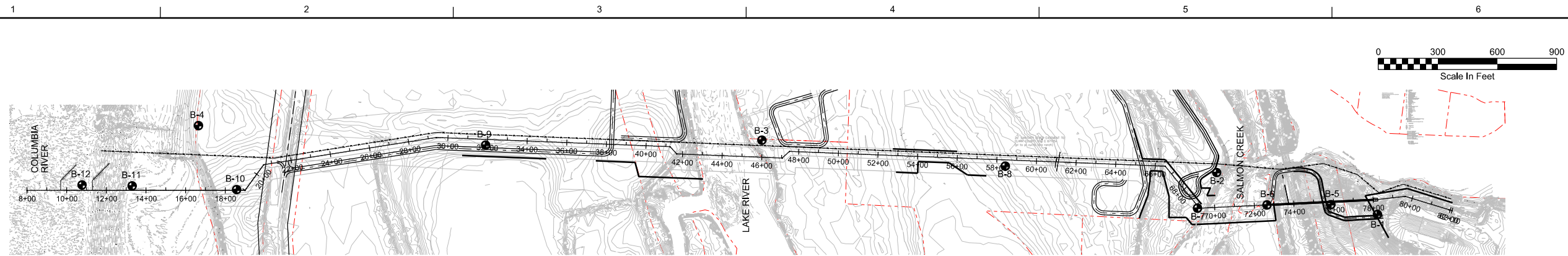
The new system will include inspection points that will facilitate anticipated future inspection needs. Several 24-inch-diameter access ports (manholes) will be provided along the alignment of the 48-inch-diameter effluent pipeline for access by maintenance staff to inspect the pipe joints and lining either by personnel entry or CCTV equipment, make repairs to the lining if necessary, and to lower a pump into the pipe for dewatering.

Two access locations will be provided in the section of pipe with the diffuser. A blind flange will be provided on the downstream end of the 48-inch-diameter diffuser pipe, and the most downstream diffuser will include an access port. These entry points can be accessed by a diver if necessary to perform inspections or repairs.

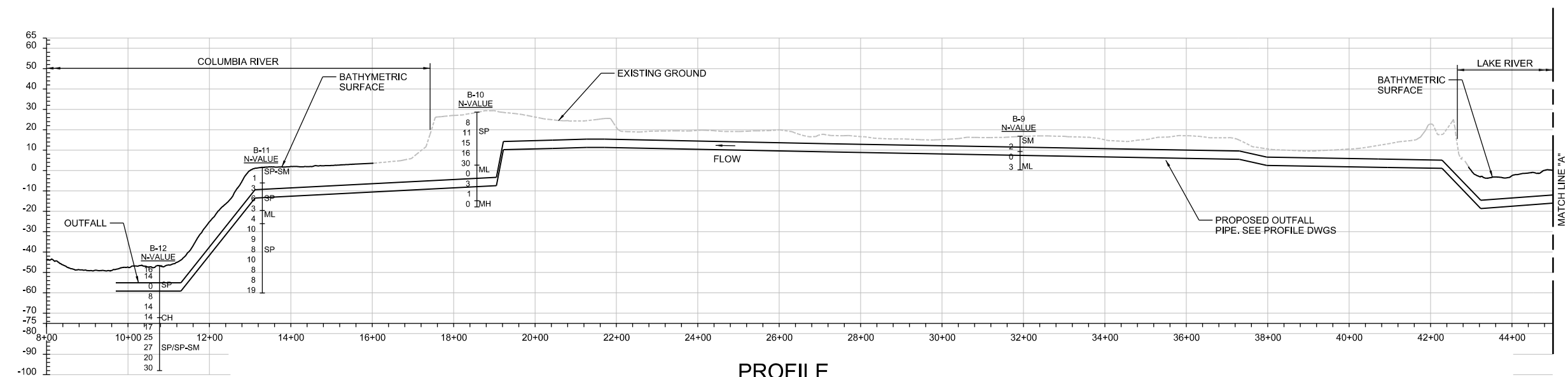
Drain valves (i.e., blowoffs) were considered to allow complete draining of the pipe for future inspection. However, the 30 percent design does not include blowoffs because submersible pumps lowered from the strategically-placed access ports are sufficient to dewater the effluent pipeline.

Combination air/vacuum release valves will be provided at the high points in the profile and at other points where air may accumulate during operation. They will be located where vehicles and equipment can access them during periods of high water. Enclosures commonly used for air valves will include rectangular precast vaults with access ladders and dual hatches that allow natural light and adequate working space for maintenance crews.

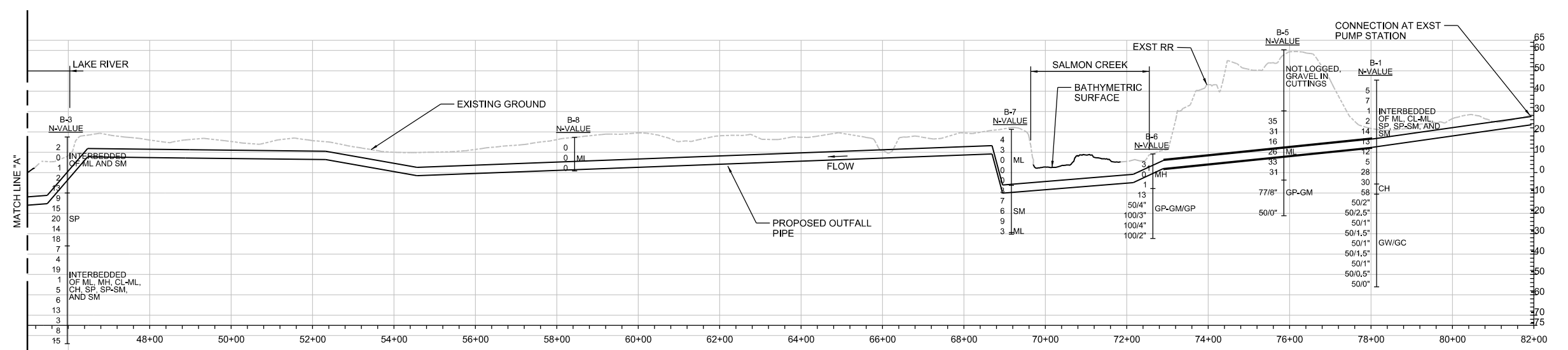
The existing 30-inch-diameter effluent pipeline from the SCTP up to the proposed junction structure at NW Lower River Road will be retained and valving added to facilitate dewatering of the new effluent pipeline for periodic maintenance inspections, and as an emergency bypass in the unlikely event of need of repairs. The Phase 5A Project will not require additional staff or training to operate and maintain the new effluent transmission system. The new effluent pipeline, outfall diffuser, and replacement effluent pumps will use technologies and materials similar to those existing.



PLAN
1"=300'



PROFILE
1"=150' HORIZ, 1"=30' VERT



PROFILE
1"=150' HORIZ, 1"=30' VERT

NO.	DATE	DR	CHK	REVISION	BY	APVD
		B. THOMPSON	D. SUNSERI			R. BEIELER
						Q. COTTEN

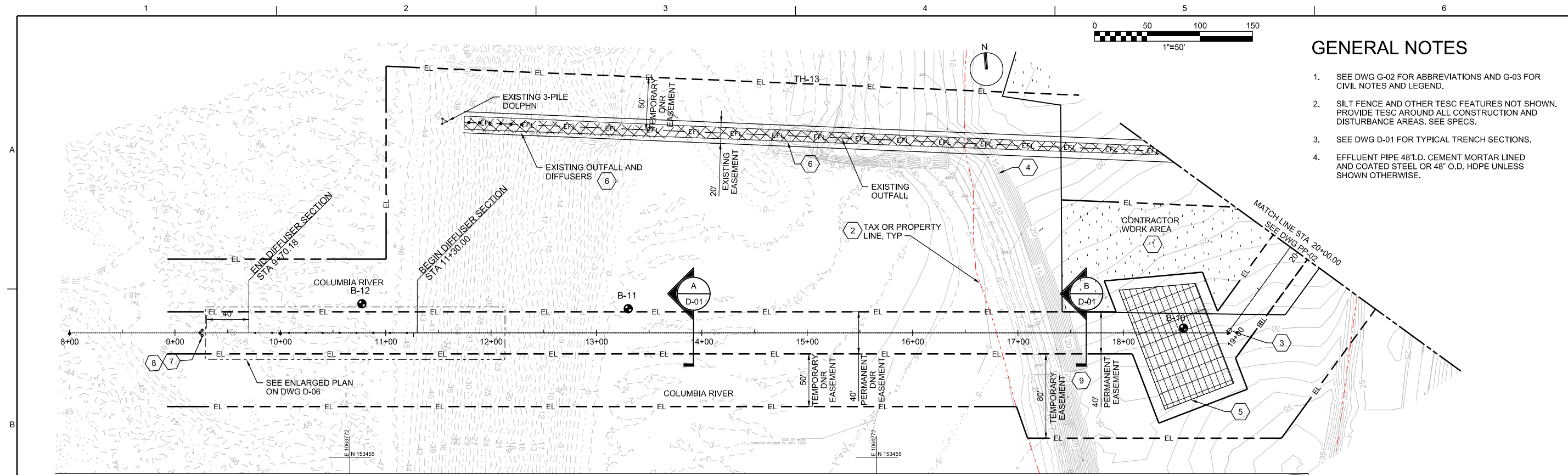
Project 92-2016-0023
Columbia River Outfall and Effluent Pipeline Project
Discovery Clean Water Alliance
Clark County, Washington

ch2m
GENERAL
GEOTECHNICAL INFORMATION

VERIFY SCALE	BAR IS ONE INCH ON ORIGINAL DRAWING.
DATE	FEBRUARY 2018
PROJ	663264
DWG	G-05
SHEET	5 of 26

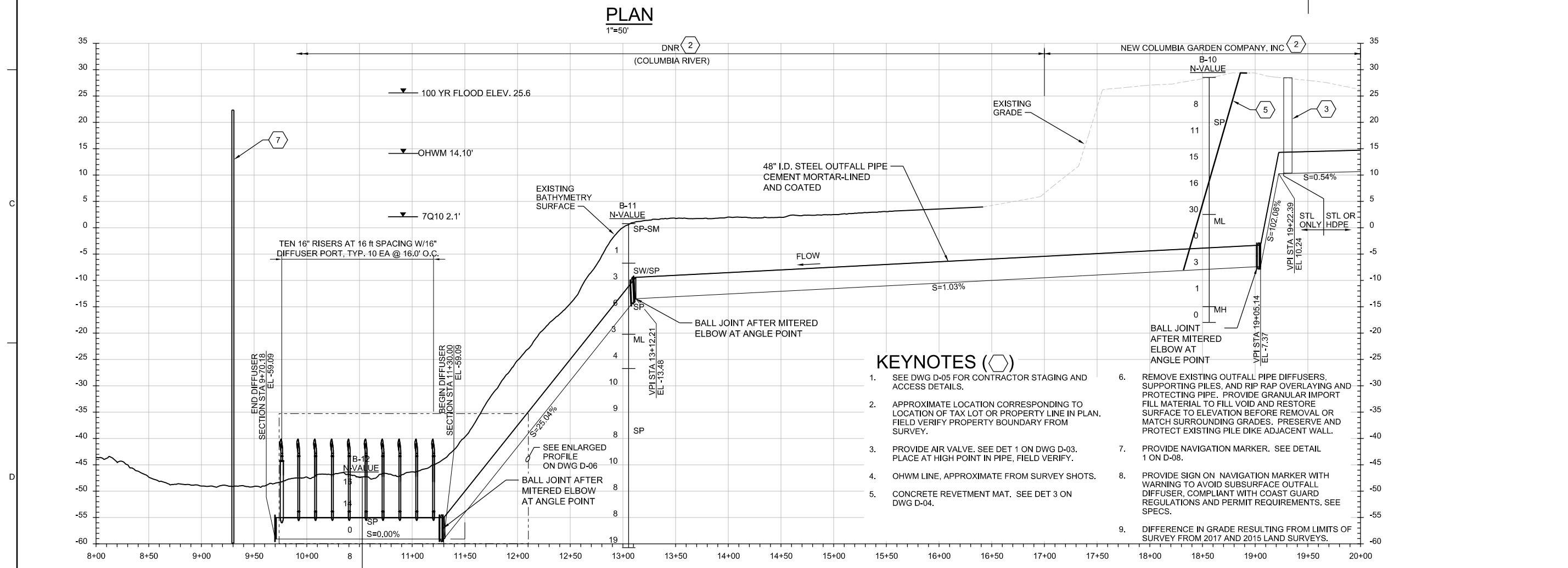
30% DESIGN SUBMITTAL

© CH2M HILL 2018. ALL RIGHTS RESERVED.



GENERAL NOTES

- SEE DWG G-02 FOR ABBREVIATIONS AND G-03 FOR CIVIL NOTES AND LEGEND.
- SILT FENCE AND OTHER TESC FEATURES NOT SHOWN. PROVIDE TESC AROUND ALL CONSTRUCTION AND DISTURBANCE AREAS. SEE SPECS.
- SEE DWG D-01 FOR TYPICAL TRENCH SECTIONS.
- EFFLUENT PIPE 48" I.D. CEMENT MORTAR LINED AND COATED STEEL OR 48" O.D. HDPE UNLESS SHOWN OTHERWISE.



KEYNOTES (⬡)

- SEE DWG D-05 FOR CONTRACTOR STAGING AND ACCESS DETAILS.
- APPROXIMATE LOCATION CORRESPONDING TO LOCATION OF TAX LOT OR PROPERTY LINE IN PLAN. FIELD VERIFY PROPERTY BOUNDARY FROM SURVEY.
- PROVIDE AIR VALVE. SEE DET 1 ON DWG D-03. PLACE AT HIGH POINT IN PIPE, FIELD VERIFY.
- OHWM LINE, APPROXIMATE FROM SURVEY SHOTS.
- CONCRETE REVETMENT MAT. SEE DET 3 ON DWG D-04.
- REMOVE EXISTING OUTFALL PIPE DIFFUSERS, SUPPORTING PILES, AND RIP RAP OVERLAYING AND PROTECTING PIPE. PROVIDE GRANULAR IMPORT FILL MATERIAL TO FILL VOID AND RESTORE SURFACE TO ELEVATION BEFORE REMOVAL OR MATCH SURROUNDING GRADES. PRESERVE AND PROTECT EXISTING PILE DIKE ADJACENT WALL.
- PROVIDE NAVIGATION MARKER. SEE DETAIL 1 ON D-08.
- PROVIDE SIGN ON NAVIGATION MARKER WITH WARNING TO AVOID SUBSURFACE OUTFALL DIFFUSER, COMPLIANT WITH COAST GUARD REGULATIONS AND PERMIT REQUIREMENTS. SEE SPECS.
- DIFFERENCE IN GRADE RESULTING FROM LIMITS OF SURVEY FROM 2017 AND 2015 LAND SURVEYS.

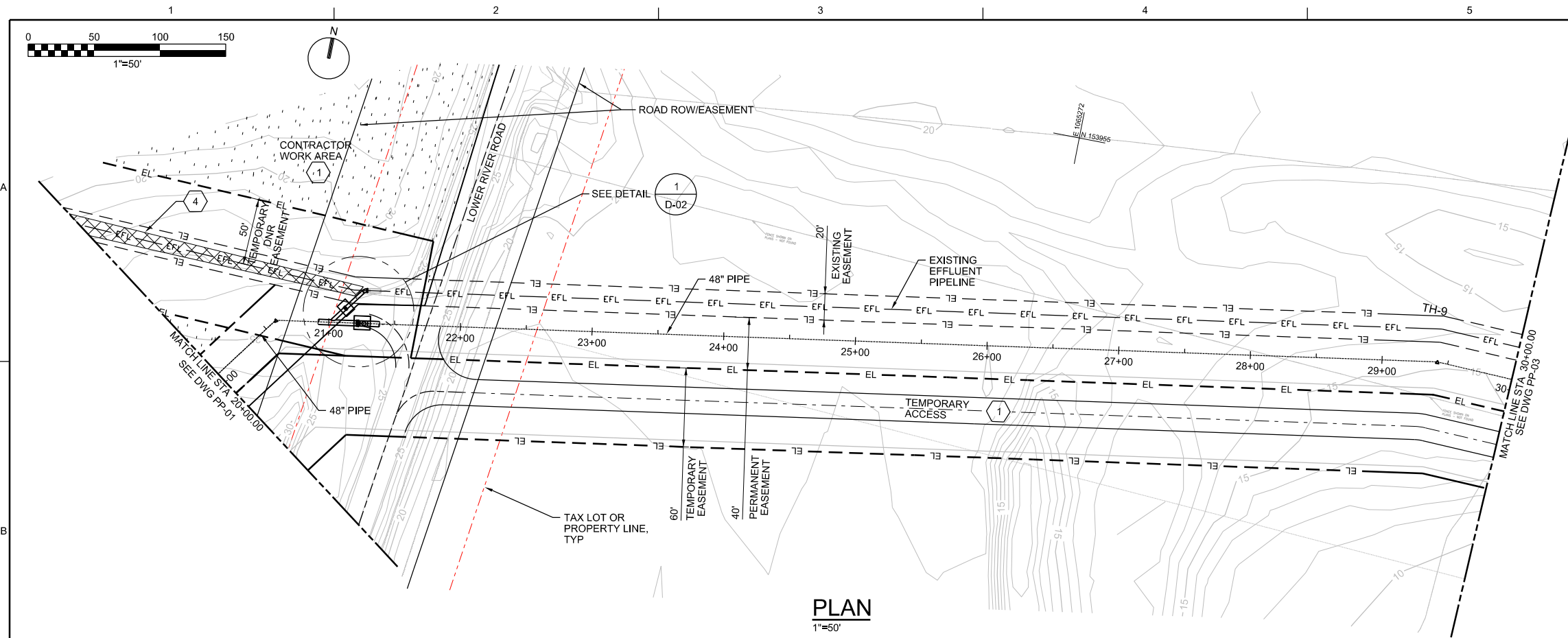
NO.	DATE	DR	REVISION	CHK	APVD	BY	APVD

Project 92-2016-0023
Columbia River Outfall and Effluent Pipeline Project
Discovery Clean Water Alliance
Clark County, Washington

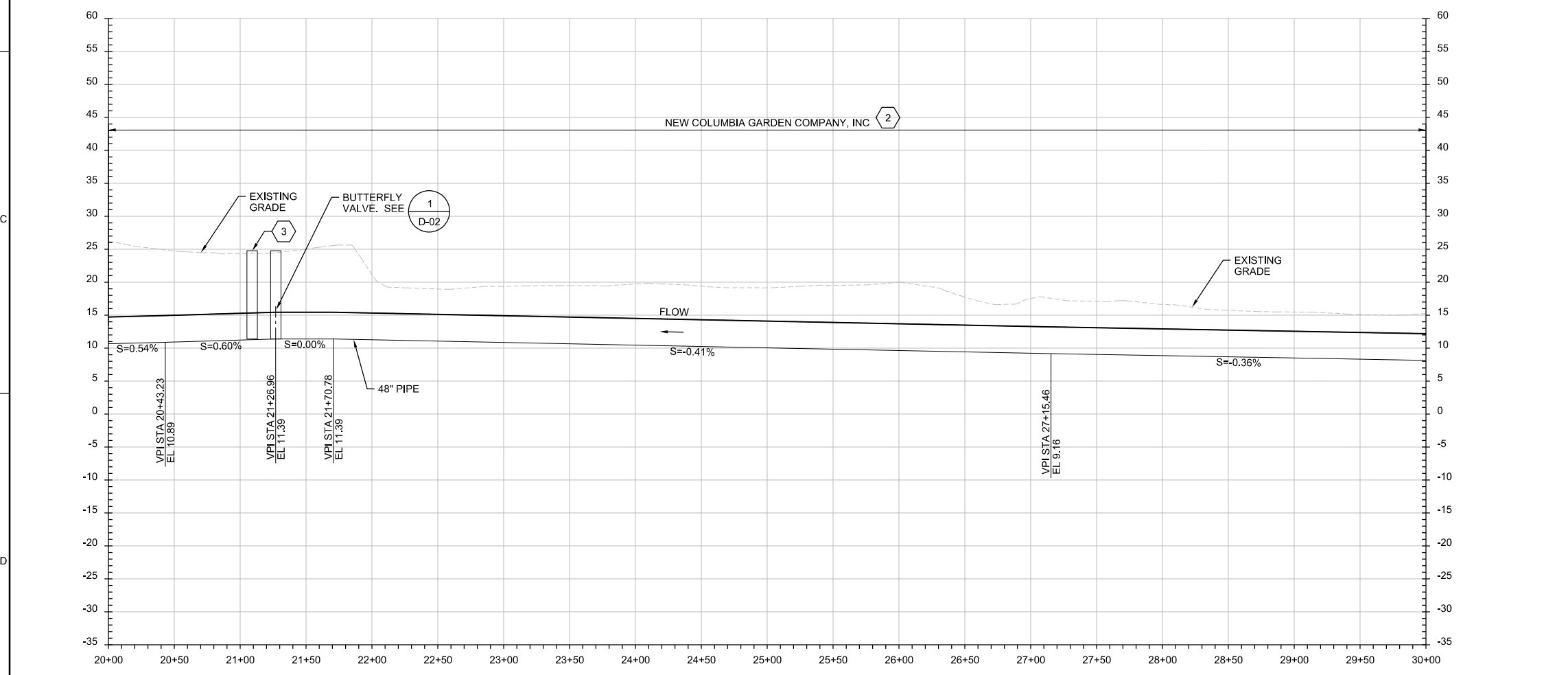
ch2m
PLAN & PROFILE
EFFLUENT PIPELINE
STA 10+00 TO 20+00

DATE	FEBRUARY 2018
PROJ	663264
DWG	PP-01
SHEET	6 of 26

30% DESIGN SUBMITTAL



PLAN
1"=50'



PROFILE
1"=50' HORIZ, 1"=10' VERT

GENERAL NOTES

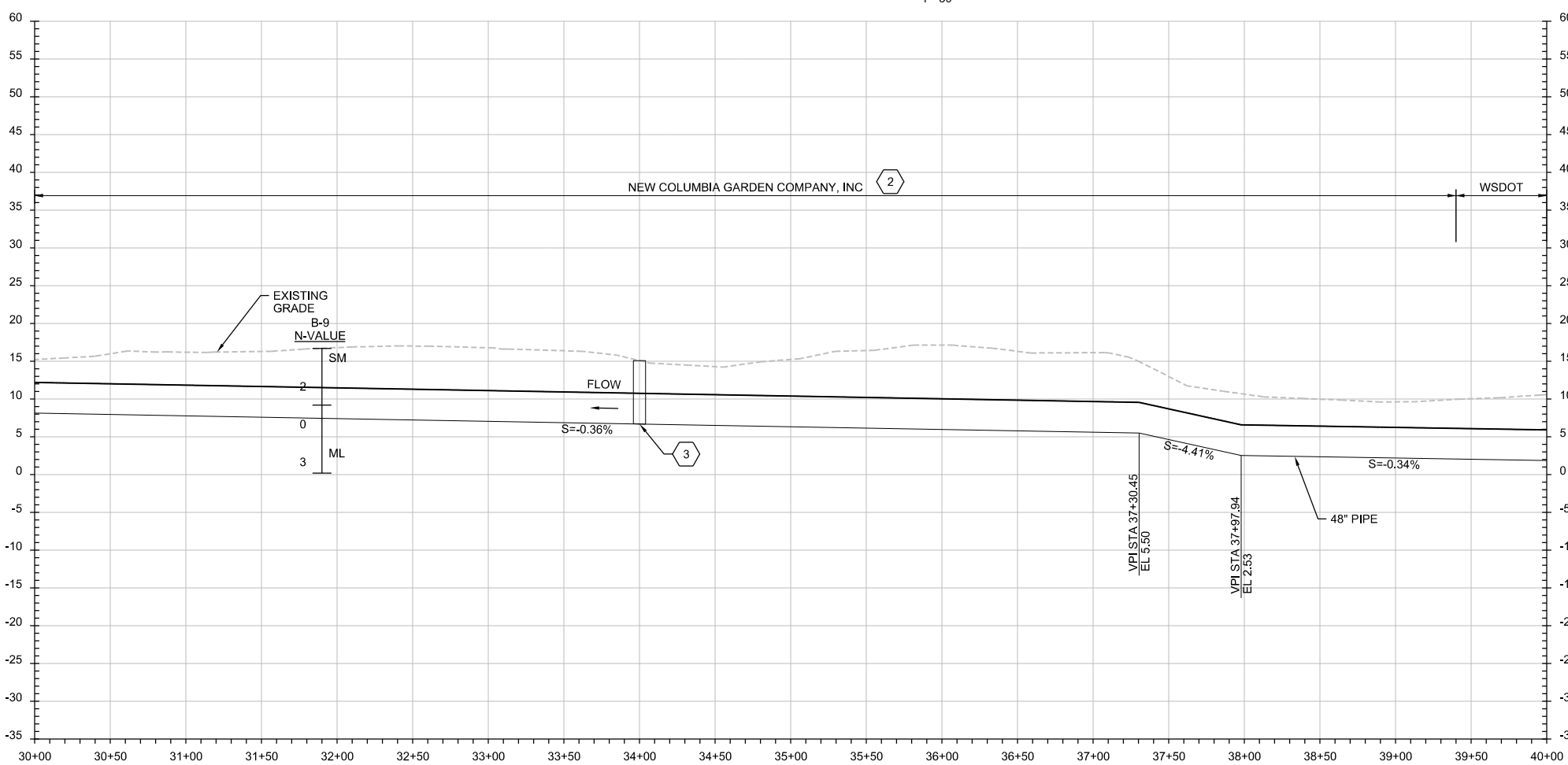
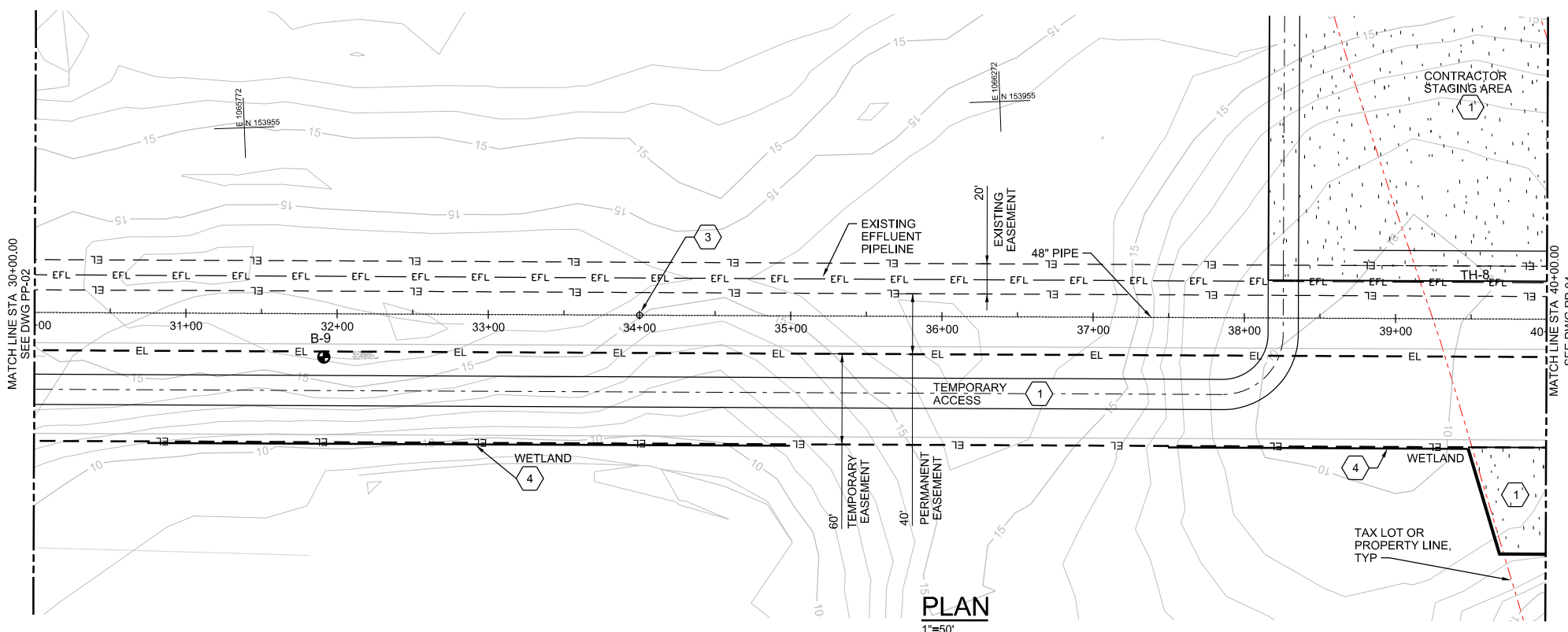
- SEE GENERAL NOTES ON PP-01.

KEYNOTES (⬡)

- SEE DWG D-05 FOR CONTRACTOR STAGING AND ACCESS DETAILS.
- LAND OWNERSHIP, TYP. FIELD VERIFY LOCATION OF TAX LOT OR PROPERTY LINE IN PLAN. FIELD VERIFY PROPERTY BOUNDARY FROM SURVEY.
- PROVIDE AIR VALVE. SEE DET 1 ON DWG D-03. PLACE AT HIGH POINT IN PIPE. FIELD VERIFY CONNECTION TO EXISTING OUTFALL, SEE DET 1 ON DWG D-02.
- REMOVE EXISTING OUTFALL PIPE, SUPPORTING PILES, AND RIP RAP OVERLAYING AND PROTECTING PIPE. PROVIDE GRANULAR IMPORT FILL MATERIAL TO FILL VOID AND RESTORE SURFACE TO ELEVATION BEFORE REMOVAL.

		PLAN & PROFILE EFFLUENT PIPELINE STA 20+00 TO 30+00	
Project 92-2016-0023 Columbia River Outfall and Effluent Pipeline Project Discovery Clean Water Alliance Clark County, Washington		DSGN NO. DATE DR B. THOMPSON CHK D. SUNSERI REVISION Q. COTTEN BY APVD R. BEIELER	
VERIFY SCALE BAR IS ONE INCH ON ORIGINAL DRAWING.		DATE FEBRUARY 2018 PROJ 663264 DWG PP-02 SHEET 7 of 26	

30% DESIGN SUBMITTAL

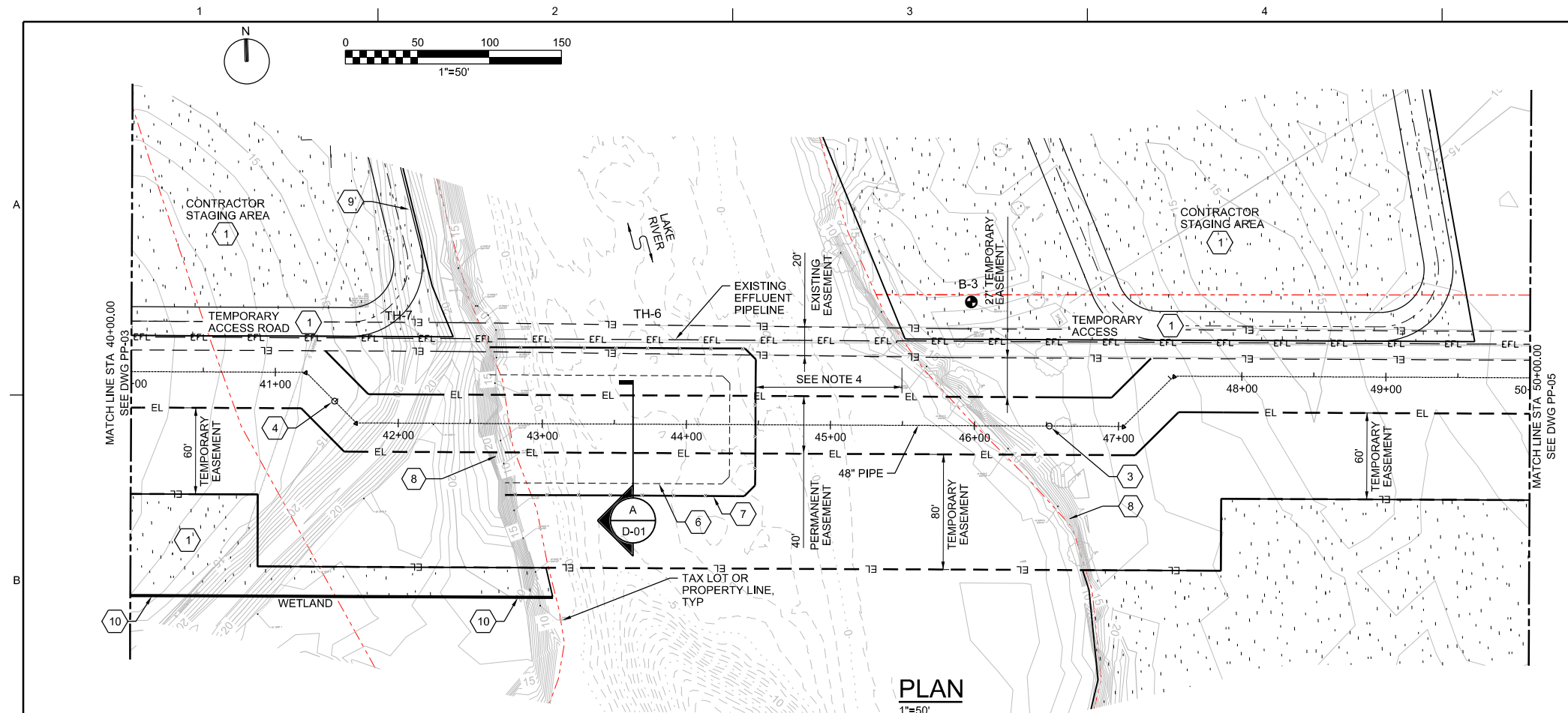


GENERAL NOTES

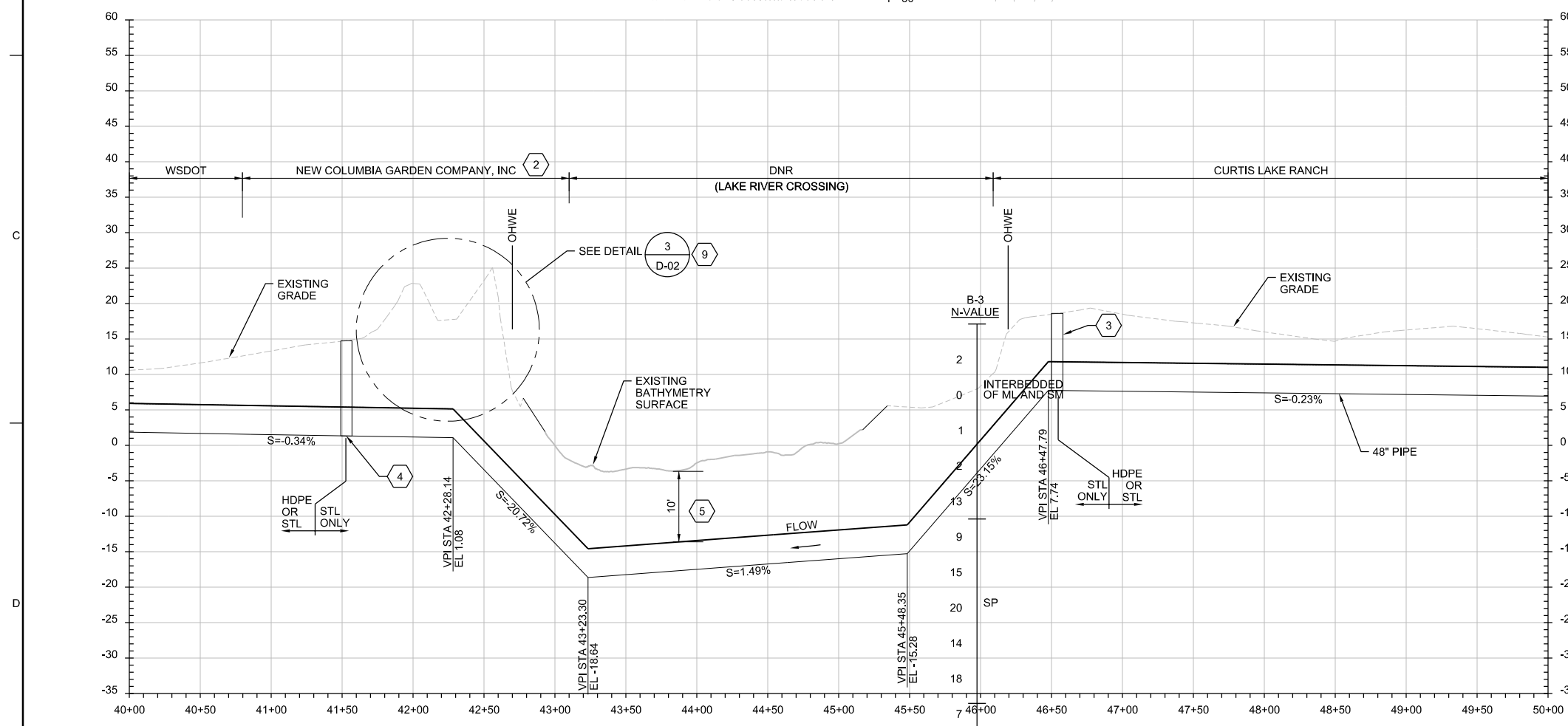
- SEE GENERAL NOTES ON PP-01.

KEYNOTES (⬡)

- SEE DWG D-05 FOR CONTRACTOR STAGING AND ACCESS DETAILS.
- LAND OWNERSHIP, TYP. APPROXIMATE LOCATION CORRESPONDING TO LOCATION OF TAX LOT OR PROPERTY LINE IN PLAN. FIELD VERIFY PROPERTY BOUNDARY FROM SURVEY.
- PROVIDE ACCESS MANHOLE. SEE DET 2 ON DWG D-03.
- INSTALL HI-VIZ FENCING.



PLAN
1"=50'



PROFILE
1"=50' HORIZ, 1"=10' VERT

GENERAL NOTES

- SEE GENERAL NOTES ON PP-01.
- NO PILE OR SHEET PILE INSTALLATION OR EXCAVATION OF ANY KIND ALLOWED WITHIN 20 FEET OF EXTERNAL OUTFALL PIPE.
- FACILITIES SHOWN IDENTIFY A CONSTRUCTION METHOD FOR PIPELINE INSTALLATION FOR HALF OF THE RIVER AT A TIME. CONTRACTOR SHALL DETERMINE MEANS AND METHODS FOR CONSTRUCTING NEW OUTFALL PIPELINE IN ACCORDANCE WITH AGENCY PERMIT REQUIREMENTS AND AS APPROVED BY OWNER. SEE DWG D-10 FOR POSSIBLE SEQUENCE.
- CONTRACTOR TO MAINTAIN A MINIMUM OF 70 FT. OF OPEN WATER TO ALLOW FOR BOAT TRAFFIC ON RIVER.

KEYNOTES (⬡)

- SEE DWG D-05 FOR CONTRACTOR STAGING AND ACCESS DETAILS.
- LAND OWNERSHIP, TYP. APPROXIMATE LOCATION CORRESPONDING TO LOCATION OF TAX LOT OR PROPERTY LINE IN PLAN. FIELD VERIFY PROPERTY BOUNDARY FROM SURVEY.
- PROVIDE AIR VALVE. SEE DET 1 ON DWG D-03.
- PROVIDE ACCESS MANHOLE. SEE DET 2 ON DWG D-03.
- MIN COVER DEPTH. FIELD VERIFY ELEVATION OF EXST RIVER BOTTOM BEFORE CONSTRUCTION AND FIELD ADJUST PROFILE TO MAINTAIN MINIMUM DEPTH. SEE GENERAL NOTES.
- CONTRACTOR DESIGNED DIVERSION DAM FOR PIPELINE INSTALLATION ACROSS HALF THE RIVER AT A TIME. SEE NOTE 3.
- PROVIDE SEDIMENT CURTAIN. SEE SPECS.
- OHW LINE, APPROXIMATELY 13.1'.
- REBUILD DIKE/ DITCH IN AREA DISTURBED BY CONSTRUCTION. SURVEY BERMS BEFORE CONSTRUCTION AND RECONSTRUCT WITH SAME ELEVATIONS.
- INSTALL HI-VIZ FENCING.

NO.	DATE	DR	REVISION	CHK	BY	APVD
		B. THOMPSON				R. BEIELER
		D. SUNSERI				Q. COTTEN

Project 92-2016-0023
Columbia River Outfall and Effluent Pipeline Project
Discovery Clean Water Alliance
Clark County, Washington

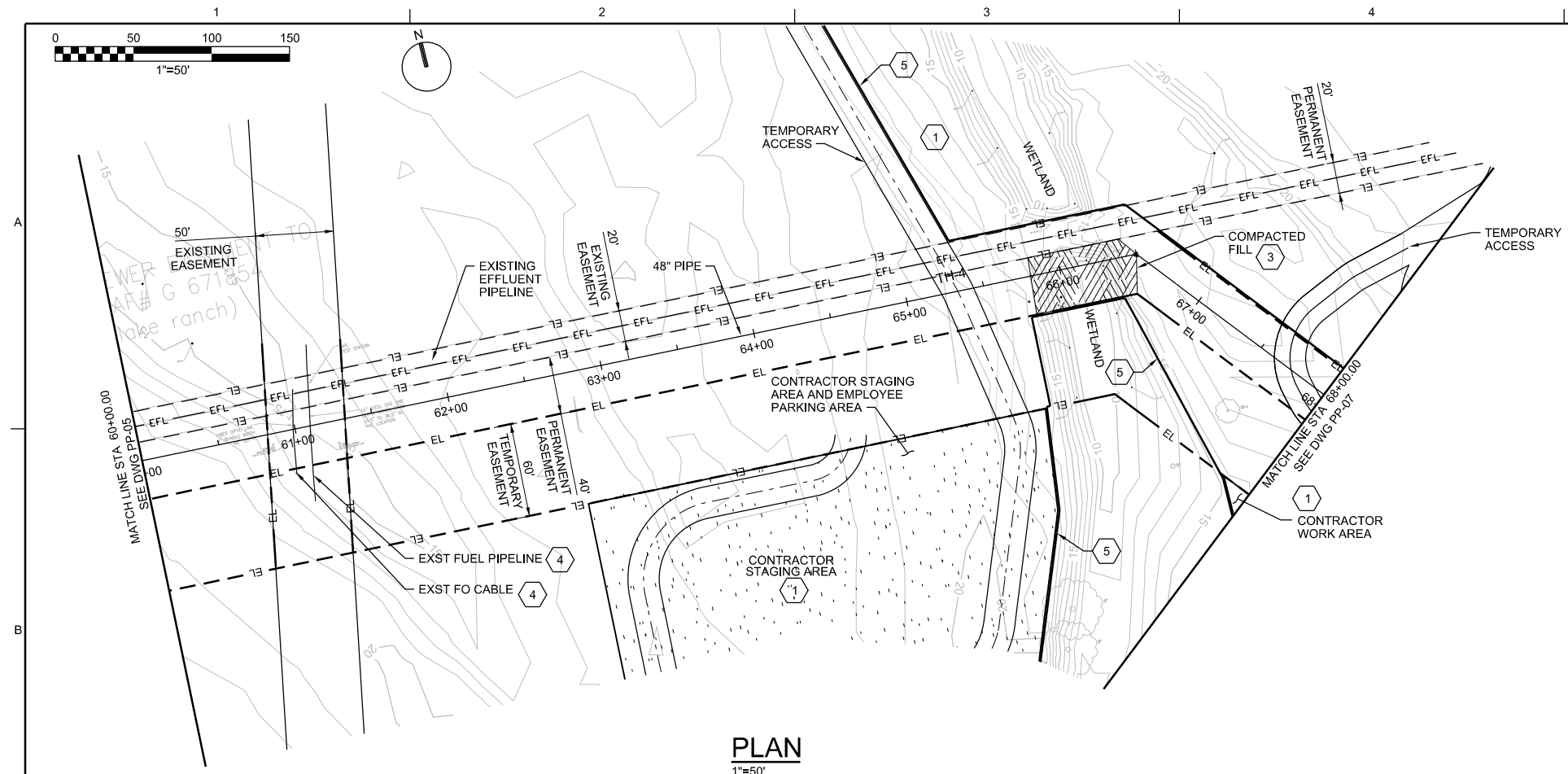
ch2m
PLAN & PROFILE
EFFLUENT PIPELINE
STA 40+00 TO 50+00

VERIFY SCALE	
BAR IS ONE INCH ON ORIGINAL DRAWING.	
DATE	FEBRUARY 2018
PROJ	663264
DWG	PP-04
SHEET	9 of 26

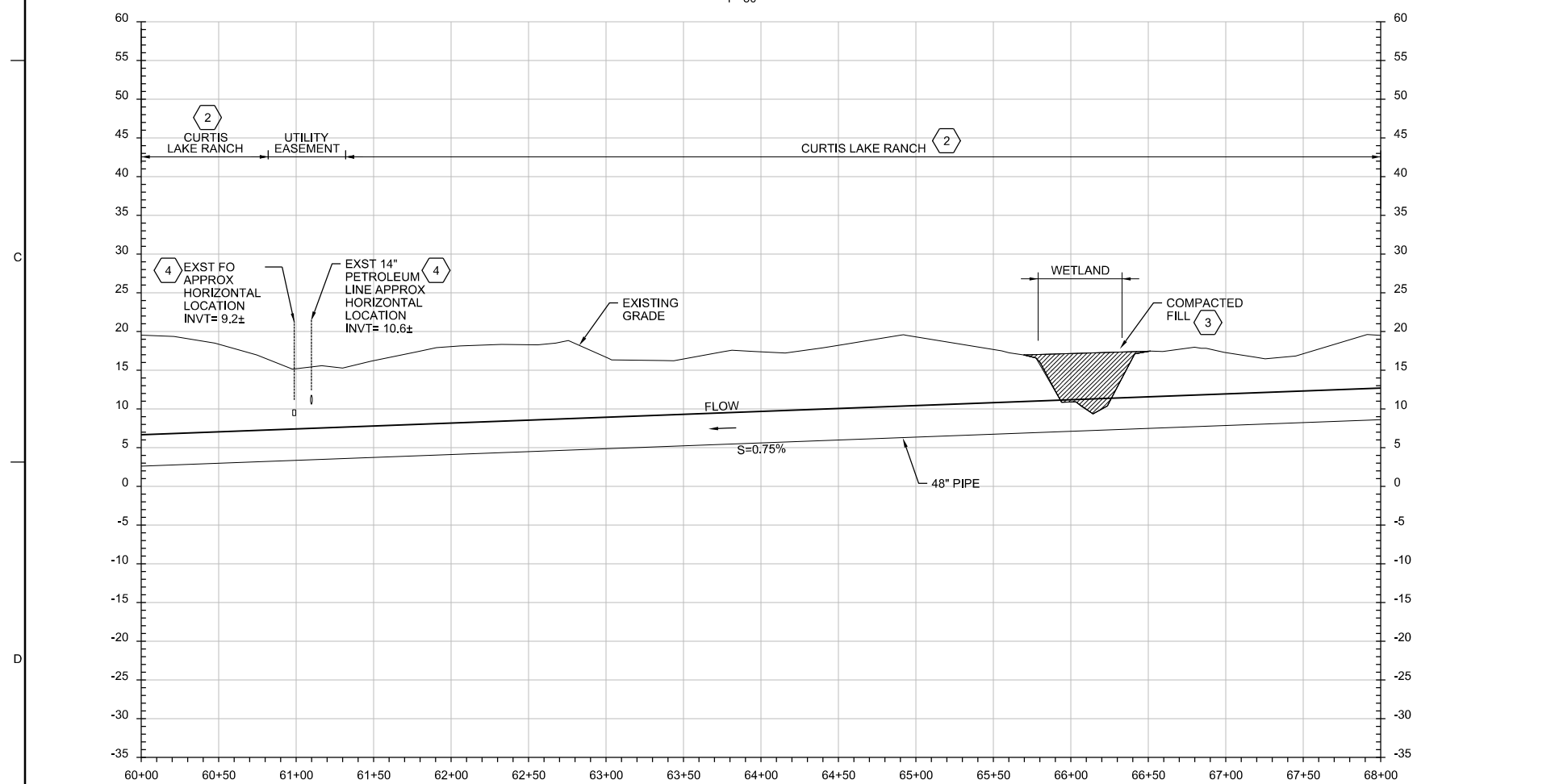
30% DESIGN SUBMITTAL

© CH2M HILL 2018. ALL RIGHTS RESERVED.

THIS DOCUMENT, AND THE IDEAS AND DESIGNS INCORPORATED HEREIN, AS AN INSTRUMENT OF PROFESSIONAL SERVICE, IS THE PROPERTY OF CH2M HILL AND IS NOT TO BE USED, IN WHOLE OR IN PART, FOR ANY OTHER PROJECT WITHOUT THE WRITTEN AUTHORIZATION OF CH2M HILL.



PLAN
1"=50'



PROFILE
1"=50' HORIZ, 1"=10' VERT

GENERAL NOTES

- 1. SEE GENERAL NOTES ON PP-01.

KEYNOTES (⬡)

- 1. SEE DWG D-05 FOR CONTRACTOR STAGING AND ACCESS DETAILS.
- 2. LAND OWNERSHIP, TYP. APPROXIMATE LOCATION CORRESPONDING TO LOCATION OF TAX LOT OR PROPERTY LINE IN PLAN. FIELD VERIFY PROPERTY BOUNDARY FROM SURVEY.
- 3. PLACE AND COMPACT IMPORT FILL MATERIAL WITHIN EASEMENT LIMITS. PLACE AND COMPACT 6" CRUSHED SURFACING ON FILL AND GRADE TO MATCH EXISTING.
- 4. NOTIFY UTILITY PURVEYORS 3 WEEKS BEFORE CONSTRUCTION NEAR THEIR UTILITIES. PRESERVE AND PROTECT FO AND FUEL LINES DURING CONSTRUCTION. PROVIDE TEMPORARY SUPPORT DURING CONSTRUCTION AND REPAIR ANY DAMAGE TO LINES AS REQUIRED BY UTILITY PURVEYORS.
- 5. INSTALL HI-VIZ FENCING.

NO.	DATE	DR	CHK	APVD	BY	APVD
		B. THOMPSON	D. SUNSERI	Q. COTTEN	R. BEIELER	

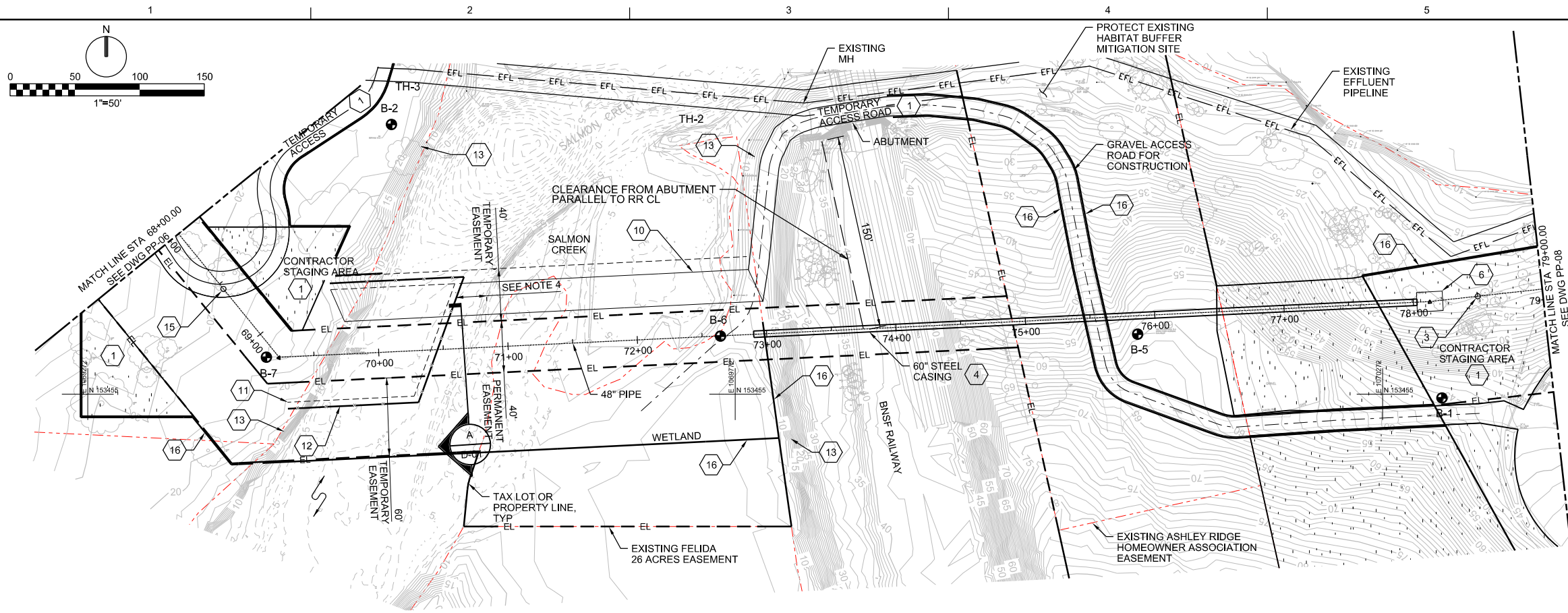
Project 92-2016-0023
Columbia River Outfall and Effluent Pipeline Project
Discovery Clean Water Alliance
Clark County, Washington

ch2m
PLAN & PROFILE
EFFLUENT PIPELINE
STA 60+00 TO 68+00

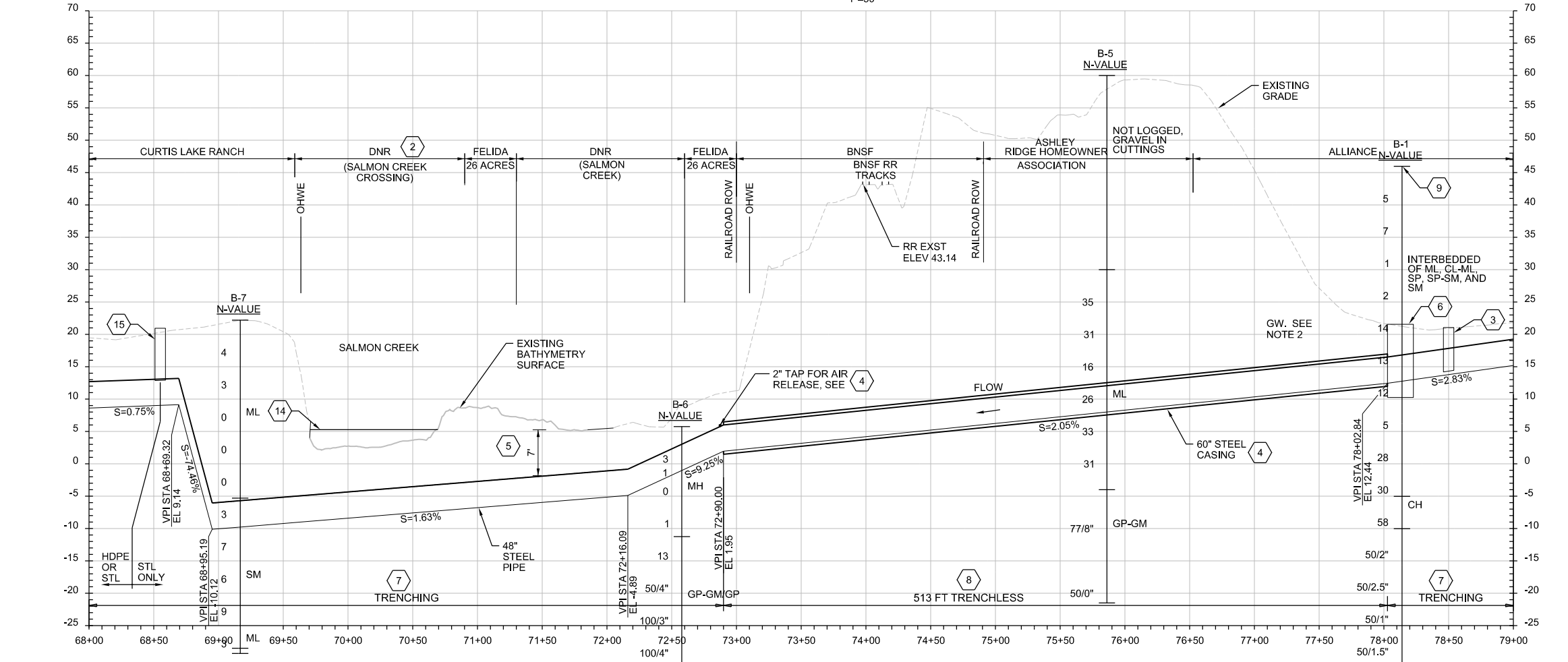
VERIFY SCALE	
BAR IS ONE INCH ON ORIGINAL DRAWING.	
DATE	FEBRUARY 2018
PROJ	663264
DWG	PP-06
SHEET	11 of 26

30% DESIGN SUBMITTAL

© CH2M HILL 2018. ALL RIGHTS RESERVED.



PLAN
1"=50'



PROFILE
1"=50' HORIZ, 1"=10' VERT

GENERAL NOTES

- SEE GENERAL NOTES ON PP-01.
- GROUND WATER ELEVATION VARIES ALONG ALIGNMENT WITH SEASON AND RIVER STAGE.
- FACILITIES SHOWN IDENTIFY A CONSTRUCTION METHOD FOR PIPELINE INSTALLATION FOR HALF OF THE RIVER AT A TIME. CONTRACTOR SHALL DETERMINE MEANS AND METHODS FOR CONSTRUCTING NEW OUTFALL PIPELINE IN ACCORDANCE WITH AGENCY PERMIT REQUIREMENTS AND AS APPROVED BY OWNER. SEE DWG D-09 FOR POSSIBLE SEQUENCE.
- CONTRACTOR TO MAINTAIN A MINIMUM OF 20 FT OF OPEN WATER OR PROVIDE PORTAGE SUPPORT FOR PERSONAL WATERCRAFTS.

KEYNOTES (○)

- SEE DWG D-05 FOR CONTRACTOR STAGING AND ACCESS DETAILS.
- LAND OWNERSHIP, TYP. APPROXIMATE LOCATION CORRESPONDING TO LOCATION OF TAX LOT OR PROPERTY LINE IN PLAN. FIELD VERIFY PROPERTY BOUNDARY FROM SURVEY.
- PROVIDE AIR VALVE. SEE DET 4 ON DWG D-03.
- SEE CASING DETAIL 3 & 4 ON D-03.
- MIN COVER DEPTH UNDER SALMON CREEK. FIELD VERIFY ELEVATION OF EXST CREEK BOTTOM BEFORE CONSTRUCTION AND FIELD ADJUST PROFILE TO MAINTAIN MINIMUM DEPTH. SEE GENERAL NOTES.
- TRENCHLESS LAUNCH PIT. SIZE AS REQUIRED FOR TRENCHLESS OPERATIONS.
- TRENCHING METHOD DETERMINED BY CONTRACTOR. SEE SPECS.
- TRENCHLESS METHOD DETERMINED BY CONTRACTOR. SEE SPECS.
- SOIL BORING LOG INFORMATION AVAILABLE IN GEOTECHNICAL DATA REPORT.
- CONTRACTOR DESIGNED TEMPORARY WORK TRESTLE.
- CONTRACTOR DESIGNED DIVERSION DAM FOR PIPELINE INSTALLATION ACROSS HALF RIVER AT A TIME. SEE GENERAL NOTE 3.
- PROVIDE SEDIMENT CURTAIN. SEE SPECS.
- OHWM LINE, APPROXIMATELY 13.1'
- WATER SURFACE ELEVATION FROM SURVEY, OCTOBER 2017, ELEVATION VARIES WIDELY DURING YEAR.
- PROVIDE AIR VALVE, SEE DETAIL 1 ON D-03.
- INSTALL HI-VIZ FENCING.

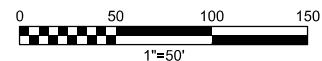
NO.	DATE	DR	REVISION	BY	APVD

Project 92-2016-0023
Columbia River Outfall and Effluent Pipeline Project
Discovery Clean Water Alliance
Clark County, Washington

ch2m
PLAN & PROFILE
EFFLUENT PIPELINE
STA 68+00 TO 79+00

DATE	FEBRUARY 2018
PROJ	663264
DWG	PP-07
SHEET	12 of 26

30% DESIGN SUBMITTAL



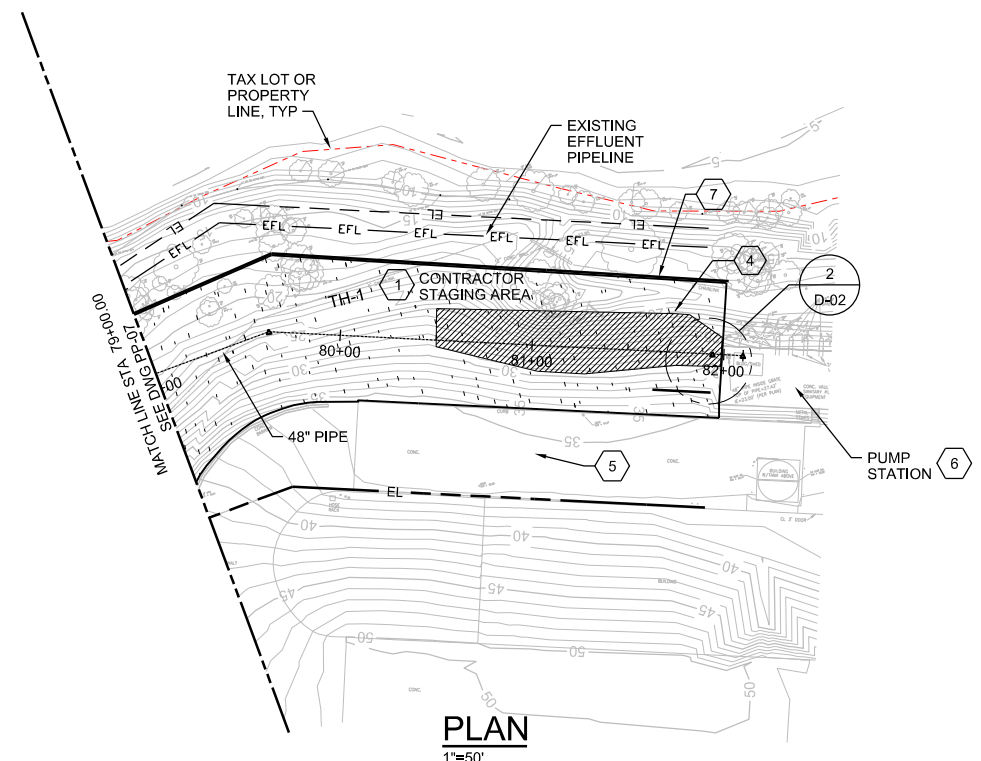
GENERAL NOTES

- SEE GENERAL NOTES ON PP-01.

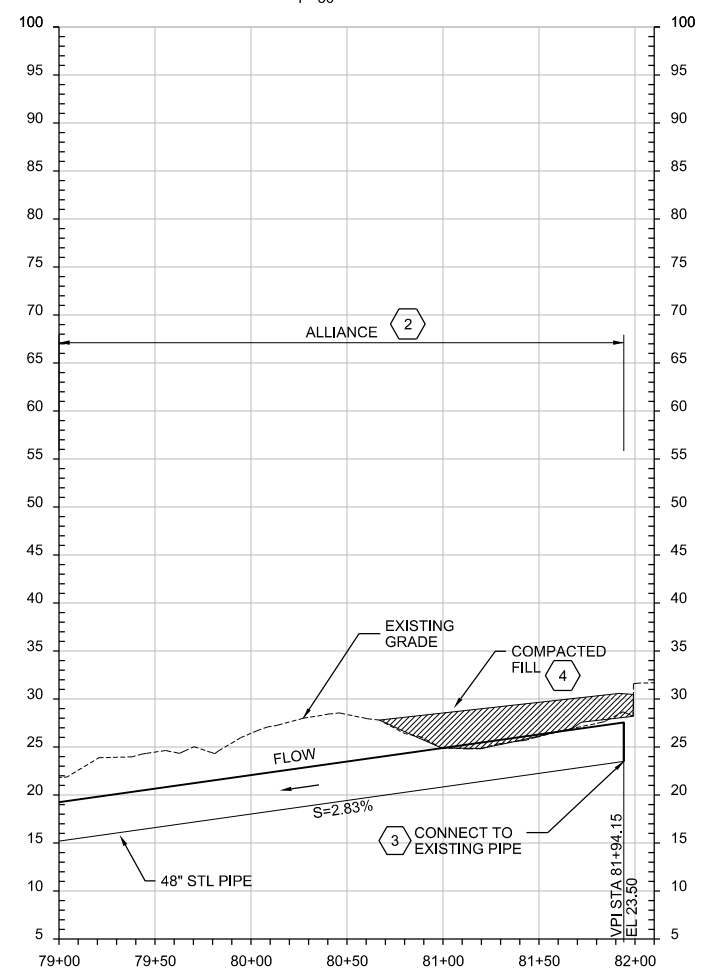
KEYNOTES (⬡)

- SEE DWG D-05 FOR CONTRACTOR STAGING AND ACCESS DETAILS.
- LAND OWNERSHIP, TYP. APPROXIMATE LOCATION CORRESPONDING TO LOCATION OF TAX LOT OR PROPERTY LINE IN PLAN. FIELD VERIFY PROPERTY BOUNDARY FROM SURVEY.
- CONNECT TO EXISTING PUMP STATION PIPING, NOT SHOWN. SEE DET 2 ON DWG D-02.
- PLACE AND COMPACT IMPORT FILL MATERIAL. PLACE 6" TOPSOIL TO MATCH EXISTING.
- EXISTING ROADWAY ACCESS TO REMAIN OPEN AND ACCESSIBLE FOR OWNER OPERATIONS AT ALL TIMES. COORDINATE ALL ACTIVITIES WITH OWNER.
- SEE PS-01 FOR PUMP STATION MODIFICATIONS.
- INSTALL HI-VIZ FENCING.

A
B
C
D



PLAN
1"=50'



PROFILE
1"=50' HORIZ, 1"=10' VERT

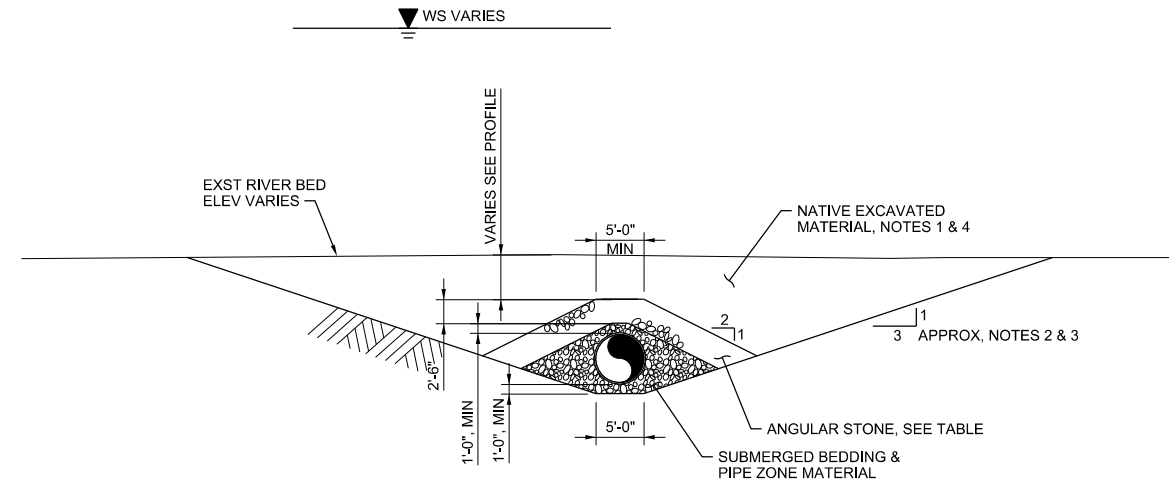
Project 92-2016-0023
Columbia River Outfall and Effluent Pipeline Project
Discovery Clean Water Alliance
Clerk County, Washington

ch2m
PLAN & PROFILE
EFFLUENT PIPELINE
STA 79+00 TO 81+66

VERIFY SCALE	
BAR IS ONE INCH ON ORIGINAL DRAWING.	
DATE	FEBRUARY 2018
PROJ	663264
DWG	PP-08
SHEET	13 of 26

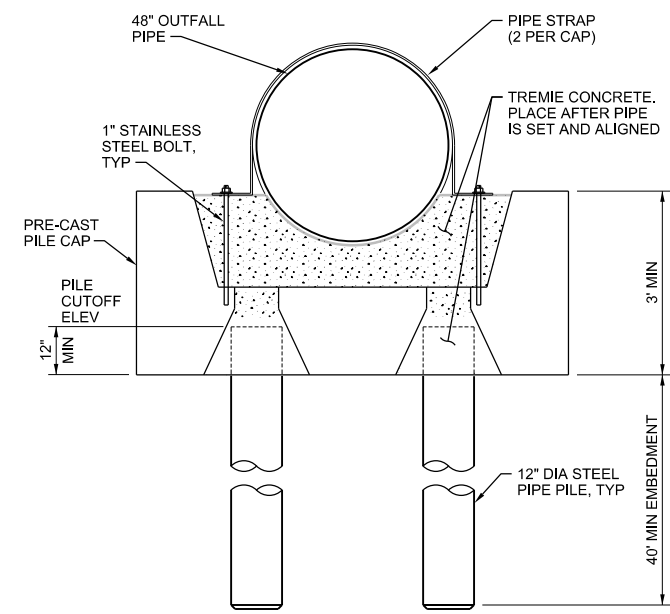
30% DESIGN SUBMITTAL

RE/USE OF DOCUMENTS: THIS DOCUMENT, AND THE IDEAS AND DESIGNS INCORPORATED HEREIN, AS AN INSTRUMENT OF PROFESSIONAL SERVICE, IS THE PROPERTY OF CH2M HILL AND IS NOT TO BE USED, IN WHOLE OR IN PART, FOR ANY OTHER PROJECT WITHOUT THE WRITTEN AUTHORIZATION OF CH2M HILL.
D. WILSON DR
D. SUNSERI CHK
Q. COTTEN APVD
R. BEIELER BY APVD
©CH2M HILL 2018. ALL RIGHTS RESERVED.

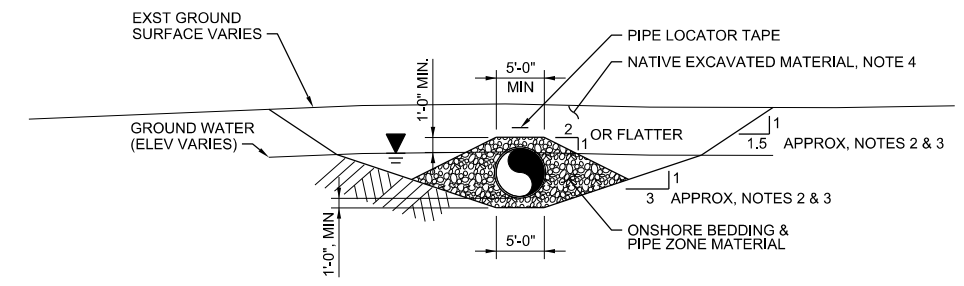


WATERBODY	STONE SIZE
SALMON CREEK	6'-0 STONE
LAKE RIVER	4'-0 STONE
COLUMBIA RIVER	CLASS 50 RIPRAP

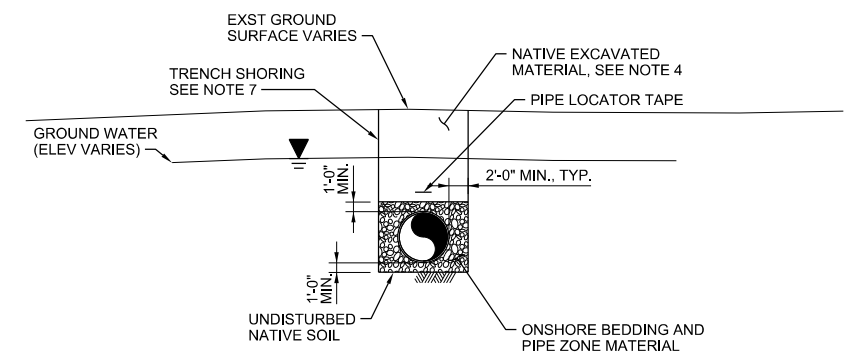
A IN-WATER TRENCH TYPICAL SECTION
PP-01
D-07



1 PILE CAP DETAIL
NTS
D-06



B ONSHORE UNSHORED TRENCH SECTION
NTS
PP-0X



C ONSHORE SHORED TYPICAL TRENCH SECTION
NTS
PP-0X

NOTE:
USE TO AVOID WETLANDS AND OTHER SENSITIVE AREAS
AND TO STAY WITHIN EASEMENT LIMITS AS NECESSARY.

- NOTES:
- BACKFILL ABOVE ANGULAR ROCK WITH GRANULAR FILL TO EXISTING RIVER BED ELEVATION, UNLESS OTHERWISE SHOWN.
 - INDICATED SLOPES ARE APPROXIMATIONS OF ANTICIPATED NATURAL, UNSHORED, LAYBACK BASED ON LIMITED GEOTECHNICAL INVESTIGATION. CONTRACTOR SHALL BE PREPARED FOR NATURAL LAYBACK OTHER THAN WHAT IS SHOWN.
 - CONTRACTOR SHALL SLOPE OR SHORE TRENCH IN CONFORMANCE WITH ALL LOCAL, STATE, AND FEDERAL STANDARDS FOR SAFETY AND ENVIRONMENTAL PERMITS.
 - CONTRACTOR SHALL REMOVE AND DISPOSE OF EXCESS NATIVE EXCAVATED MATERIAL FROM WATERWAY AND ALL DEBRIS, TRASH, OR RUBBLE ENCOUNTERED IN EXCAVATED MATERIAL.
 - HEAVY CONSTRUCTION EQUIPMENT SHALL NOT TRAVERSE THE PIPE UNLESS ADEQUATE PROTECTION APPROVED BY ENGINEER IS INSTALLED SUCH AS STEEL PLATES OR CLSM PIPE ENCASUREMENT.
 - DISPOSE OF EXCESS NATIVE MATERIAL NOT USED FOR BACKFILL OFFSITE.
 - CONTRACTOR SHALL SHORE TRENCH EXCAVATION WITHIN WETLAND AREAS. OUTSIDE WETLANDS, CONTRACTOR MAY UTILIZE SHORED OR UNSHORED EXCAVATIONS.
 - SEE GEOTECHNICAL REPORT AND BORING LOCATIONS FOR EXISTING SOILS INFORMATION. ADJUST CONSTRUCTION METHODS FOR ACTUAL SOIL CONDITIONS ENCOUNTERED.

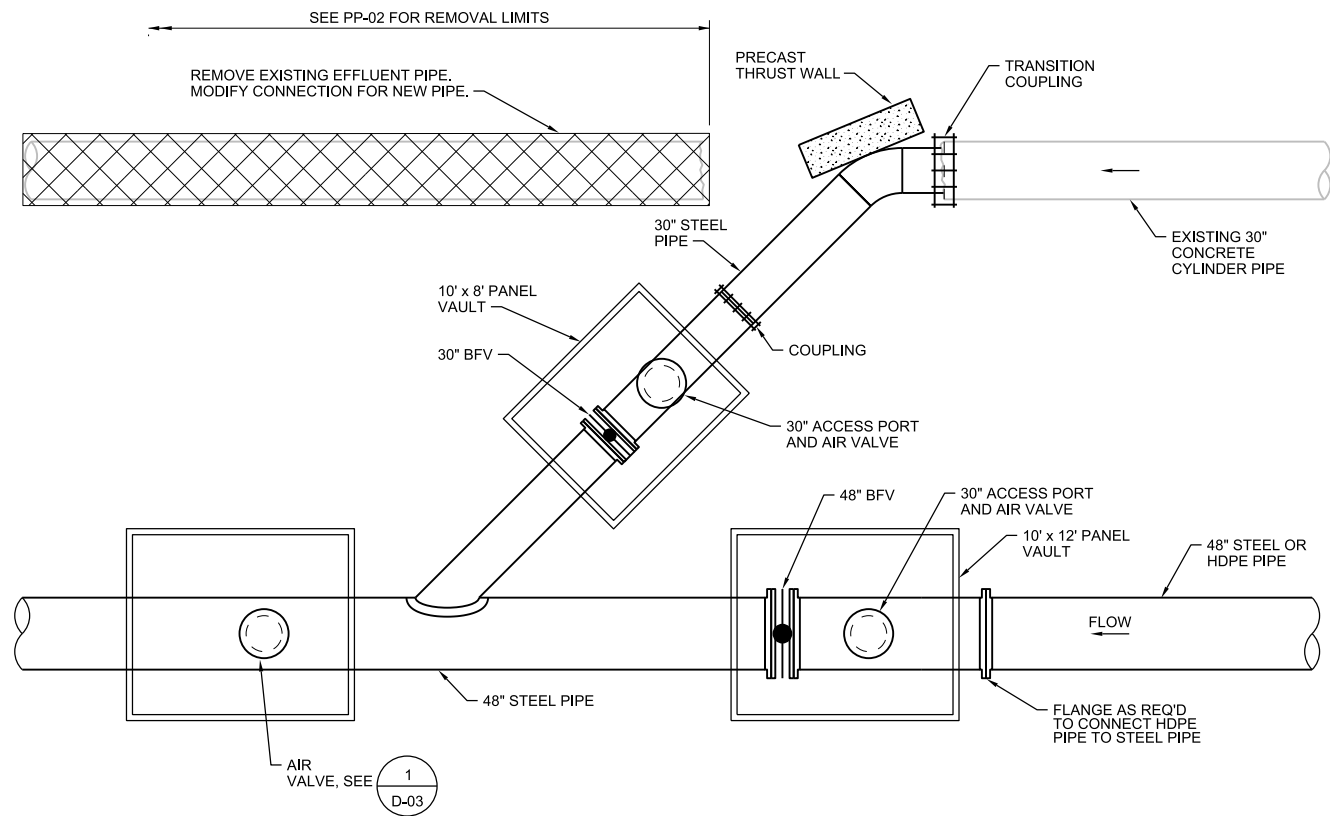
NO.	DATE	DR	CHK	REVISION	BY	APVD
		B. THOMPSON				
			D. SUNSERI			
			Q. COTTEN			
						R. BEIELER

Project 92-2016-0023
Columbia River Outfall and Effluent Pipeline Project
Discovery Clean Water Alliance
Clark County, Washington

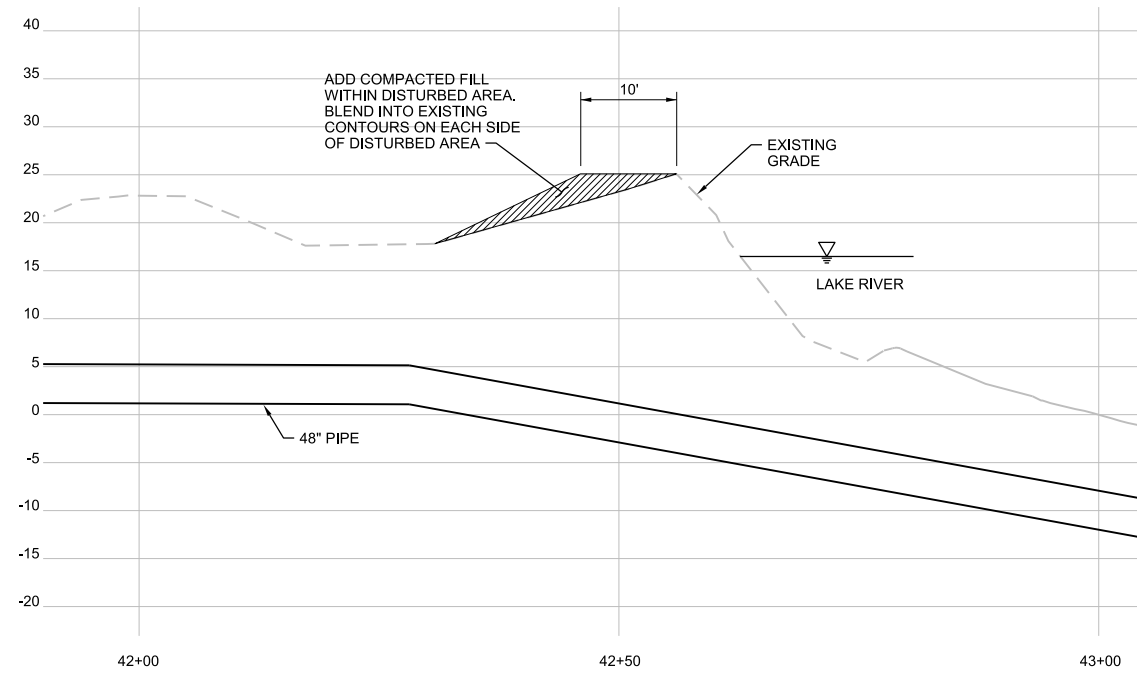
ch2m
DETAILS
OUTFALL AND TRENCH DETAILS

1" = X'
VERIFY SCALE
BAR IS ONE INCH ON ORIGINAL DRAWING.
DATE FEBRUARY 2018
PROJ 663264
DWG D-01
SHEET 14 of 26

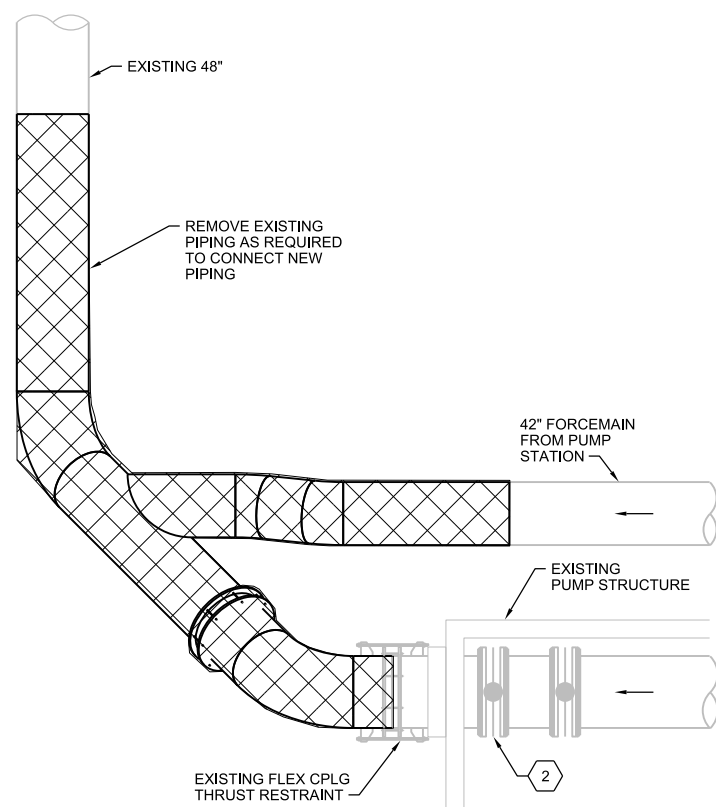
30% DESIGN SUBMITTAL



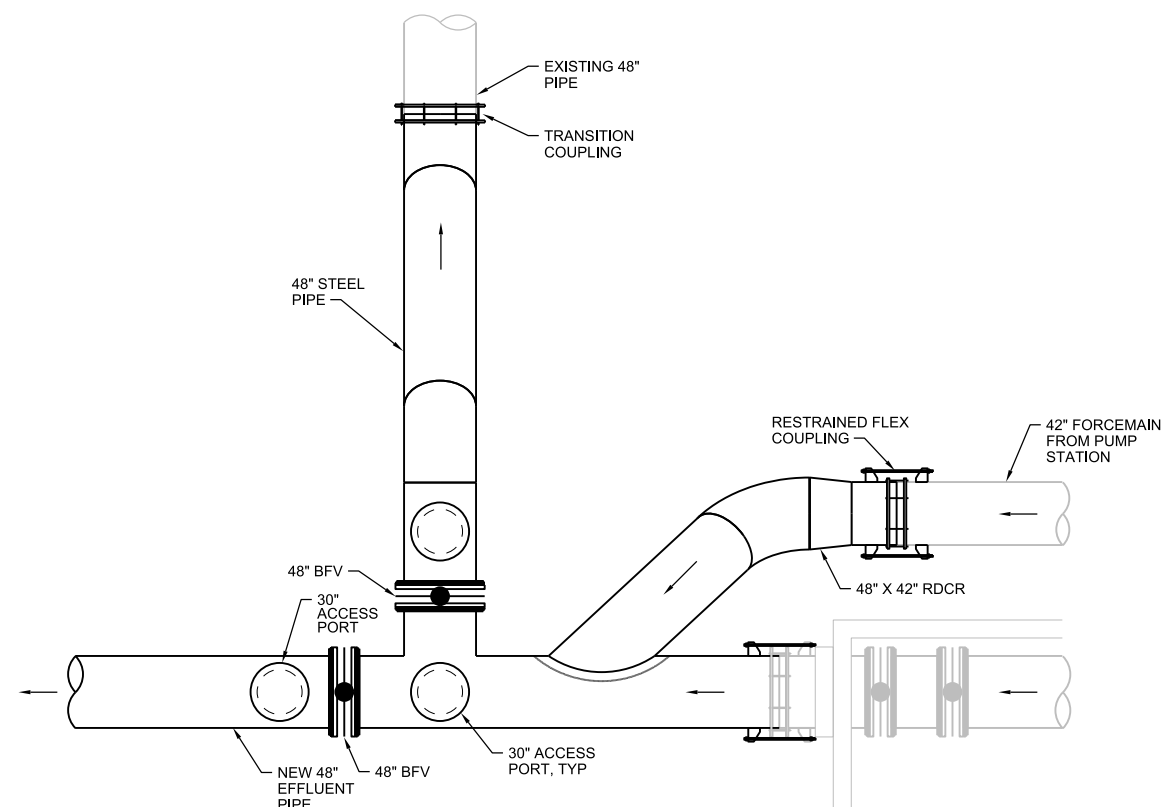
1 CONNECTION TO EXST OUTFALL PIPE
3/16"=1'-0"
PP-01



3 LAKE RIVER WEST BANK RECONSTRUCTION
1"=10"
PP-04



EXISTING CONFIGURATION



NEW CONFIGURATION

NOTES:
1. PRIOR TO REMOVING EXISTING PIPING, INSTALL LINE STOPS AND BYPASS SYSTEM. SEE DWG PS-01 FOR LOCATIONS.

2 CONNECTION TO EXST PUMP STATION PIPING
3/16"=1'-0"
PP-08

NO.	DATE	DR	CHK	APVD	BY	APVD
		J. KRUMSICK	D. SUNSERI	A. FINNEY	R. BEIELER	

Project 92-2016-0023
Columbia River Outfall and Effluent Pipeline Project
Discovery Clean Water Alliance
Clerk County, Washington

ch2m
DETAILS
CONNECTION AT PLANT AND OUTFALL CASING

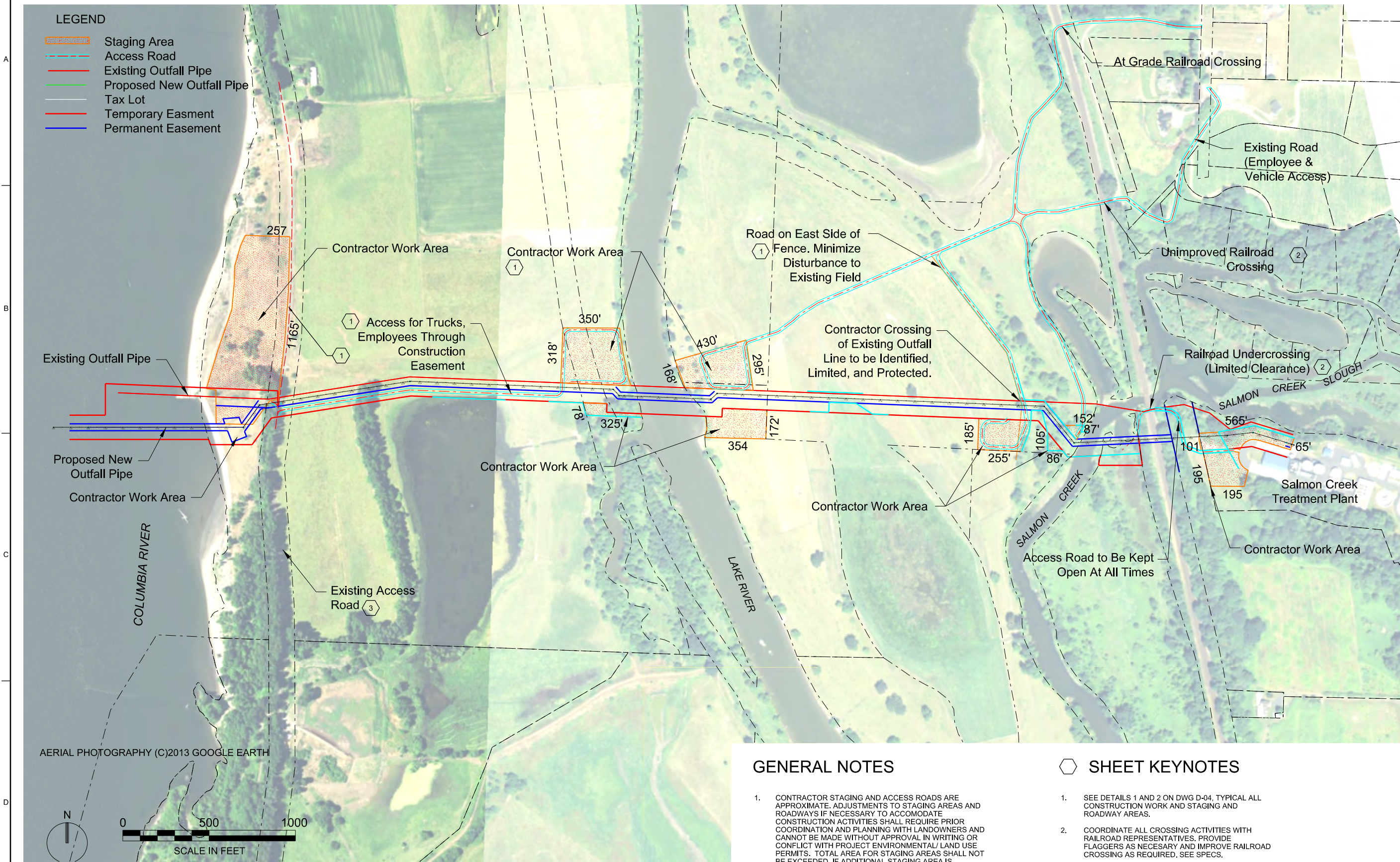
1" = X'	
VERIFY SCALE	
BAR IS ONE INCH ON ORIGINAL DRAWING.	
DATE	FEBRUARY 2018
PROJ	663264
DWG	D-02
SHEET	15 of 26

30% DESIGN SUBMITTAL

REUSE OF DOCUMENTS: THIS DOCUMENT, AND THE IDEAS AND DESIGNS INCORPORATED HEREIN, AS AN INSTRUMENT OF PROFESSIONAL SERVICE, IS THE PROPERTY OF CH2M HILL AND IS NOT TO BE USED, IN WHOLE OR IN PART, FOR ANY OTHER PROJECT WITHOUT THE WRITTEN AUTHORIZATION OF CH2M HILL. © CH2M HILL 2018. ALL RIGHTS RESERVED.

LEGEND

- Staging Area
- Access Road
- Existing Outfall Pipe
- Proposed New Outfall Pipe
- Tax Lot
- Temporary Easment
- Permanent Easment



AERIAL PHOTOGRAPHY (C)2013 GOOGLE EARTH



GENERAL NOTES

1. CONTRACTOR STAGING AND ACCESS ROADS ARE APPROXIMATE. ADJUSTMENTS TO STAGING AREAS AND ROADWAYS IF NECESSARY TO ACCOMMODATE CONSTRUCTION ACTIVITIES SHALL REQUIRE PRIOR COORDINATION AND PLANNING WITH LANDOWNERS AND CANNOT BE MADE WITHOUT APPROVAL IN WRITING OR CONFLICT WITH PROJECT ENVIRONMENTAL/ LAND USE PERMITS. TOTAL AREA FOR STAGING AREAS SHALL NOT BE EXCEEDED. IF ADDITIONAL STAGING AREA IS REQUIRED PROVIDE OFFSITE.
2. AERIAL IMAGE AND FEATURES SHOWN ARE SEVERAL YEARS OLD. FIELD VERIFY ACTUAL CONDITIONS AND ADJUST AS NECESSARY AND AS APPROVED BY ENGINEER.

SHEET KEYNOTES

1. SEE DETAILS 1 AND 2 ON DWG D-04, TYPICAL ALL CONSTRUCTION WORK AND STAGING AND ROADWAY AREAS.
2. COORDINATE ALL CROSSING ACTIVITIES WITH RAILROAD REPRESENTATIVES. PROVIDE FLAGGERS AS NECESSARY AND IMPROVE RAILROAD CROSSING AS REQUIRED. SEE SPECS.
3. FORMER COUNTY ROAD CURRENTLY OWNED BY LANDOWNER. REPAIR ASPHALT TO RE-EXISTING OR BETTER CONDITIONS AFTER CONSTRUCTION.

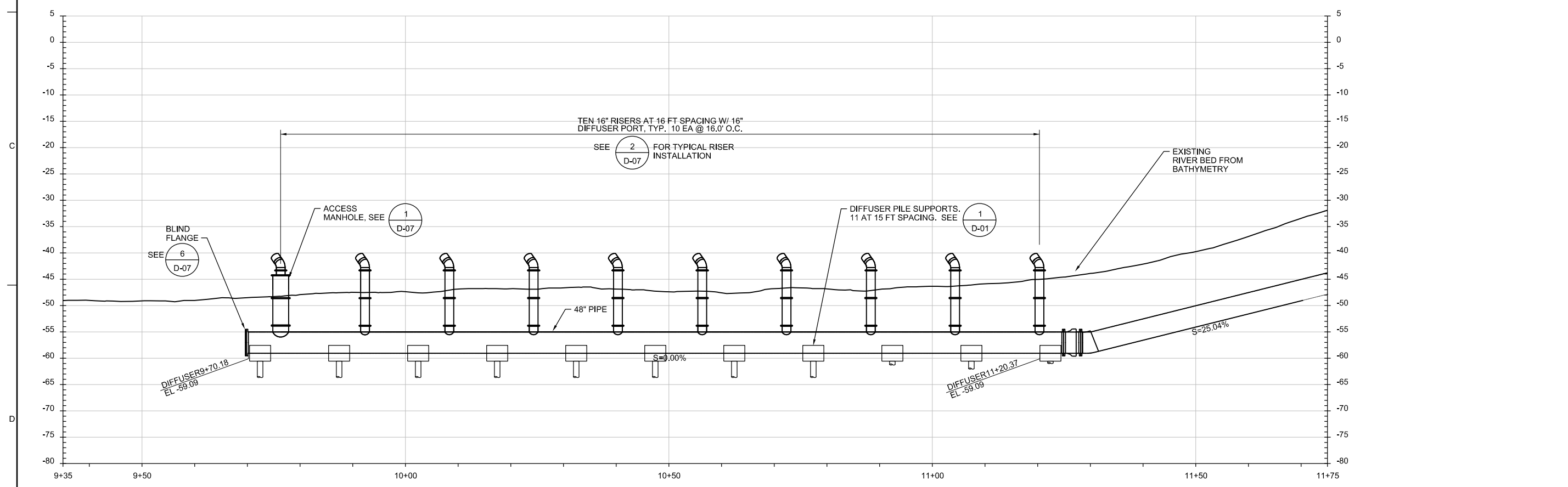
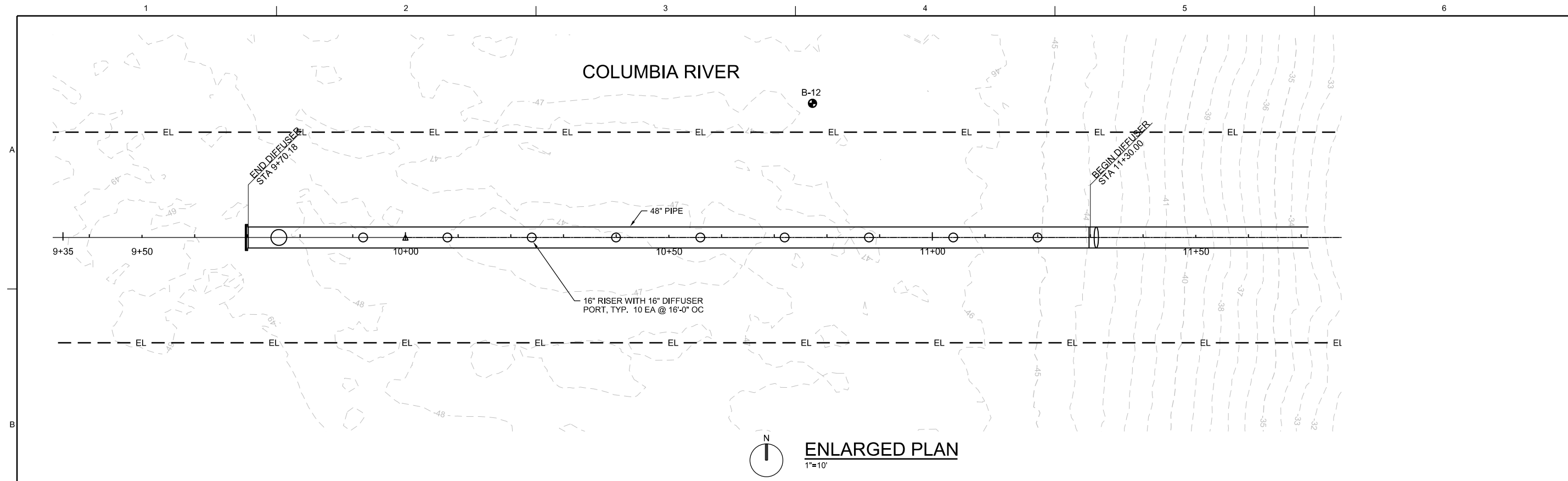
NO.	DATE	DR	REVISION	CHK	APVD	BY	APVD			

Project 92-2016-0023
 Columbia River Outfall and Effluent Pipeline Project
 Discovery Clean Water Alliance
 Clark County, Washington

ch2m
 DETAILS
**CONSTRUCTION AREA AND
 ACCESS ROADS**

1" = X'	
VERIFY SCALE	
BAR IS ONE INCH ON ORIGINAL DRAWING.	
DATE	FEBRUARY 2018
PROJ	663264
DWG	D-05
SHEET	18 of 26

30% DESIGN SUBMITTAL



PROFILE
1"=10'

NO.	DATE	DR	CHK	APVD	BY	APVD
		D. WILSON	D. SUNSERI	Q. COTTEN	R. BEIELER	

Project 92-2016-0023
Columbia River Outfall and Effluent Pipeline Project
Discovery Clean Water Alliance
Clark County, Washington

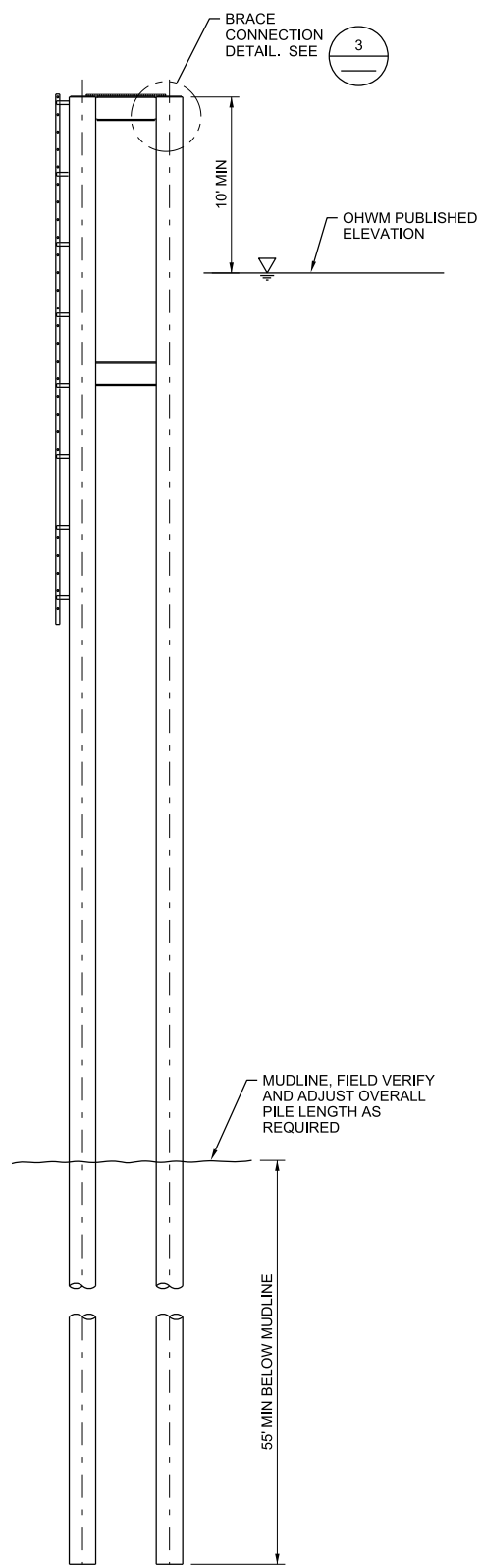
ch2m
DETAILS
DIFFUSER
ENLARGED PLAN & PROFILE

1" = X'	
VERIFY SCALE	
BAR IS ONE INCH ON ORIGINAL DRAWING.	
DATE	FEBRUARY 2018
PROJ	663264
DWG	D-06
SHEET	19 of 26

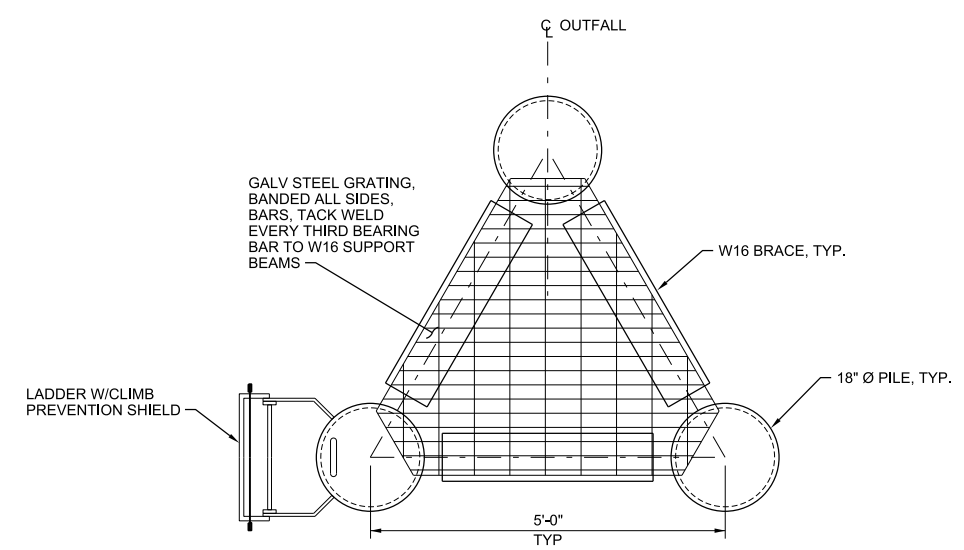
30% DESIGN SUBMITTAL

REUSE OF DOCUMENTS: THIS DOCUMENT, AND THE IDEAS AND DESIGNS INCORPORATED HEREIN, AS AN INSTRUMENT OF PROFESSIONAL SERVICE, IS THE PROPERTY OF CH2M HILL AND IS NOT TO BE USED, IN WHOLE OR IN PART, FOR ANY OTHER PROJECT WITHOUT THE WRITTEN AUTHORIZATION OF CH2M HILL. ©CH2M HILL 2018. ALL RIGHTS RESERVED.

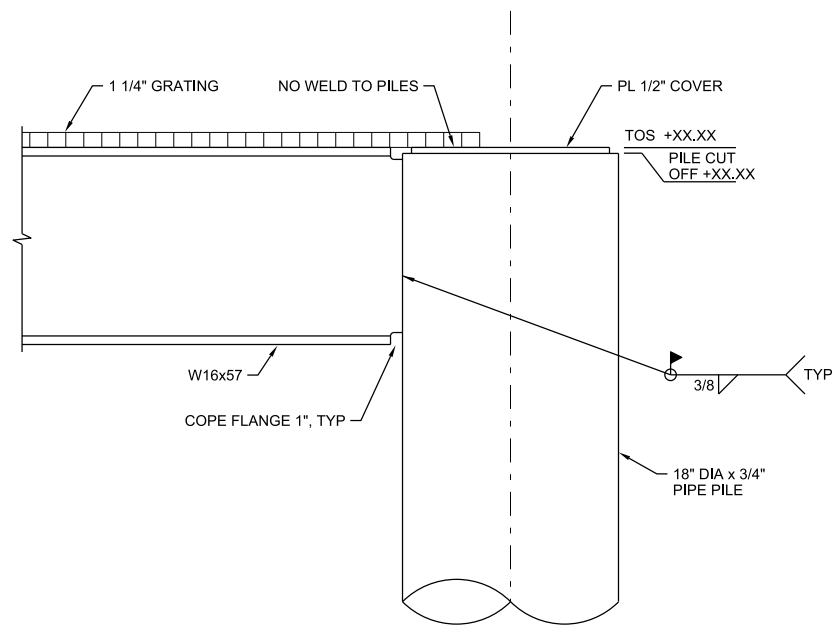
A
B
C
D



2 NAVIGATION MARKER PROFILE
NTS
P-01



1 NAVIGATION MARKER PLAN
3/4"=1'-0"



3 CROSS-BRACE CONNECTION DETAIL
1 1/2"=1'-0"

NO.	DATE	DR	CHK	APVD	BY	APVD
		B. THOMPSON	D. SUNSERI	Q. COTTEN	R. BEIELER	

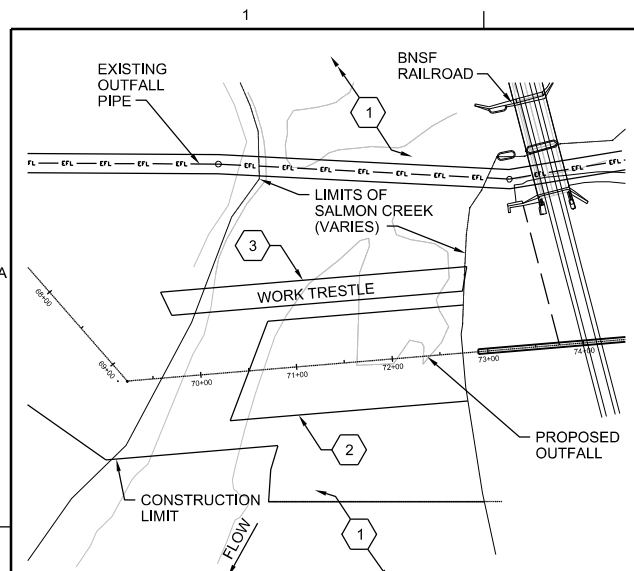
Project 92-2016-0023
Columbia River Outfall and Effluent Pipeline Project
Discovery Clean Water Alliance
Clerk County, Washington

ch2m
DETAILS
OUTFALL NAVIGATION MARKER

DATE	FEBRUARY 2018
PROJ	663264
DWG	D-08
SHEET	21 of 26

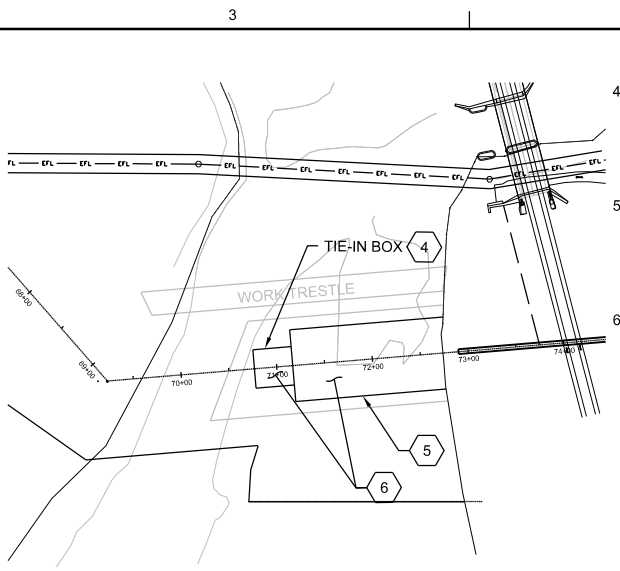
30% DESIGN SUBMITTAL

REUSE OF DOCUMENTS: THIS DOCUMENT, AND THE IDEAS AND DESIGNS INCORPORATED HEREIN, AS AN INSTRUMENT OF PROFESSIONAL SERVICE, IS THE PROPERTY OF CH2M HILL AND IS NOT TO BE USED, IN WHOLE OR IN PART, FOR ANY OTHER PROJECT WITHOUT THE WRITTEN AUTHORIZATION OF CH2M HILL. © CH2M HILL 2018. ALL RIGHTS RESERVED.



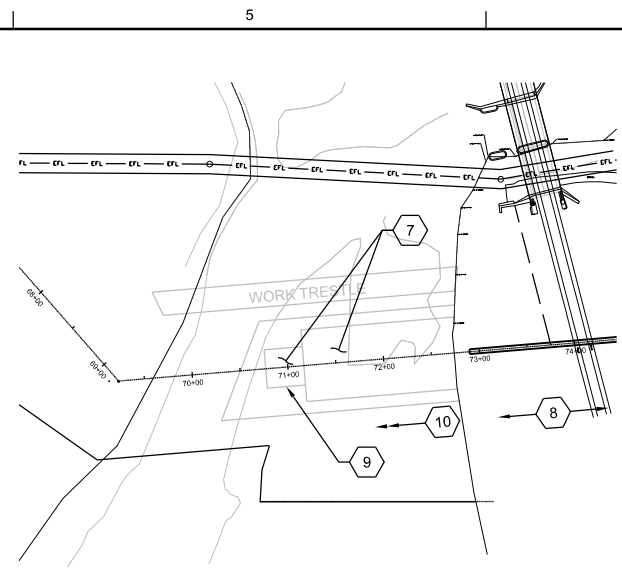
1. INSTALL SIGNS AND MARKER BUOYS ON SALMON CREEK. SURVEY AND SET-OUT CONSTRUCTION LIMITS. ESTABLISH SURVEY CONTROL.
2. CONDUCT FISH EXCLUSION PROCEDURES AND INSTALL FLOATING SILT CURTAIN - EASTERN PORTION OF CREEK.
3. INSTALL CONTRACTOR DESIGNED TEMPORARY WORK TRESTLE. USE NOISE MITIGATION CURTAIN SURROUNDING PILES DRIVEN USING IMPACT HAMMERS.

CONSTRUCTION SEQUENCE: STEP 1
1"=100'



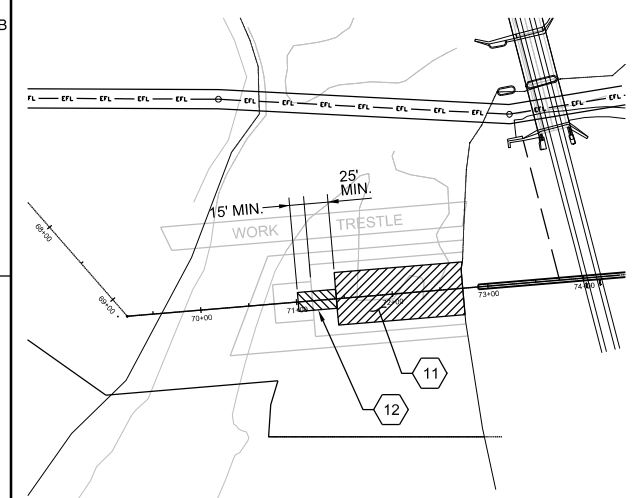
4. CONSTRUCT CENTER TIE-IN BOX USING PRE-CAST CONCRETE BOX WITH KNOCKOUTS OR SHEET PILES WITH WATER TIGHT JOINTS.
5. CONSTRUCT SHEET PILE COFFERDAM ON EASTERN PORTION OF CREEK. CONNECT SHEET PILE TO TIE-IN BOX AND THEN DRIVE SHEETS TOWARD SHORE.
6. CONDUCT FISH SALVAGE.

CONSTRUCTION SEQUENCE: STEP 2
1"=100'



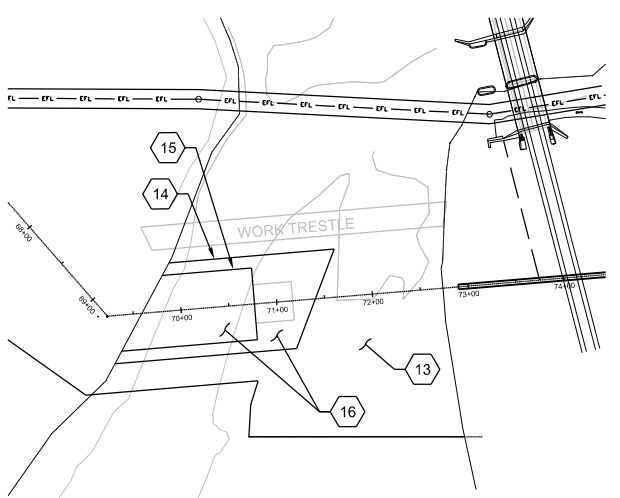
7. EXCAVATE TRENCH IN THE WET. SIDE DIG TRENCH FROM WORK TRESTLE. STOCKPILE PORTION OF SPOILS FOR TRENCH BACKFILL MATERIAL. DISPOSE OF EXCESS SPOIL OFFSITE OR IN SPOIL DISPOSAL AREAS. SURVEY TRENCH TO CONFIRM DEPTH.
8. STRING AND WELD PIPELINE SEGMENT ON LAND. COMPLETE TESTING OF WELDS AND APPLY CORROSION COATING IF REQUIRED.
9. CUT WINDOW IN WEST FACE OF TIE-IN BOX
10. UTILIZE SIDEBOOMS TO FLOAT PIPELINE INTO PLACE. SINK PIPELINE. THREAD END THROUGH WINDOW IN TIE-IN BOX.

CONSTRUCTION SEQUENCE: STEP 3
1"=100'



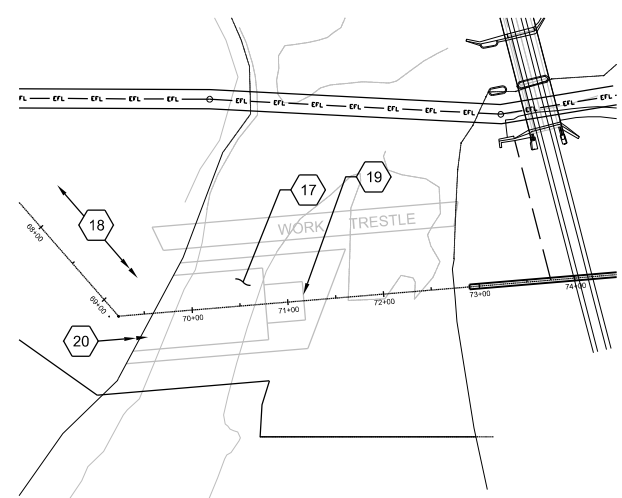
11. BACKFILL PIPELINE. SEE DETAIL A ON SHEET D-01.
12. BACKFILL PIPELINE USING GROUT OR CONTROLLED DENSITY FILL TO SEAL AROUND PIPE PENETRATION INTO TIE-IN BOX. SEE DETAIL D ON SHEET D-01.

CONSTRUCTION SEQUENCE: STEP 4
1"=100'



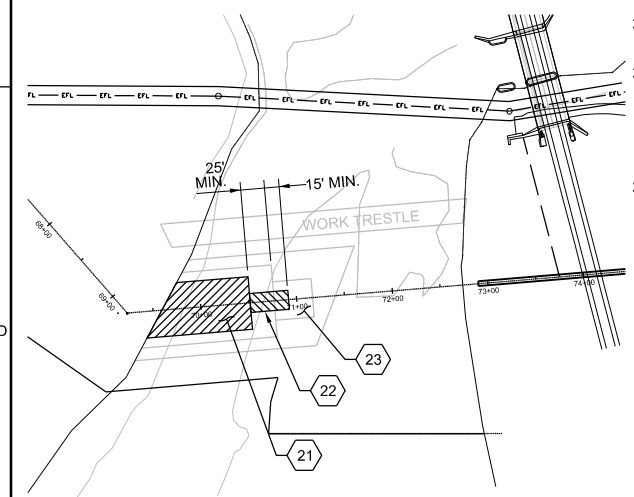
13. REMOVE SHEET PILE COFFERDAM ON EASTERN PORTION OF CREEK.
14. REPOSITION SILT CURTAIN - WESTERN PORTION OF CREEK.
15. CONSTRUCT WESTERN PORTION OF SHEET PILE COFFERDAM. BEGIN AT TIE-IN BOX AND WORK TOWARD SHORE.
16. CONDUCT FISH SALVAGE OPERATIONS.

CONSTRUCTION SEQUENCE: STEP 5
1"=100'



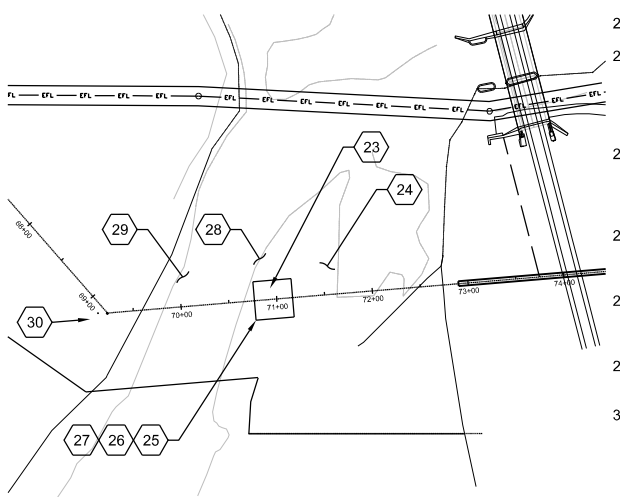
17. EXCAVATE TRENCH IN THE WET. SIDE DIG TRENCH FROM WORKING TRESTLE. STOCKPILE PORTION OF SPOILS FOR TRENCH BACKFILL MATERIAL. DISPOSE OF EXCESS SPOIL OFFSITE OR IN SPOIL DISPOSAL AREAS. SURVEY TRENCH TO CONFIRM DEPTH.
18. STRING AND WELD PIPELINE SEGMENT ON LAND. COMPLETE TESTING OF WELDS AND APPLY CORROSION COATING IF REQUIRED.
19. CUT WINDOW IN WEST FACE OF TIE-IN BOX.
20. FLOAT PIPELINE INTO PLACE. SINK PIPELINE. THREAD THROUGH WINDOW IN TIE-IN BOX.

CONSTRUCTION SEQUENCE: STEP 6
1"=100'



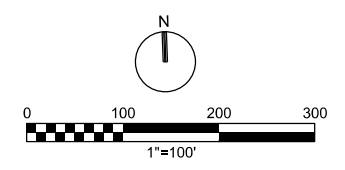
21. BACKFILL PIPELINE. SEE DETAIL A ON SHEET D-01.
22. BACKFILL PIPELINE USING GROUT OR CONTROLLED DENSITY FILL TO SEAL AROUND PIPE PENETRATION INTO TIE-IN BOX. SEE DETAIL D ON SHEET D-01.
23. PUMP DOWN WATER IN TIE-IN BOX. MAKE ONE CONNECTION WELD TO JOIN PIPE SEGMENTS.

CONSTRUCTION SEQUENCE: STEP 7
1"=100'



24. REMOVE SHEET PILE COFFERDAM.
25. IF TIE-IN BOX IS CONSTRUCTED OF SHEET PILES, CUTOFF SHEET PILE ABOVE PIPE WINDOW ON BOTH EAST AND WEST FACE OF TIE-IN BOX USING DIVERS.
26. BACKFILL ABOVE GROUT OR CDF USING NATIVE SOIL TO RE-ESTABLISH CREEK BOTTOM WITHIN TIE-IN BOX.
27. REMOVE REMAINDER OF TIE-IN BOX. PORTION OF TIE-IN BOX BELOW PIPELINE REMAINS IN PLACE.
28. REMOVE TEMPORARY WORKING TRESTLE STARTING AT THE EAST END AND MOVING TO THE WEST.
29. REMOVE FLOATING SILT CURTAIN TO OPEN STREAM.
30. COMPLETE STREAM-BANK RESTORATIONS.

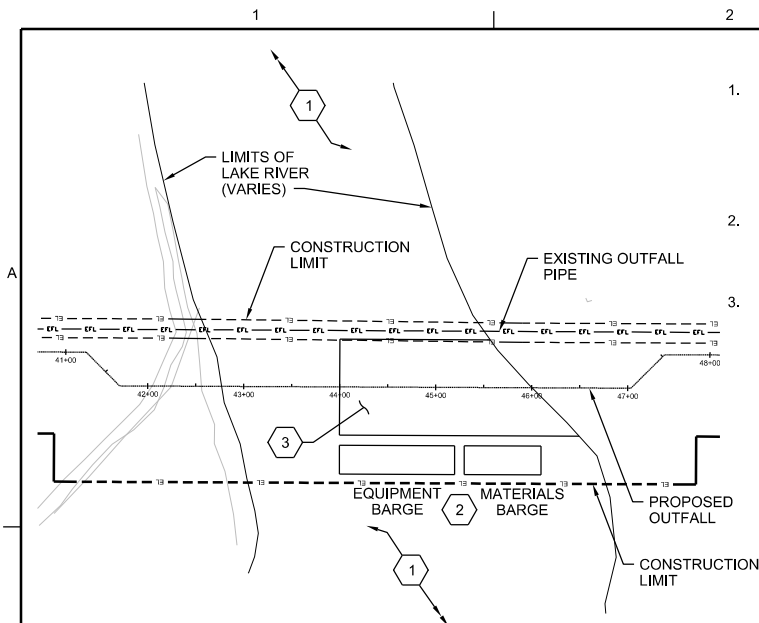
CONSTRUCTION SEQUENCE: STEP 8
1"=100'



NOTE:
THE CONSTRUCTION APPROACH AND SEQUENCE SHOWN DEPICT ONE POTENTIAL METHOD THAT COULD BE UTILIZED BY A CONTRACTOR TO CONSTRUCT THE OUTFALL PIPELINE CROSSING OF SALMON CREEK. THERE ARE OTHER METHODS AND APPROACHES THAT MAY BE USED. THE CONTRACTOR IS RESPONSIBLE FOR DEVELOPING AN APPROACH APPROPRIATE FOR THEIR OWN EQUIPMENT AND CAPABILITIES AND THAT IS IN ACCORDANCE WITH AGENCY PERMIT REQUIREMENTS AND LIMITATIONS.

ch2m CIVIL		POTENTIAL CONSTRUCTION SEQUENCE FOR SALMON CREEK CROSSING	
Project 92-2016-0023 Columbia River Outfall and Effluent Pipeline Project Discovery Clean Water Alliance Clark County, Washington		30% DESIGN SUBMITTAL	
VERIFY SCALE BAR IS ONE INCH ON ORIGINAL DRAWING. 0 1" = 100'			
DATE	FEBRUARY 2018	PROJ	663264
DWG	D-09	SHEET	22 of 26
T. COTTEN DR		T. LANEY CHK	
NO. DATE		REVISION	
BY		APVD	

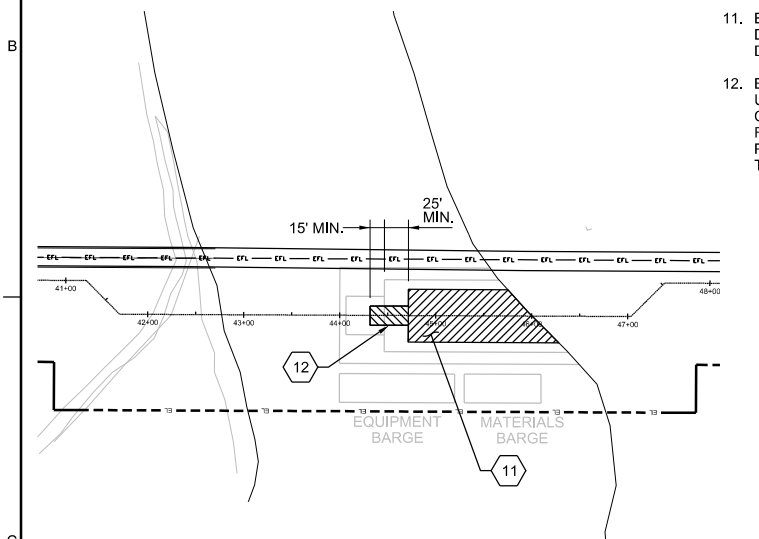
REUSE OF DOCUMENTS: THIS DOCUMENT AND THE IDEAS AND DESIGNS INCORPORATED HEREIN, AS AN INSTRUMENT OF PROFESSIONAL SERVICE, IS THE PROPERTY OF CH2M HILL AND IS NOT TO BE USED, IN WHOLE OR IN PART, FOR ANY OTHER PROJECT WITHOUT THE WRITTEN AUTHORIZATION OF CH2M HILL.
© CH2M HILL 2018. ALL RIGHTS RESERVED.



1. INSTALL SIGNS AND MARKER BUOYS ON LAKE RIVER. SURVEY AND SET-OUT CONSTRUCTION LIMITS. ESTABLISH SURVEY CONTROL.
2. FLOAT EQUIPMENT BARGE AND MATERIALS BARGE INTO PLACE SOUTH OF WORK AREA.
3. CONDUCT FISH EXCLUSION PROCEDURES AND INSTALL FLOATING SILT CURTAIN - EASTERN PORTION OF RIVER.

CONSTRUCTION SEQUENCE: STEP 1

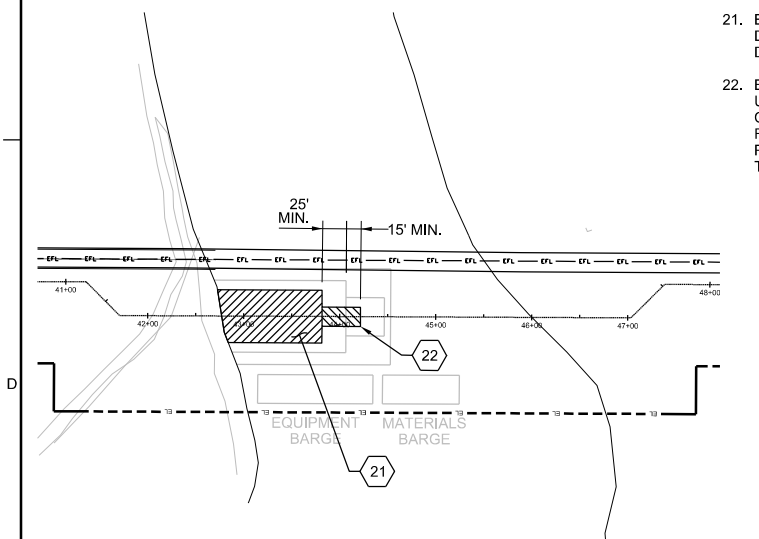
1"=100'



11. BACKFILL PIPELINE. SEE DETAIL A ON SHEET D-01.
12. BACKFILL PIPELINE USING GROUT OR CONTROLLED DENSITY FILL TO SEAL AROUND PIPE PENETRATION INTO TIE-IN BOX.

CONSTRUCTION SEQUENCE: STEP 4

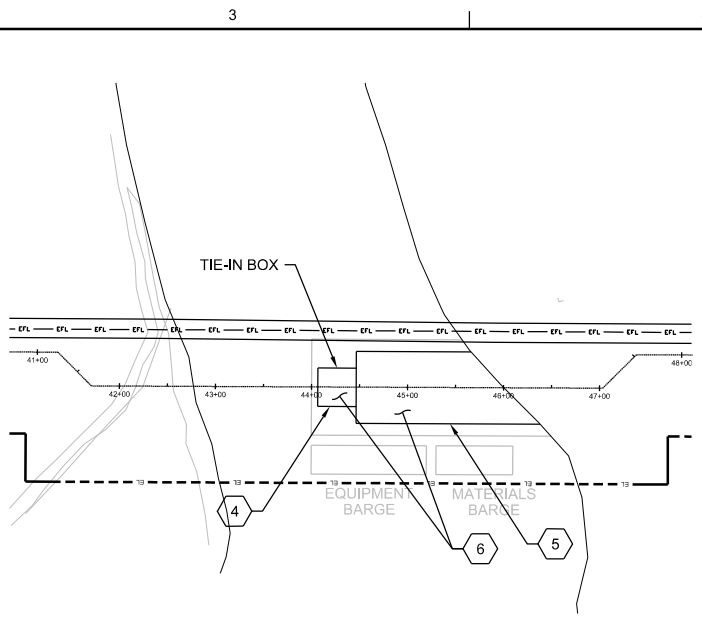
1"=100'



21. BACKFILL PIPELINE. SEE DETAIL A ON SHEET D-01.
22. BACKFILL PIPELINE USING GROUT OR CONTROLLED DENSITY FILL TO SEAL END OF PIPE PENETRATION INTO TIE-IN BOX.

CONSTRUCTION SEQUENCE: STEP 7

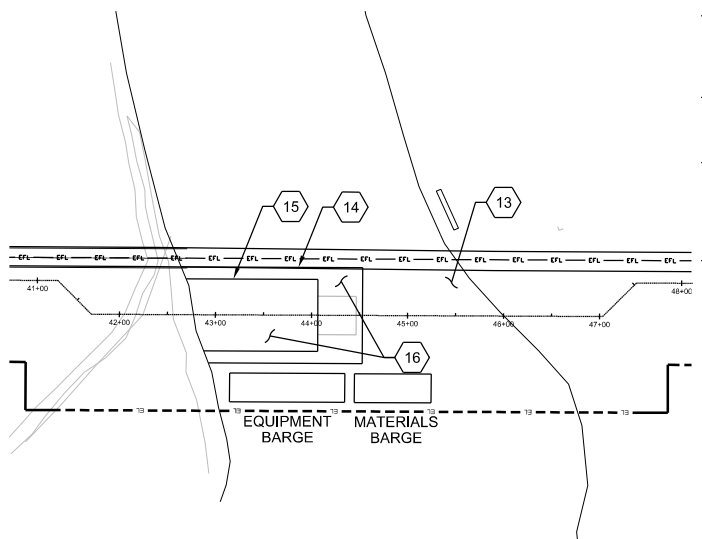
1"=100'



4. CONSTRUCT CENTER TIE-IN BOX USING PRE-CAST CONCRETE BOX WITH KNOCKOUTS OR SHEET PILES WITH WATER TIGHT JOINTS.
5. CONSTRUCT SHEET PILE COFFERDAM ON EASTERN PORTION OF RIVER. CONNECT SHEET PILE TO TIE-IN BOX AND THEN DRIVE SHEETS TOWARD SHORE.
6. CONDUCT FISH SALVAGE

CONSTRUCTION SEQUENCE: STEP 2

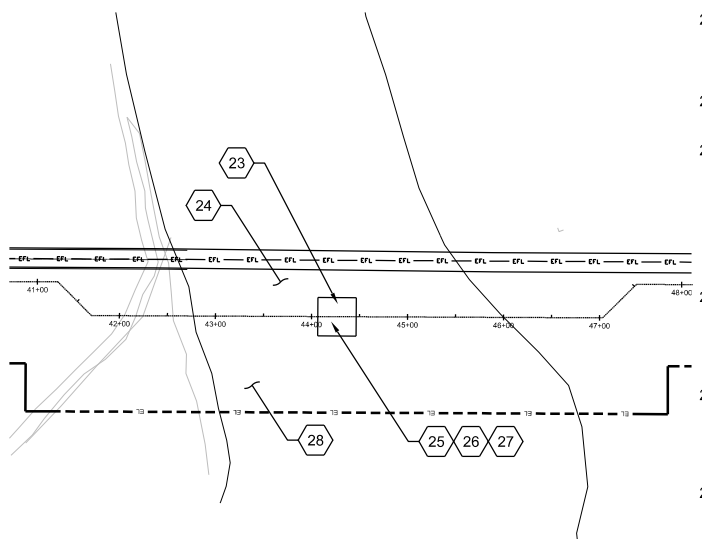
1"=100'



13. REMOVE SHEETPILE COFFERDAM ON EASTERN PORTION OF RIVER.
14. REPOSITION SILT CURTAIN - WESTERN PORTION OF RIVER
15. CONSTRUCT WESTERN PORTION OF SHEETPILE COFFERDAM. BEGIN AT "TIE-IN" BOX AND WORK WEST.
16. CONDUCT FISH SALVAGE

CONSTRUCTION SEQUENCE: STEP 5

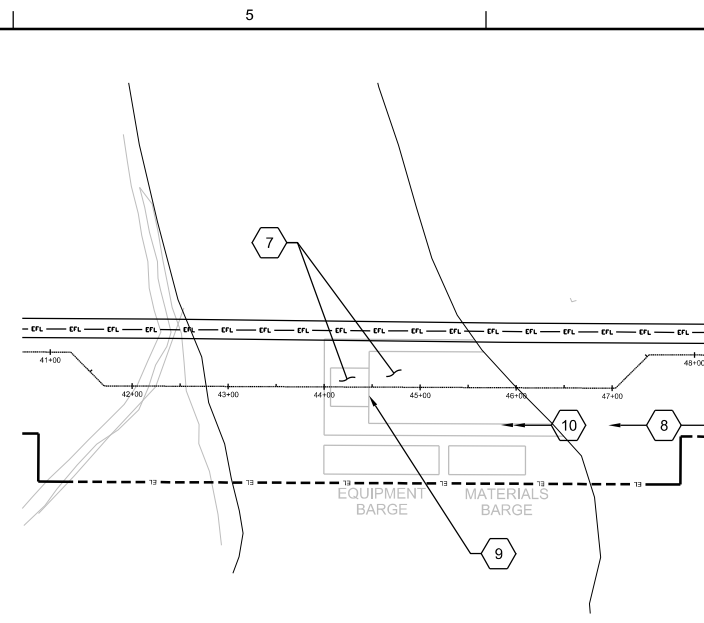
1"=100'



23. PUMP DOWN WATER IN TIE-IN BOX. MAKE WELD TO CONNECT TWO PIPE SEGMENTS.
24. REMOVE SHEETPILE COFFERDAM.
25. IF TIE-IN BOX IS CONSTRUCTED OF SHEET PILES, CUTOFF SHEET PILE ABOVE PIPE WINDOW ON BOTH EAST AND WEST FACE OF TIE-IN BOX USING DIVERS.
26. BACKFILL ABOVE GROUT OR CDF USING NATIVE SOIL TO RE-ESTABLISH RIVER BOTTOM WITHIN TIE-IN BOX.
27. REMOVE REMAINDER OF TIE-IN BOX. PORTION OF TIE-IN BOX BELOW PIPELINE REMAINS IN PLACE.
28. CONDUCT STREAM BANK RESTORATION AND REMOVE FLOATING SILT CURTAIN TO OPEN RIVER.

CONSTRUCTION SEQUENCE: STEP 8

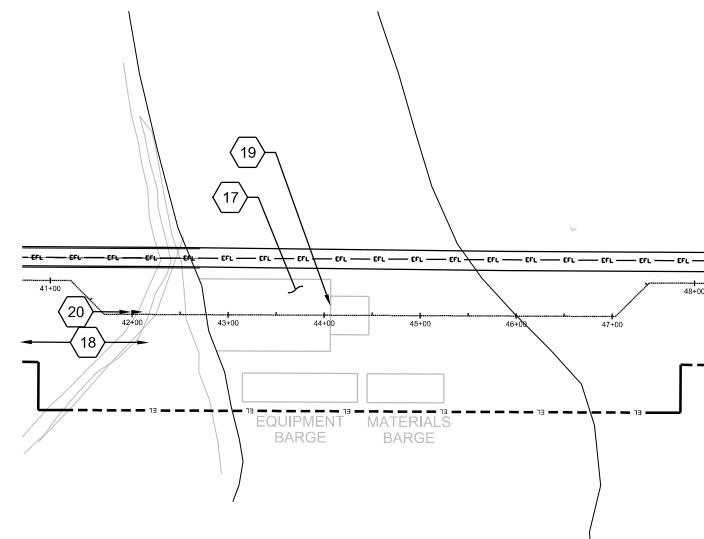
1"=100'



7. EXCAVATE TRENCH 'IN THE WET'. SIDE DIG TRENCH FROM BARGE. STOCKPILE PORTION OF SPOILS FOR TRENCH BACKFILL MATERIAL. DISPOSE OF EXCESS SPOIL OFFSITE OR IN SPOIL DISPOSAL AREAS. SURVEY TRENCH TO CONFIRM DEPTH.
8. STRING AND WELD PIPELINE SEGMENT ON LAND. COMPLETE TESTING OF WELDS AND APPLY CORROSION COATING IF REQUIRED.
9. CUT WINDOW IN WEST FACE OF TIE-IN BOX
10. UTILIZE SIDEBOOMS TO FLOAT PIPELINE INTO PLACE. SINK PIPELINE. THREAD END THROUGH WINDOW IN TIE-IN BOX.

CONSTRUCTION SEQUENCE: STEP 3

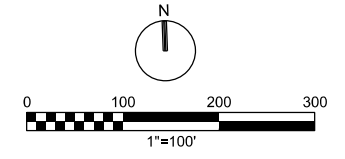
1"=100'



17. EXCAVATE TRENCH IN THE WET. SIDE DIG TRENCH FROM BARGE. STOCKPILE PORTION OF SPOILS FOR TRENCH BACKFILL MATERIAL. DISPOSE OF EXCESS SPOIL OFFSITE OR IN SPOIL DISPOSAL AREAS. SURVEY TRENCH TO CONFIRM DEPTH.
18. STRING AND WELD PIPELINE SEGMENT ON LAND. COMPLETE TESTING OF WELDS AND APPLY CORROSION COATING IF REQUIRED.
19. CUT WINDOW IN WEST FACE OF TIE-IN BOX
20. FLOAT PIPELINE INTO PLACE. SINK PIPELINE. THREAD THROUGH WINDOW IN TIE-IN BOX.

CONSTRUCTION SEQUENCE: STEP 6

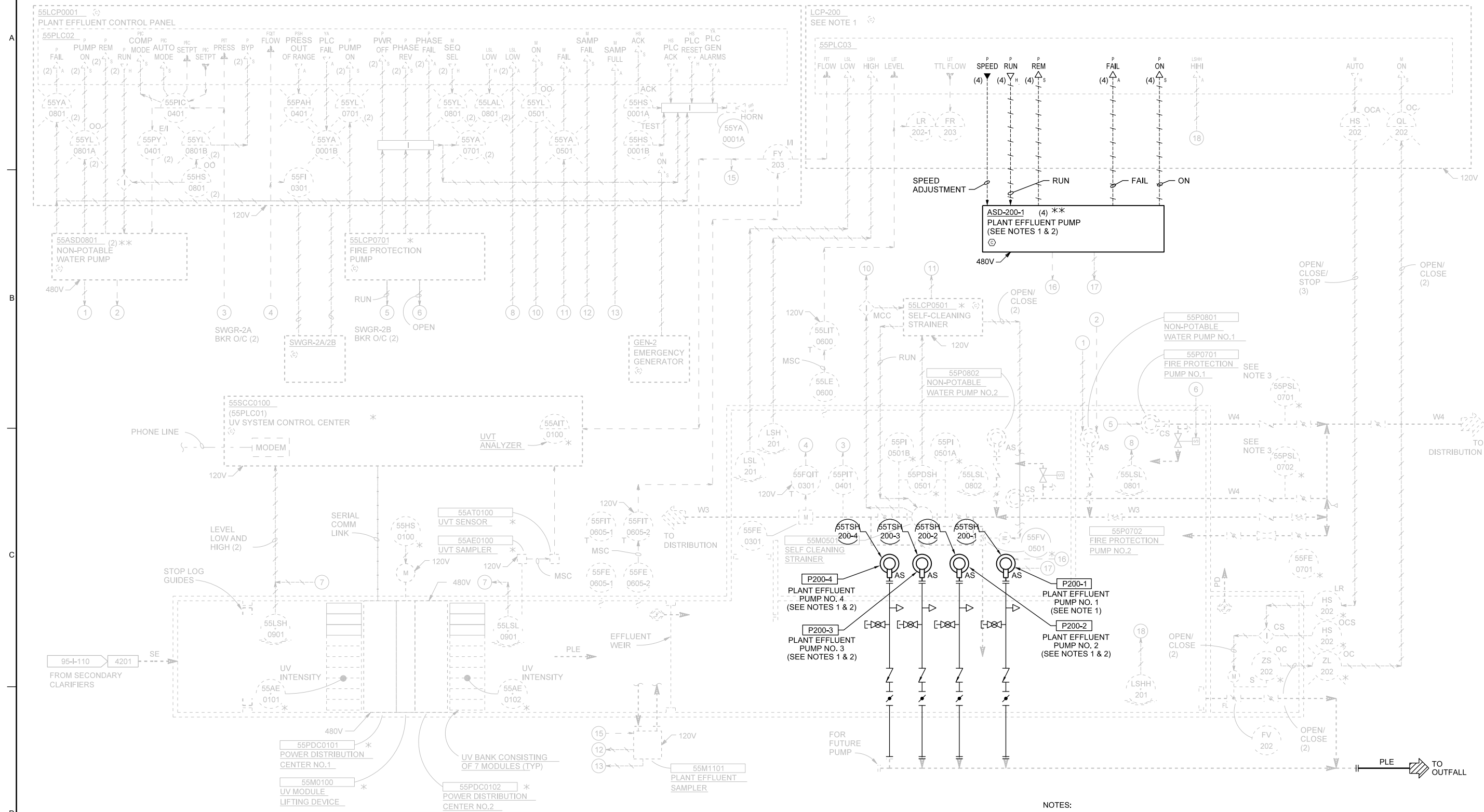
1"=100'



NOTE:
THE CONSTRUCTION APPROACH AND SEQUENCE SHOWN DEPICT ONE POTENTIAL METHOD THAT COULD BE UTILIZED BY A CONTRACTOR TO CONSTRUCT THE OUTFALL PIPELINE CROSSING OF LAKE RIVER. THERE ARE OTHER METHODS AND APPROACHES THAT MAY BE USED. THE CONTRACTOR IS RESPONSIBLE FOR DEVELOPING AN APPROACH APPROPRIATE FOR THEIR OWN EQUIPMENT AND CAPABILITIES AND THAT IS IN ACCORDANCE WITH AGENCY PERMIT REQUIREMENTS AND LIMITATIONS.

NO.		DATE		DR		T. COTTEN	
REVISION		CHK		APVD		Q. COTTEN	
BY		APVD		BY		APVD	
Project 92-2016-0023 Columbia River Outfall and Effluent Pipeline Project Discovery Clean Water Alliance Clark County, Washington							
POTENTIAL CONSTRUCTION SEQUENCE FOR LAKE RIVER CROSSING							
VERIFY SCALE BAR IS ONE INCH ON ORIGINAL DRAWING.							
DATE		FEBRUARY 2018		PROJ		663264	
DWG		D-10		SHEET		23 of 26	

© CH2M HILL 2018. ALL RIGHTS RESERVED.
 THIS DOCUMENT, AND THE IDEAS AND DESIGNS INCORPORATED HEREIN, AS AN INSTRUMENT OF PROFESSIONAL SERVICE, IS THE PROPERTY OF CH2M HILL AND IS NOT TO BE USED, IN WHOLE OR IN PART, FOR ANY OTHER PROJECT WITHOUT THE WRITTEN AUTHORIZATION OF CH2M HILL.
 30% DESIGN SUBMITTAL



- NOTES:**
1. PLANT EFFLUENT PUMPS AND ASSOCIATED ASD ARE NEW 75 HP, 600RPM, 480V, 3 PH.
 2. I/O FOR EFFLUENT PUMPS NO. 2, NO. 3 AND NO. 4 ARE SIMILAR TO EFFLUENT PUMP NO. 1 AS SHOWN.

NO.	DATE	DR	CHK	REVISION	BY	APVD
		J. KRUMSICK	D. SUNSERI			J. KRUMSICK
			D. BRUNKOW			

Project 92-2016-0023
 Columbia River Outfall and Effluent Pipeline Project
 Discovery Clean Water Alliance
 Clark County, Washington

ch2m
 PUMP STATION
P&ID

1" = X'
 VERIFY SCALE
 BAR IS ONE INCH ON ORIGINAL DRAWING.

DATE	FEBRUARY 2018
PROJ	663264
DWG	PS-03
SHEET	26 of 26

30% DESIGN SUBMITTAL

Permitting, Schedule, and Financial Considerations

6.1 Compliance with Applicable Regulatory Requirements

In accordance with RCW Chapter 90.48.110, all engineering reports, plans, and specifications for new construction or improvements to existing sewage treatment systems shall be submitted to and approved by Ecology before construction may begin. RCW Chapter 90.48.110 also allows delegation of this authority to local authorities that meet Ecology's criteria. The District meets Ecology's criteria and has entered into a formal delegation agreement with Ecology. As a result, the District will perform as the delegated authority for certain review and approval responsibilities, as indicated below. The Alliance will serve as SEPA lead agency under their adopted SEPA rules.

The Alliance obtained several regulatory permits and approvals to support field investigations, particularly geotechnical drilling and archaeological survey, during preliminary design. The Alliance obtained a Rivers and Harbors Act Section 10/Clean Water Act Section 404 Nationwide Permit #6 verification for Survey Activities from USACE. In issuing this Nationwide Permit verification, USACE determined there would be no effects on Endangered Species Act-listed species or critical habitat, and that the survey activities would comply with Clean Water Act Section 401, the Magnuson-Stevens Fishery Conservation and Management Act, and the National Historic Preservation Act. Also, the survey activities required a Hydraulic Project Approval from the WDFW and an Aquatic Lands Right of Entry Agreement to drill in riverbeds from DNR. Clark County issued a Shoreline Exemption under WAC 197-11-908 (critical areas), and the Alliance determined that the geotechnical boring was categorically exempt from SEPA review. Finally, a Railroad Crossing Permit was obtained from BNSF.

For the proposed Phase 5A Project, the Alliance will obtain the following permits and approvals:

- Review and approval of the Engineering Report per WAC 173-240-050 and WAC 173-240-060 by Ecology
- Review and approval of final Plans and Specifications per WAC 173-240-020(11) and WAC 173-240-070 by the District
- Review and approval of Construction Quality Assurance Plan per WAC 173-240-020(2) and WAC 173-240-075 by the District
- Modification of NPDES Waste Discharge Permit No. WA0023639 by Ecology
- Clean Water Act Section 401 Water Quality Certification from Ecology
- NPDES Construction Stormwater Discharge Permit from Ecology
- Rivers & Harbors Act Section 10 Permit from USACE
- Clean Water Act Section 404 Permit from USACE
- Bridge Permit from USCG
- Private Aids to Navigation (PATON) notification to USCG
- Permit to place underwater utility and outfall within a navigable water, from the National Ocean Service

- National Historic Preservation Act Section 106 concurrence from USACE/Department of Archaeology and Historic Properties
- Endangered Species Act Incidental Take Permit/Biological Opinion from National Marine Fisheries Service (NMFS)/U.S. Fish and Wildlife Service (USFWS)
- Magnuson-Stevens Fishery Conservation and Management Act consultation with NMFS
- Hydraulic Project Approval from WDFW
- Aquatic Lands Right of Entry Agreement from DNR
- Aquatic Lands Easement from DNR
- Minor Source Air Discharge Permit from SWCAA
- SEPA evaluation by Alliance
- Shoreline Management Act Shoreline Conditional Use Permit from Clark County
- Special Flood Hazard Area Permit from Clark County
- Building Permit from Clark County
- Grading and Drainage Permit from Clark County
- Railroad Crossing Permit from BNSF
- Temporary and permanent easements for crossing private property

Although no specific permit or approval is required, the project will need to comply, minimally, with these regulatory requirements:

- Tribal consultations
- Migratory Bird Treaty Act
- Bald and Golden Eagle Protection Act
- Marine Mammal Protection Act

Project funding will not rely on federal funding, so the project will not have a National Environmental Policy Act documentation requirement, other than that required for federal permitting.

As SEPA lead agency, the Alliance performed the environmental review, prepared the SEPA checklist, determined the potential for environmental impact, distributed the public notice, and issued the Mitigated Determination of Non-Significance. The Alliance cooperated with Clark County on the public notice. The Mitigated Determination of Non-Significance was issued because all the unavoidable environmental impacts can be minimized or mitigated to be insubstantial and/or temporary. The SEPA determination will be provided to Ecology when complete.

6.2 Project Implementation Schedule

The overall Phase 5A Project spans a multi-year period inclusive of planning and preliminary design; permitting and easement acquisition; and final design, bidding, and construction. The Alliance kicked off the project in 2015 and preliminary design continued through the present. The permitting and easement acquisition phase of the project is in progress and will extend through 2019. Final design, bid process, and construction is expected to begin in 2018 and extend through 2022. The project schedule is summarized in Figure 6-1.

Phase	2015	2016	2017	2018	2019	2020	2021	2022
Planning and Preliminary Design								
Permitting and Easements								
Final Design, Bidding, and Construction								

Figure 6-1. Overall Phase 5A Project Schedule
Engineering Report for the Phase 5A Project—Columbia River Outfall and Effluent Pipeline

The project implementation schedule allows for flexibility and contingencies for obtaining regulatory permits and approvals before construction. It is expected that federal and state permits and approvals can be obtained within a 12-month timeframe, and local permits in 3 to 6 months.

The constraints and timelines for construction will be driven by permit terms and conditions, concerns for regulatory compliance, and operability considerations. The major scheduling constraints are as follows:

- In-Water Work—The WDFW recommended in-water work periods (WDFW, 2017) are as follows:
 - Columbia River: August 1 through March 31
 - Lake River: June 1 through October 31
 - Salmon Creek: July 15 through August 15

It is uncertain whether the project can be constructed in one construction season, or will extend over two construction seasons. The work duration will be determined by permitting constraints, weather/water stage, construction method, and the equipment and personnel brought by the contractor. The in-water work period for Salmon Creek is particularly short for constructing cofferdams, temporary work platform, and the effluent pipeline in a single season. It may be possible to negotiate modifications to the recommended work windows because the sites are physically close yet the windows vary greatly.

- Navigability—Vessel navigation on the Columbia River, Lake River, and Salmon Creek needs to remain open (passable) year-round, unless the USCG approves short duration closures.
- Flood Hazard Areas—The FEMA-designated floodways on the Columbia River cannot rise during 100-year flood (from temporary or permanent installation of fills or structures). (Lake River and Salmon Creek do not have designated floodways in the project area.) The highest maximum monthly stage of the Columbia River occurs during January and February, and the period of high maximum monthly stages occurs from November through June (USACE, 2014).
- Wet Season and Groundwater—Saturated surface soil and elevated groundwater tables are expected to be greatest/highest during January and February, and elevated from November through June. Construction during July through October will facilitate access, earthwork, and trench dewatering.
- Migratory Birds—The preferred timeframe for vegetation clearing is outside the migratory bird nesting season, which generally ranges from mid-March to mid-August.

6.3 Cost Estimate

A detailed 30 percent construction cost estimate was prepared using the design drawings provided in Section 5. The summary of the cost estimate is provided in Table 6-1, and the detailed cost estimate is

provided in Appendix K. Table 6-2 also provides a preliminary estimate of the total project costs for the proposed project based on the Engineering Report recommendations. The estimate assumes costs for all elements expected to be part of the final design.

The Association for the Advancement of Cost Engineering (AACE) Class 3 engineer’s cost estimate for the SCTP effluent pipeline and outfall project has been developed with specific assumptions. The estimate is based on the following cost factors:

- 0.6 percent for Location Factor for Vancouver, Washington
- 15 percent for subcontractor overhead and profit (concrete, auger bore, and marine construction)
- 7 percent general conditions
- 3 percent mobilization/demobilization
- 10 percent home office overhead
- 5 percent profit
- 1 percent builder’s risk & general liability
- 1.16 percent payment & performance bonds
- 25 percent Contingency
- 3 percent escalation for 2018 cost
- 8.4 percent Washington State sales tax

The level of accuracy is +30 percent/-20 percent according to the AACE classification system. It is based on various cost resources including R.S. Means 2016 Data, CH2M historical data, contractor input, vendor quotes where available, and estimator judgement. The final costs of the project will depend on the actual labor and material costs, competitive market conditions, final project scope, implementation schedule, and other variable factors.

Table 6-1. Summary of Construction Cost Estimate for the Phase 5A Project—Columbia River Outfall and Effluent Pipeline

Engineering Report for the Phase 5A Project—Columbia River Outfall and Effluent Pipeline

Description	Takeoff Quantity	Grand Total Unit Price ^a	Grand Total ^a
Plant Open Cut	392 LF	\$2,262	\$ 886,639
Railroad Crossing (Auger Bore)	512 LF	\$3,244	\$ 1,661,127
Salmon Creek Crossing	340 LF	\$4,156	\$ 1,413,079
Curtis Lake Ranch Crossing	2,350 LF	\$945	\$ 2,220,272
Lake River Crossing	300 LF	\$3,775	\$ 1,132,567
Fazio Property Crossing	2,585 LF	\$1,126	\$ 2,881,690
Outfall Section	1,138 LF	\$3,295	\$ 3,749,939
Miscellaneous Site Work	1 LS	\$453,438	\$ 453,438
Pump Station Improvements	1 LS	\$1,271,341	\$ 1,271,341
Access Road Improvements	1 LS	\$492,456	\$ 492,456
Total Cost to Contractor			\$ 16,162,548
Base Bid ^b (Expected Cost w/Tax)			\$ 17,520,202
Low Bid ^b (-20 percent)			\$ 14,000,000
High Bid ^b (+30 percent)			\$ 22,750,000

^a Includes 25% contingency and other cost factors.

^b Includes 8.4% taxes.

LF = linear feet; LS = lump sum

Table 6-2. Summary of Total Phase 5A Project Cost*Engineering Report for the Phase 5A Project—Columbia River Outfall and Effluent Pipeline*

Item	Cost Estimate
<i>Delivery</i>	
Engineering and Project Management	\$3,400,000
Permitting	\$1,800,000
Construction Management	\$1,800,000
Total Delivery	\$7,000,000
<i>Construction</i>	
Effluent Pipeline and Outfall	\$11,912,965
Effluent Pump Station Improvements	\$1,017,073
Contingency (25%)	\$3,232,510
Taxes (8.4%)	\$1,357,654
Total Construction	\$17,520,202
Total Project Cost	\$24,520,202

6.4 Project Funding

The capital expenditures portion of proposed project will be funded as an Alliance Capital Project. The Alliance Capital Project work is funded by a combination of Regional Service Charges and debt proceeds to fund larger capital projects. The Alliance costs are then allocated to the Alliance Member Agencies, based on the amount of capacity allocation purchased with the project. In this case, the resulting Alliance charges from the Phase 5A Project have been communicated to the City of Battle Ground and Clark Regional Wastewater District as funding partners. The City and the District, in turn, have included the Alliance costs in the respective financial planning and rate modeling efforts to ensure that retail rates and charges are adequate to fund this project.

The current annual O&M budget for SCTP is approximately \$4 million per year. The additional costs for this work will be included in the future budgets associated with the construction period and commencement of operations.

References

- AECOM and U.S. Army Corps of Engineers (USACE). 2011. *Structural and Hydraulic Analysis of Columbia River Pile Dikes - Final Report*. October.
- Archaeological Investigations Northwest, Inc. (AINW). 2017. *Cultural Resource Study: Reconnaissance and Alternatives Analysis; Columbia River Outfall and Effluent Pipeline Project, Clark County, Washington*. AINW, Portland, Oregon. Report No. 3546.
- Baumgartner, D.J., W. Frick, and P. Roberts. 1994. *Dilution Models for Effluent Discharges* (3rd ed.). EPA/600/R-94/086, U.S. Environmental Protection Agency, Pacific Ecosystems Branch, Newport, Oregon.
- BergerABAM. 2015. *Columbia River Outfall and Effluent Pipeline—Phase I Environmental Site Assessment, Tax Parcels 191176000, 183058000, 191067000, 191177000, 986029218, and 986035619*. BergerABAM, Vancouver, Washington. A16.0047.00. November.
- BergerABAM. 2017a. *Wetland and Stream Delineation and Assessment*. BergerABAM, Vancouver, Washington. A16.0047.00. October.
- BergerABAM. 2017b. *City of Battle Ground 2015 General Sewer Plan*. BergerABAM, Vancouver, Washington. A14.0299.02. June.
- BHC. 2016. *Draft Clark Regional Wastewater District Comprehensive General Sewer Plan Update*.
- Brooks, N.H. 1960. "Diffusion of Sewage Effluent in an Ocean Current." In Pearson, E.A. *Proceedings, International Conference on Waste Disposal in the Marine Environment*. Pergammon Press, New York, New York. pp. 246–267.
- Century West Engineering Corporation. 1989. *Geotechnical Exploration for Salmon Creek Wastewater Treatment Plant Expansion*. Century West Engineering, Portland, Oregon.
- Century West Engineering Corporation. 1990. *Subsurface Exploration, Revised Digester Location, Salmon Creek Wastewater Treatment Plant*. Century West Engineering, Portland, Oregon.
- CH2M HILL (CH2M). 1995. *Salmon Creek Wastewater Treatment Plant Expansion Program Final Environmental Impact Statement*. Clark County Department of Public Works, Vancouver, Washington. October.
- CH2M HILL (CH2M). 2004a. *Outfall Dilution Study Report for the Salmon Creek Wastewater Treatment Plant*. Clark County Department of Public Works, Hazel Dell Sewer District, City of Battle Ground, Washington. January.
- CH2M HILL (CH2M). 2004b. *Salmon Creek Wastewater Management System Wastewater Facilities Plan/General Sewer Plan*. Clark County Department of Public Works, Vancouver, Washington.
- CH2M HILL (CH2M). 2005. *Outfall Modification Plan and Engineering Report, Outfall Extension Project*. Prepared for City of St. Helens, Oregon, and Boise White Paper, LLC. CH2M HILL, Portland, Oregon. January.
- CH2M HILL (CH2M). 2006. *Effluent Mixing Study Report for the Westside Water Reclamation Facility, City of Vancouver, Washington*. CH2M HILL, Portland, Oregon. January.
- CH2M HILL (CH2M). 2013. *Salmon Creek Wastewater Management System Wastewater Facilities Plan/General Sewer Plan Amendment*. CH2M HILL, Portland, Oregon.
- CH2M HILL (CH2M). 2015. *Quality Assurance Project Plan for Water Quality Sampling of the Columbia River*. CH2M HILL, Portland, Oregon. July.

- CH2M HILL (CH2M). 2016a. *Columbia River Bedform Analysis for Salmon Creek WWTP – Columbia River Outfall and Effluent Pipeline Project*. CH2M HILL, Portland, Oregon. July.
- CH2M HILL (CH2M) 2016b. *Sampling and Analysis Plan for the Salmon Creek Treatment Plant Outfall Sediment Evaluation*. CH2M HILL, Portland, Oregon. October.
- CH2M HILL (CH2M). 2016c. *Sediment Evaluation of the Salmon Creek Treatment Plant Outfall Site*. CH2M HILL, Portland, Oregon. December.
- CH2M HILL (CH2M). 2017a. *Engineering Report for the Phase 5B Project—Salmon Creek Treatment Plant Improvements*. Phase 5 Expansion Program. An Alliance Capital Project delivered by Clark Regional Wastewater District as Administrative Lead for the Discovery Clean Water Alliance. Prepared for Washington State Department of Ecology. CH2M HILL, Portland, Oregon. October.
- CH2M HILL (CH2M). 2017b. *Columbia River Shoreline Stability Assessment for the Proposed Salmon Creek WWTP Outfall Replacement Project*. CH2M HILL, Portland, Oregon. October.
- CH2M HILL (CH2M). 2017c. *Columbia River Outfall and Effluent Pipeline Project Draft Geotechnical Data Report*. CH2M HILL, Portland, Oregon.
- Clark County, Washington. 2016. *20 Year Comprehensive Growth Management Plan 2015-2035*. Department of Community Planning, Vancouver, Washington.
- Discovery Clean Water Alliance (Alliance). 2018. *Phase 5A Project—Columbia River Outfall and Effluent Pipeline Project SEPA Checklist*. Prepared by CH2M HILL for the Discovery Clean Water Alliance, Vancouver, Washington.
- Doneker, R.L., and G.H. Jirka. 2007. *CORMIX User Manual. A Hydrodynamic Mixing Zone Model and Decision Support System for Pollutant Discharges into Surface Waters*. EPA-823-K-07-001. December.
- Federal Emergency Management Agency (FEMA). 2012. *Flood Insurance Study for Clark County, Washington and Incorporated Areas*. Flood Insurance Study No. 53011CV001V. September.
- Frick, W.E., P.J.W. Roberts, L. R. Davis, J. Keyes, D.J. Baumgartner, and K.P. George. 2003. *Dilution Models for Effluent Discharges, 4th Edition (Visual Plumes)*. Environmental Research Division, NERL, ORD. U.S. Environmental Protection Agency. March 4.
- Muellenhoff, W.P., et al. November 1985. *Initial Mixing Characteristics of Municipal Ocean Discharges. Volume I, Procedures and Applications*. EPA 600/3-85-073a. U.S. Environmental Protection Agency, Office of Research and Development.
- National Marine Fisheries Service (NMFS) and National Oceanic and Atmospheric Administration (NOAA). 2000. *Designated Critical Habitat: Critical Habitat for 19 Evolutionarily Significant Units of Salmon and Steelhead in Washington, Oregon, Idaho, and California*. Final Rule. Federal Register 65(32): 7764-7787. February 16.
- National Oceanic and Atmospheric Administration (NOAA). 2012. Office of Protected Resources. <http://www.nmfs.noaa.gov/pr/species/fish/>. Accessed on January 19, 2012.
- Nobeltec. 2009. Tides and Currents. Jeppesen Marine, Inc., Portland, Oregon.
- Roberts, P.J.W., W.H. Snyder, and D.J. Baumgartner. 1989a. Ocean Outfalls I: Submerged Wastefield Formation. *ASCE Journal of Hydraulic Engineering* 115(1): 1-25.
- Roberts, P.J.W., W.H. Snyder, and D.J. Baumgartner. 1989b. Ocean Outfalls II: Spatial Evolution of Submerged Wastefield. *ASCE Journal of Hydraulic Engineering* 115(1): 26-48.
- Roberts, P.J.W., W.H. Snyder, and D.J. Baumgartner. 1989c. Ocean Outfalls III: Effect of Diffuser Design on Submerged Wastefield. *ASCE Journal of the Hydraulic Engineering* 115(1): 49-70.

- Shirazi, M.A. and L.R. Davis. 1974. *Workbook of Thermal Plume Prediction: Volume 2, Surface Discharge*. EPA-R2-72-005b. May.
- Smith, Renelle, Easement Land Manager/Department of Natural Resources, Aquatic Resources Division, Rivers District. 2017. Personal communication with Quitterie Cotten/CH2M. October.
- StreamNet. 2016. Pacific States Marine Fisheries Commission. <https://www.streamnet.org/>
- U.S. Army Corps of Engineers (USACE). 1973. Lower Columbia River Historic Ordinary High Water Elevations (for determining limits of jurisdiction under Section 10 of the Rivers and Harbors Act). [Based on FLOOD PROFILES (CL-03-116, April 1973 revision)] U.S. Army Corps of Engineers, Portland, Oregon.
- U.S. Army Corps of Engineers (USACE). 2004. *Portland-Vancouver Harbor Information Package*. 2nd ed. Reservoir Regulation and Water Quality Section. November.
- U.S. Army Corps of Engineers (USACE). 2009. *Sediment Evaluation Framework for the Pacific Northwest*. May.
- U.S. Army Corps of Engineers (USACE). 2014. *Portland-Vancouver Harbor Information Package*, Third Edition. U.S. Army Corps of Engineers, Reservoir Regulation and Water Quality Section, Portland, Oregon. October.
- U.S. Environmental Protection Agency (EPA). 1986. *Quality Criteria for Water*. EPA 440/5-86-001. May.
- U.S. Environmental Protection Agency (EPA). 1991. *Technical Support Document for Water Quality-Based Toxics Control*. EPA 505/2-90-001.
- U.S. Environmental Protection Agency (EPA). 2003. *Columbia/Snake Rivers Temperature TMDL, Preliminary Draft*. July. Accessed November 27, 2017. <http://columbiariverkeeper.org/wp-content/uploads/2017/08/17.pdf>
- U.S. Environmental Protection Agency (EPA). 2006. DFLOW 3.1 Model for Flow Statistics. March.
- U.S. Environmental Protection Agency (EPA). 2013. *Aquatic Life Ambient Water Quality Criteria for Ammonia – Freshwater 2013*. August.
- U.S. Environmental Protection Agency (EPA). 2016. *Partial Approval/Partial Disapproval of Washington's Human Health Water Quality Criteria and Implementation Tools*. November.
- U.S. Geological Survey (USGS). 2017. National Water Information System Web database.
- van Rijn, L. 1982. Predictions of Bed Forms and Alluvial Roughness. Paper presented at Euromech 156, Mechanics of Sediment Transport, Technical Faculty of Istanbul, Turkey, July 12–14, 1982. <http://www.leovanrijn-sediment.com/papers/P1-1982b.pdf>
- van Rijn, L. 1984. "Sediment Transport, Part III: Bed Forms and Alluvial Roughness." *J. Hydraul. Eng.* 10.1061/(ASCE)0733-9429(1984)110:12(1733), 1733-1754. <http://www.leovanrijnsediment.com/papers/P1-1984.pdf>
- Washington State Department of Ecology (Ecology). 2011a. *Development of Benthic SQVs for Freshwater Sediments in Washington, Oregon, and Idaho*.
- Washington State Department of Ecology (Ecology). 2011b. *Water Quality Program Guidance Manual: Supplemental Guidance on Implementing Tier II Antidegradation*. Publication No. 11-10-073. September.
- Washington State Department of Ecology (Ecology). 2015a. *Water Quality Program Permit Writer's Manual*. Publication No. 92-109. Revised January.
- Washington State Department of Ecology (Ecology). 2015b. *Sediment Cleanup Users Manual II (SCUM)*.

SECTION 7 – REFERENCES

Washington State Department of Fish and Wildlife (WDFW). 2017. *Times when Spawning or Incubating Salmonids Are Least Likely to Be Within Washington State Freshwaters*. Olympia, Washington. September.